

# INSTALLATION & OPERATION MANUAL

EXTERIOR CODE 3® TORUS™  
MODULES



**3-LED**



**6-LED**

Code 3,® Inc., a subsidiary of  
Public Safety Equipment, Inc.



## TORUS™ EXTERNAL MODULES

### Contents:

Introduction.....	3
Features and Specifications.....	3
Installation.....	4
Wiring.....	5
Programming.....	5-6
Maintenance.....	7
Warranty.....	8

**IMPORTANT:**

*Read all instructions and warnings before installing and using.*

**INSTALLER:** *This manual must be delivered to the end user of this equipment.*



This Product contains high intensity LED devices. To prevent eye damage, DO NOT stare into light beam at close range.



The use of this or any warning device does not insure that all drivers can or will observe or react to an emergency warning signal. Never take the right-of-way for granted. It is your responsibility to be sure you can proceed safely before entering an intersection, driving against traffic, responding at a high rate of speed, or walking on or around traffic lanes.

The effectiveness of this warning device is highly dependent upon correct mounting and wiring. Read and follow the manufacturer's instructions before installing or using this device. The vehicle operator should insure daily that all features of the device operate correctly. In use, the vehicle operator should insure the projection of the warning signal is not blocked by vehicle components (i.e.: open trunks or compartment doors), people, vehicles, or other obstructions. This equipment is intended for use by authorized personnel only. It is the user's responsibility to understand and obey all laws regarding emergency warning devices. The user should check all applicable city, state and federal laws and regulations. Code 3, Inc., assumes no liability for any loss resulting from the use of this warning device. Proper installation is vital to the performance of this warning device and the safe operation of the emergency vehicle. It is important to recognize that the operator of the emergency vehicle is under psychological and physiological stress caused by the emergency situation. The warning device should be installed in such a manner as to: A) Not reduce the output performance of the system, B) Place the controls within convenient reach of the operator so that he can operate the system without losing eye contact with the roadway.

Emergency warning devices often require high electrical voltages and/or currents. Properly protect and use caution around live electrical connections. Grounding or shorting of electrical connections can cause high current arcing, which can cause personal injury and/or severe vehicle damage, including fire.

**PROPER INSTALLATION COMBINED WITH OPERATOR TRAINING IN THE PROPER USE OF EMERGENCY WARNING DEVICES IS ESSENTIAL TO INSURE THE SAFETY OF EMERGENCY PERSONNEL AND THE PUBLIC.**

## Introduction:

The TORUS™-EX LED modules are weatherproof LED based warning light modules that contain state-of-the-art high intensity LEDs. These products provide multiple operation modes including a steady-burn mode. These products may be adapted to a variety of exterior applications such as motorcycle applications, OEM fire truck, grill light and back-deck applications.

## Features and Specifications:

**Operating Voltage:** 10-16Vdc Reverse Polarity Protection.

**Flashing Current Draw:**

Red/Amber:	
Single	- .25A Avg.
Dual	- .5A Avg.
Blue/White:	
Single	- .4A Avg.
Dual	- .8A Avg.

**Steady Burn Current Draw:**

Red/Amber:	
Single	- .5A Avg.
Dual	- 1.0A Avg.
Blue/White:	
Single	- .8A Avg.
Dual	- 1.6A Avg.

**Available colors** - Red, Amber, White or Blue or any combination for dual modules.

**Available configurations** - 3 or 6 LED modules, Black or Chrome bezels. Directional, wide, hybrid (combination of directional and wide individual optics) and vertical optics.

## Options:

**The TORUS-EX is available in two basic models:**

**6-LED**-A unit with 6 LEDs and TORUS units. The 6 LEDs are operated in two sets of three LEDs. This allows dual color units as well as the ability to wig-wag the flash patterns. One side can be steady burned while the other side will flash as well. Directional, wide, hybrid and vertical hybrid optics are available. An option is available to allow each side to be controlled independently. In this option, the 6-LED unit is essentially two 3-LED units combined in a single housing. Review the instructions for the 3-LED module to wire these units.

**3-LED** The 3 LED model will be a single color and is available in directional, wide, hybrid or vertical hybrid optics. Multiple flash patterns are available, along with the ability of the units to communicate with other 3 LED model units.

## Installation:

This unit can be mounted to metal surfaces using two #8 x 1/2 pan head sheet metal screws (included). This unit can also be mounted to plastic surfaces using two #8 x 1/2 pan head machine screws (included). The cable routing hole (3/8" minimum diameter) can be drilled to match the wire exit. An optional rubber gasket, included with the unit, may be used

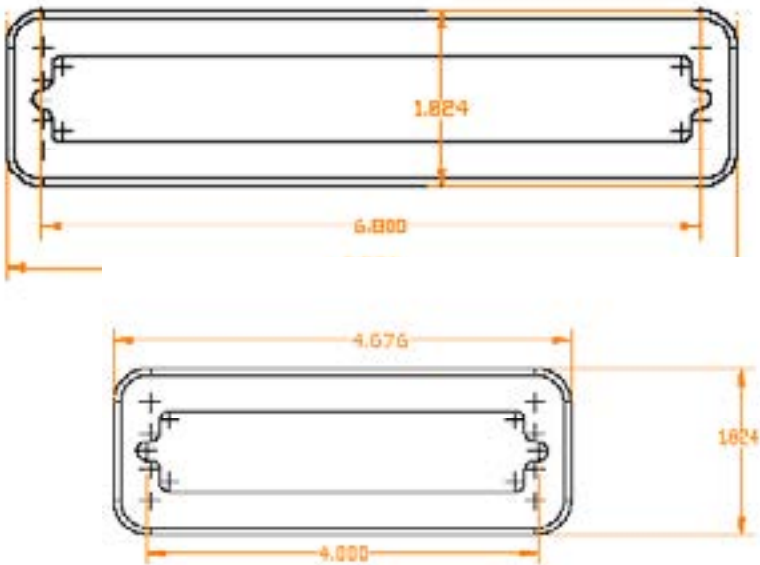

If the product is to be used inside the vehicle, it may cause severe personal injury if not properly mounted and secured. Objects used in vehicle may become airborne during a collision or other sudden changes in vehicle speed or direction, such as braking, acceleration or turns.

## 3-LED Operation

The 3-LED model can communicate with other 3-LED units via a PARENT / CHILD relationship as described in the following sections.

### Wiring

The Black wire is the Ground wire and the Red wire is the Power (+) wire. The White wire is used for flash pattern selection and it is also used to set the PARENT or CHILD mode. The Grey wire is used for communications between the PARENT and CHILD. Attach the Grey wire of the PARENT to the Grey wire of any other head (s) set in CHILD mode to coordinate Alternating or Simultaneous flash patterns between heads.

## Setting Parent / Child Mode

All units shipped will be in the PARENT mode with the factory default, Cycleflash pattern. To change a head to the CHILD mode hold the White wire to Ground for 5 seconds or more. When in the CHILD mode the head will need the Grey communications wire connected the PARENT Grey wire to enable flashing, unless in Steady Burn. Alternatively, the Grey communications wire of a CHILD can be connected to +12V to enable flashing during set-up. If communications is lost between the PARENT/CHILD for over 15 seconds the CHILD head will independently flash until the communications is restored. A head set to the CHILD mode can be reset to a PARENT again by holding the White wire to Ground for 5 seconds or longer.

## Setting Flash Patterns

To change the flash pattern of any PARENT or CHILD hold the White wire to Ground for at least 1 second, and less than 3 seconds, and then release. While holding the White wire to Ground the head will stop flashing until released. Remember that the Grey wire of a CHILD must be connected to the Grey wire of a PARENT, or to +12V, to enable flashing.

When setting flash patterns, the CHILD will require selecting between Alternating or Simultaneous patterns, while the PARENT will only require selecting the pattern desired. The tables below show the available flash options and their selection order for each mode. Simultaneous and Alternating flash patterns are exactly the same flash patterns but will either alternate or flash simultaneously when connected to a PARENT. Heads will come from the factory preset to the PARENT mode with the default Cycleflash pattern. When changing a factory preset PARENT head to a CHILD the head will default to the Alternating Cycleflash pattern, position 1, as shown in the table below:

Flash Pattern	Description
1	Alternating Cycleflash ( Factory default)
2	Alternating Quadflash
3	Alternating Doubleflash
4	Alternating Singleflash
5	Simultaneous Cycleflash
6	Simultaneous Quadflash
7	Simultaneous Doubleflash
9	Simultaneous Singleflash
10	Steady Burn

## 3-LED Flash Options Available in PARENT Mode

Flash Pattern	Description
1	Cycleflash (Factory default)
2	Quadflash
3	Doubleflash
4	Singleflash
5	Steady Burn

Note: When using the Cycleflash pattern, all heads must be in Cycleflash. All flash patterns are 70 fpm.

### **3-LED Communications Set-up and Connections**

With the Grey wires connected between the PARENT and one or more heads set to CHILD mode, all CHILD heads will either flash Alternately with the PARENT head or Simultaneously with the PARENT head depending on the flash pattern selected. The following example shows how to set-up a basic system with one PARENT head and three CHILD heads. For this example two CHILD heads will flash Alternately with the PARENT head and one CHILD head will flash Simultaneously with the PARENT head. All heads will be in the Cycleflash pattern.

#### **Step 1**

One head will need to be selected to be in the PARENT mode. As mentioned above, the heads are shipped in PARENT mode in the factory default, Cycleflash pattern. Select the desired head to be the PARENT head. Power the head to verify that it is in Cycleflash.

#### **Step 2**

Select one head to be the Simultaneous CHILD. Power the heads and set this head to CHILD mode by holding the White wire to Ground for 5 seconds or longer. If desired, you can test that it is actually in the CHILD mode by temporarily disconnecting the GREY wire. The head should stop flashing until reconnected. The head will now be in CHILD mode in the Alternating Cycleflash pattern.

#### **Step 3**

Set the flash pattern of the Simultaneous Child to Simultaneous Cycleflash. This can be done by momentarily touching the White wire to Ground and releasing until the Simultaneous Cycleflash pattern is reached. To go from the factory default pattern of Alternating Cycleflash to the Simultaneous Cycleflash pattern you will need to step from pattern 1 ( Alternating Cycleflash) to pattern 5 ( Simultaneous Cycleflash) as shown in the CHILD flash pattern table above. This will require momentarily touching the White wire to Ground for 1 to 3 seconds, and releasing, four times. Remove and re-apply power to the Parent and the Simultaneous Child. These two heads should now be flashing together in Cycleflash.

#### **Step 4**

Set the remaining two heads to CHILD mode by holding each of their White wires to Ground for 5 seconds or longer. These heads should now be in CHILD mode and in the factory default, Alternating Cycleflash, pattern. Remove and re-apply power to the PARENT and CHILD heads. These heads should now be Alternately Cycleflashing with the PARENT head.

Note: Anytime you are not sure if a CHILD head is in an Alternating or Simultaneous pattern you can always get back to the Alternating Cycleflash pattern by stepping through patterns until the SteadyBurn mode is reached. The next step will put the head into the Alternating Cycleflash pattern. Remember that any CHILD head must be connected to a PARENT head via the Grey wire, or to +12V, to enable flashing. PARENT heads will flash without any communications connections.

## 6-LED Flash Pattern Selection

This unit will provide up to twenty one different flash modes. Each of these modes can be selected by grounding and releasing the white wire. As each flash mode is selected it is automatically programmed into the unit such that when power is removed it will always return to the selected mode the next time power is applied.

### 6-LED Flash Modes:

#### Alternating

Cycle Flash  
 Single Flash  
 Double Flash  
 Triple Flash  
 Quad Flash  
 Five Flash  
 Fast Single Flash  
 Fast Double Flash  
 Fast Triple Flash  
 Fast Quad Flash  
 Quad Pop Flash  
 Triple Pop Flash  
 Double Pop Flash  
 Wig-Wag Flash Alt.

#### Simultaneous

Quad Flash  
 Triple Flash  
 Double Flash  
 Single Flash  
 Pursuit Flash

#### Steady with Flashing

Fast Double Flash w/Steady  
 Quad Flash w/Steady

**Note:** All modes flash at a rate of 70 fpm minimum. Fast modes flash at a rate of 100 fpm minimum.

## Maintenance:

The Exterior LED Modules are completely sealed units designed to be trouble and maintenance free. Refer to the guide below for help with troubleshooting. Should the unit be diagnosed as malfunctioning, remove unit and replace with a new module.

### TROUBLESHOOTING

Problem	Probable Cause	Remedy
Lighthouse does not activate	a. No Power to unit b. Power input wire reversed c. Damaged or shorted cabling d. Defective Lighthouse e. Control wire permanently grounded or shorted to GND	a. Check wiring for loose connection b. Reverse Power wires c. Check cables for damage d. Replace lighthouse module e. Avoid permanent grounding of control wire
Lighthouse is constantly ON	a. Control wire permanently grounded or shorted to GND	



LED module housings may become hot with extended use. Allow modules to cool completely before attempting to remove.

# WARRANTY

Code 3, Inc.'s L.E.D. emergency devices are tested and found to be operational at the time of manufacture. Provided they are installed and operated in accordance with manufacturer's recommendations, Code 3, Inc. guarantees all parts and components to a period of 5 years (unless otherwise expressed) from the date of purchase or delivery, whichever is later. Units demonstrated to be defective within the warranty period will be repaired or replaced at the factory service center at no cost.

Use of inappropriate or inadequate wiring or circuit protection causes this warranty to become void. Failure or destruction of the product resulting from abuse or unusual use and/or accidents is not covered by this warranty. Code 3, Inc. shall in no way be liable for other damages including consequential, indirect or special damages whether loss is due to negligence or breach of warranty.

**CODE 3, INC. MAKES NO OTHER EXPRESS OR IMPLIED WARRANTY INCLUDING, WITHOUT LIMITATION, WARRANTIES OF FITNESS OR MERCHANTABILITY, WITH RESPECT TO THIS PRODUCT.**

# PRODUCT RETURNS

If a product must be returned for repair or replacement\*, please contact our factory to obtain a Return Goods Authorization Number (RGA number) before you ship the product to Code 3, Inc. Write the RGA number clearly on the package near the mailing label. Be sure you use sufficient packing materials to avoid damage to the product being returned while in transit.

\*Code 3, Inc. reserves the right to repair or replace at its discretion. Code 3, Inc. assumes no responsibility or liability for expenses incurred for the removal and /or reinstallation of products requiring service and/or repair.; nor for the packaging, handling, and shipping; nor for the handling of products return to sender after the service has been rendered.

**PROBLEMS OR QUESTIONS? CALL OUR TECHNICAL ASSISTANCE HOTLINE (314) 996-2800**

**WWW.CODE3PSE.**

Code 3, Inc., a subsidiary of  
Public Safety Equipment, Inc.

**CODE 3**<sup>®</sup>  
PUBLIC SAFETY EQUIPMENT, INC.

Code 3, Inc.  
10986 N. Warson Road  
St. Louis, Missouri 63114-2029—USA  
Ph. (314) 426-2700 Fax (314) 426-1337

Part No. T07593 Rev. 2 2/21013

Code 3<sup>®</sup> is a registered trademark of Code 3, Inc., a subsidiary of Public Safety Equipment,

©2013 Code 3, Inc