

# INSTALLATION & OPERATION MANUAL

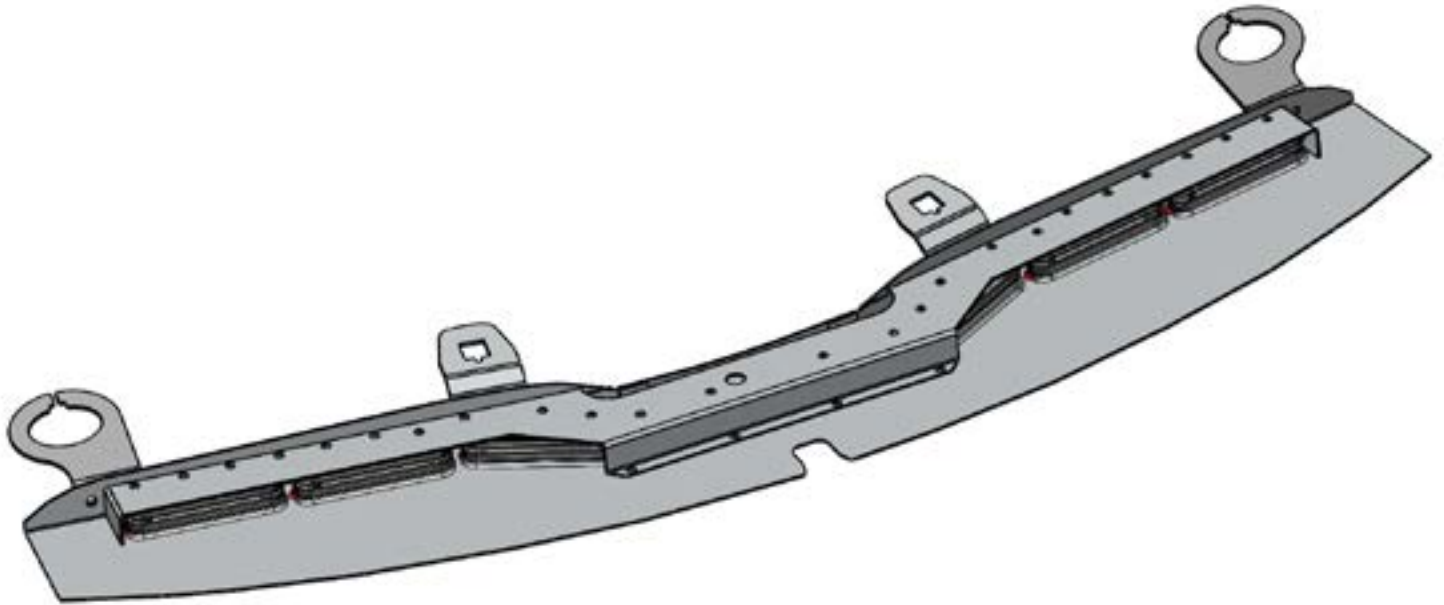

## SuperVisor-MC™ - 2011 Ford PI Utility With Multi Color Torus™ Technology Interior Lighting System

### CONTENTS:

Introduction.....	2
Unpacking & Pre-Installation .....	2
Installation & Mounting.....	3-4
Wiring Instructions Diagrams.....	4-6
LED Flash Rate / Sequence Selection.....	7
Cruise, Take Down Steady.....	8
Exploded View, Parts & Hardware List.....	8-9
Trouble Shooting, Notes:.....	10-11
Warranty .....	12

For future reference, record your product's serial no. here \_\_\_\_\_

**IMPORTANT:**

*Read all instructions and warnings before installing and using.*

**INSTALLER:**

*This manual must be delivered to the end user of this equipment.*

## Introduction

The Multi Color SuperVisor-MC™ (hereafter called "Unit") is an interior lighting system that fits in the visor area near the top of the windshield. The SuperVisor-MC has room for up to (6) Torus Multi Color Light Heads.

## Product Features

Torus Multi Color Light Head Options: Red/White, Blue/White, Amber/White, Red/Blue, Red/Amber, Blue/Amber

Size: 48.79" long x 1.70" tall x 10.24" deep-----Weight: 7.5 lbs



The use of this or any warning device does not ensure that all drivers can or will observe or react to an emergency warning signal. Never take the right-of-way for granted. It is your responsibility to be sure you can proceed safely before entering an intersection, driving against traffic, responding at a high rate of speed, or walking on or around traffic lanes. The effectiveness of this warning device is highly dependent upon correct mounting and wiring. Read and follow the manufacturer's instructions before installing or using this device. The vehicle operator should insure daily that all features of the device operate correctly. In use, the vehicle operator should insure the projection of the warning signal is not blocked by vehicle components (i.e.: open trunks or compartment doors), people, vehicles, or other obstructions. This equipment is intended for use by authorized personnel only. It is the user's responsibility to understand and obey all laws regarding emergency warning devices. The user should check all applicable city, state and federal laws and regulations. Code 3, Inc., assumes no liability for any loss resulting from the use of this warning device. Proper installation is vital to the performance of this warning device and the safe operation of the emergency vehicle. It is important to recognize that the operator of the emergency vehicle is under psychological and physiological stress caused by the emergency situation. The warning device should be installed in such a manner as to: A) Not reduce the output performance of the system, B) Place the controls within convenient reach of the operator so that he can operate the system without losing eye contact with the roadway. Emergency warning devices often require high electrical voltages and/or currents. Properly protect and use caution around live electrical connections. Grounding or shorting of electrical connections can cause high current arcing, which can cause personal injury and/or severe vehicle damage, including fire. Any electronic device may create or be affected by electromagnetic interference. After installation of any electronic device operate all equipment simultaneously to insure that operation is free of interference. Never power emergency warning equipment from the same circuit or share the same grounding circuit with radio communication equipment. All devices should be mounted in accordance with the manufacturer's instructions and securely fastened to vehicle elements of sufficient strength to withstand the forces applied to the device. Driver and/or passenger air bags (SRS) will affect the way equipment should be mounted. This device should be mounted by permanent installation and within the zones specified by the vehicle manufacturer, if any. Any device mounted in the deployment area of an air bag will damage or reduce the effectiveness of the air bag and may damage or dislodge the device. Installer must be sure that this device, its mounting hardware and electrical supply wiring does not interfere with the air bag or the SRS wiring or sensors. Mounting the unit inside the vehicle by a method other than permanent installation is not recommended as unit may become dislodged during swerving, sudden braking or collision. Failure to follow instructions can result in personal injury. **PROPER INSTALLATION COMBINED WITH OPERATOR TRAINING IN THE PROPER USE OF EMERGENCY WARNING DEVICES IS ESSENTIAL TO INSURE THE SAFETY OF EMERGENCY PERSONNEL AND THE PUBLIC.**

## Unpacking & Pre-installation

Carefully remove the Unit and place it on a flat surface, taking care not to scratch the lenses or damage the cable coming out of the Housing. Examine the unit for transit damage, broken optics, LED's, etc. Report any damage to the carrier and keep the shipping carton.

The Multi Color SuperVisor-MC light bar is built to operate on 12 volt D.C. negative ground (earth). The Unit will not operate properly if you have an electrical system other than 12 volt D.C. negative ground (earth).

Test the unit before installation. To test, touch the black wire to the ground (earth) and the other wires to +12 volts D.C., in accordance with the instructions attached to the cable and as shown in the Multi Color SuperVisor Internal Wiring Diagram at the top of page 7 of this manual (an automotive battery is preferable for this test). A battery charger may be used, but note that some electronic options may not operate normally when powered by a battery charger. If problems occur at this point, contact the factory.

**WARNING!**



Utilizing non-factory supplied screws and/or mounting brackets and/or the improper number of screws may result in loss of warranty coverage on the equipment.

**Mounting Hardware** - All mounting hardware is packed in a small bag inside the main carton. There are four brackets used to mount the SuperVisor to the vehicle. These are discussed in detail later.

# Installation and Mounting Instructions

**Step 1** Remove the plastic covers from the driver and passenger outer sun visor pivot brackets (see Figures 1 & 2). Remove the (2) small Torx screws as shown in Figures 3 and 4 from each pivot bracket. Pull the visor pivot brackets down from the headliner and carefully allow the sun visors to hang by the vehicle's attached vanity mirror light wires.

**Step 2** Unscrew the single Torx screw holding each of the vehicle's (2) inner visor clips in place as shown in Figure 5.

**Step 3** Attach the vehicle's inner visor clips to the SuperVisor Inner Mounting Brackets as shown in Figure 6. Thread each of the vehicles Torx screws you removed in step 2 above all the way up into the vehicle's plastic inner visor clip (**this makes it easier to see the end of the screw so you can thread the screw into it's hole in the headliner**). Position the SuperVisor Inner Mounting Brackets up to the headliner as shown in figure 7 page 4 and loosely thread the screws into the screw hole in the vehicle's headliner. Tighten the screws until the brackets are within about 1/8" of the headliner. Do not fully tighten the screws at this time.

**Step 4** Attach the vehicle's plastic outer visor pivot brackets to the supplied SuperVisor Outer Mounting Brackets noting the difference between the passenger and driver side and thread the (2) Torx screws as shown in Figure 8 on page 4 (**Drivers Side Shown**). Tighten the screws until the brackets are within about 1/8" of the headliner. Do not fully tighten the screws at this time.

**Step 5** Route the SuperVisor's cable to the desired side of the vehicle and out the end of the SuperVisor's Outer Panel. Make sure the cable will not interfere with the vehicle's headliner and windshield as you position the SuperVisor up to the headliner in front of the SuperVisor Inner and Outer Mounting Brackets as shown in Figure 9 page 4.

**Step 6** Line up the slots in the SuperVisor Inner Mounting Brackets with the threaded holes in the SuperVisor, and thread the supplied 1/4"-20 screws and internal tooth lock washers through the slots and into the SuperVisor's Outer Panel (see Figure 10 page 4).

**Step 7** Line up the slots in the SuperVisor's Outer Mounting Brackets with the threaded holes in the SuperVisor, and Thread the supplied 1/4"-20 screws and internal tooth lock washers through the slot in the SuperVisor's Outer Mounting Brackets and into the SuperVisor's Outer Panel (see Figure 11 page 4).

**Step 8** Make sure the SuperVisor is exactly centered in the vehicle and tighten all (6) of the vehicle's the Torx screws in the SuperVisor's Inner and Outer Mounting Brackets (Inner Brackets see Figure 12 page 4 - Outer Brackets see Figure 13 page 4).

**Step 9** While pushing the SuperVisor very tightly up against the headliner, tighten the (2) 1/4"-20 SuperVisor Inner Mounting Bracket screws as shown in Figure 14 then again while pushing the SuperVisor very tightly up against the headliner, tighten the (2) 1/4"-20 SuperVisor Outer Mounting Bracket screws as shown in Figure 15 page 4. **Note: It is best to have an assistant push up on the SuperVisor while you tighten the screw to assure that it is tight against the vehicle's headliner.**

**Step 10** Replace the plastic covers on the driver and passenger outer sun visor pivot brackets (see Figure 16 page 4).



**FIGURE 1**



**FIGURE 2**



**FIGURE 3**



**FIGURE 4**



**FIGURE 5**



**FIGURE 6**

## Installation and Mounting Instructions: Cont.



**FIGURE 7**



**FIGURE 8-DRIVER SIDE SHOWN**



**FIGURE 9**



**FIGURE 10**



**FIGURE 11**



**FIGURE 12**



**FIGURE 13**

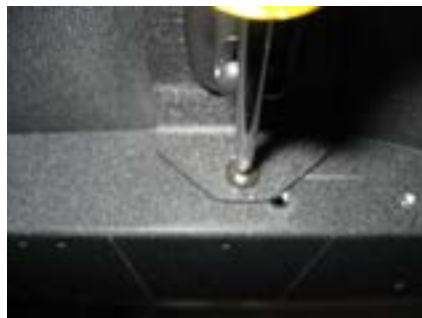

**FIGURE 14**



**FIGURE 15**



**FIGURE 16**

**Caution:** Drilling into the housing of the light bar could damage wiring or other internal components.

### Wiring Instructions

Finish routing the cable as desired. It is advisable to leave an extra loop of cable when installing the light bar to allow for future changes or reinstallations. For wiring of the Multi Color SuperVisor, see pages 5 & 6.

### LED Fusing Considerations

**NOTE:** The Components of the Multi Color SuperVisor System are circuit protected by the Multi Color SuperVisor System CC Board so the individual wires in the System do not require fusing.



**WARNING!**

**DO NOT APPLY 12 VOLTS DIRECTLY TO THE SUPERVISOR WIRES AFTER IT IS CONNECTED TO THE SUPERVISOR MULTI COLOR CC BOX. THE MULTI COLOR SUPERVISOR CC BOARD OR THE LIGHT HEADS COULD BE DAMAGED BY APPLYING 12 VOLTS TO THE CC OUTPUTS!**

**WARNING:** This unit must be mounted within the interior passenger compartment of the vehicle only. It is not intended for use in exterior applications. All devices should be mounted in accordance with the manufacturer's instructions and securely fastened to vehicle elements of sufficient strength to withstand the forces applied to the device. Driver and/or passenger air bags (SRS) will affect the way equipment should be mounted. This device should be mounted by permanent installation and within the zones specified by the vehicle manufacturer, if any. Any device mounted in the deployment area of an air bag will damage or reduce the effectiveness of the air bag and may damage or dislodge the device. Installer must be sure that this device, its mounting hardware and electrical supply wiring does not interfere with the air bag or the SRS wiring or sensors. Mounting the unit inside the vehicle by a method other than permanent installation is not recommended as unit may become dislodged during swerving, sudden braking or collision. Failure to follow instructions can result in personal injury.



Larger wires and tight connections will provide longer service life for components. For high current wires it is highly recommended that terminal blocks or soldered connections be used with shrink tubing to protect the connections. Do not use insulation displacement connectors (e.g. 3M® Scotchlock type connectors). Route wiring using grommets and sealant when passing through compartment walls. Minimize the number of splices to reduce voltage drop. High ambient temperatures (e.g. under hood) will significantly reduce the current carrying capacity of wires, fuses, and circuit breakers. Use "SXL" type wire in engine compartment. All wiring should conform to the minimum wire size and other recommendations of the manufacturer and be protected from moving parts and hot surfaces. Looms, grommets, cable ties, and similar installation hardware should be used to anchor and protect all wiring. Fuses or circuit breakers should be located as close to the power takeoff points as possible and properly sized to protect the wiring and devices. Particular attention should be paid to the location and method of making electrical connections and splices to protect these points from corrosion and loss of conductivity. Ground terminations should only be made to substantial chassis components, preferably directly to the vehicle battery. The user should install a fuse sized to approximately 125% of the maximum Amp capacity in the supply line to protect against short circuits. For example, a 30 Amp fuse should carry a maximum of 24 Amps. **DO NOT USE 1/4" DIAMETER GLASS FUSES AS THEY ARE NOT SUITABLE FOR CONTINUOUS DUTY IN SIZES ABOVE 15 AMPS.** Circuit breakers are very sensitive to high temperatures and will "false trip" when mounted in hot environments or operated close to their capacity.

### MULTI COLOR SUPERVISOR INTERNAL WIRING DIAGRAM

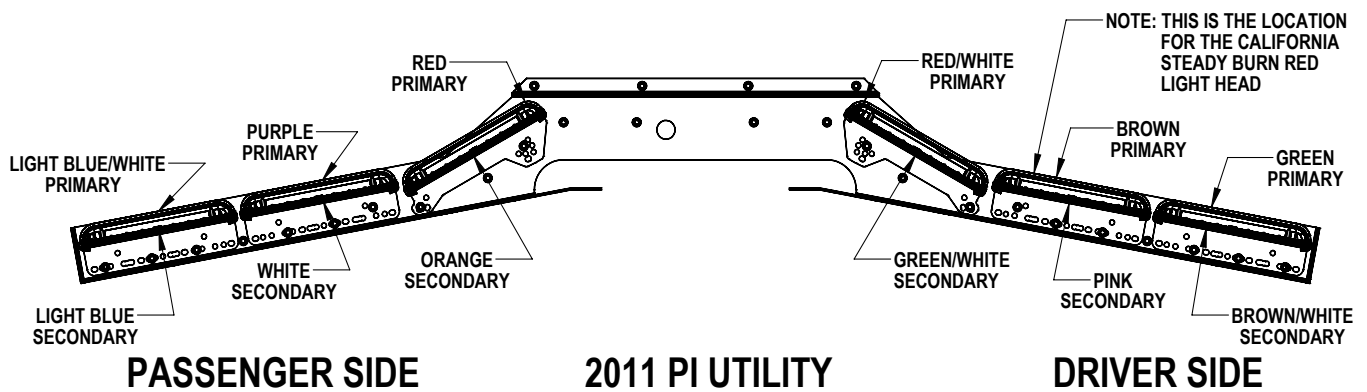

# MULTI COLOR SUPERVISOR & CC WIRING DIAGRAM

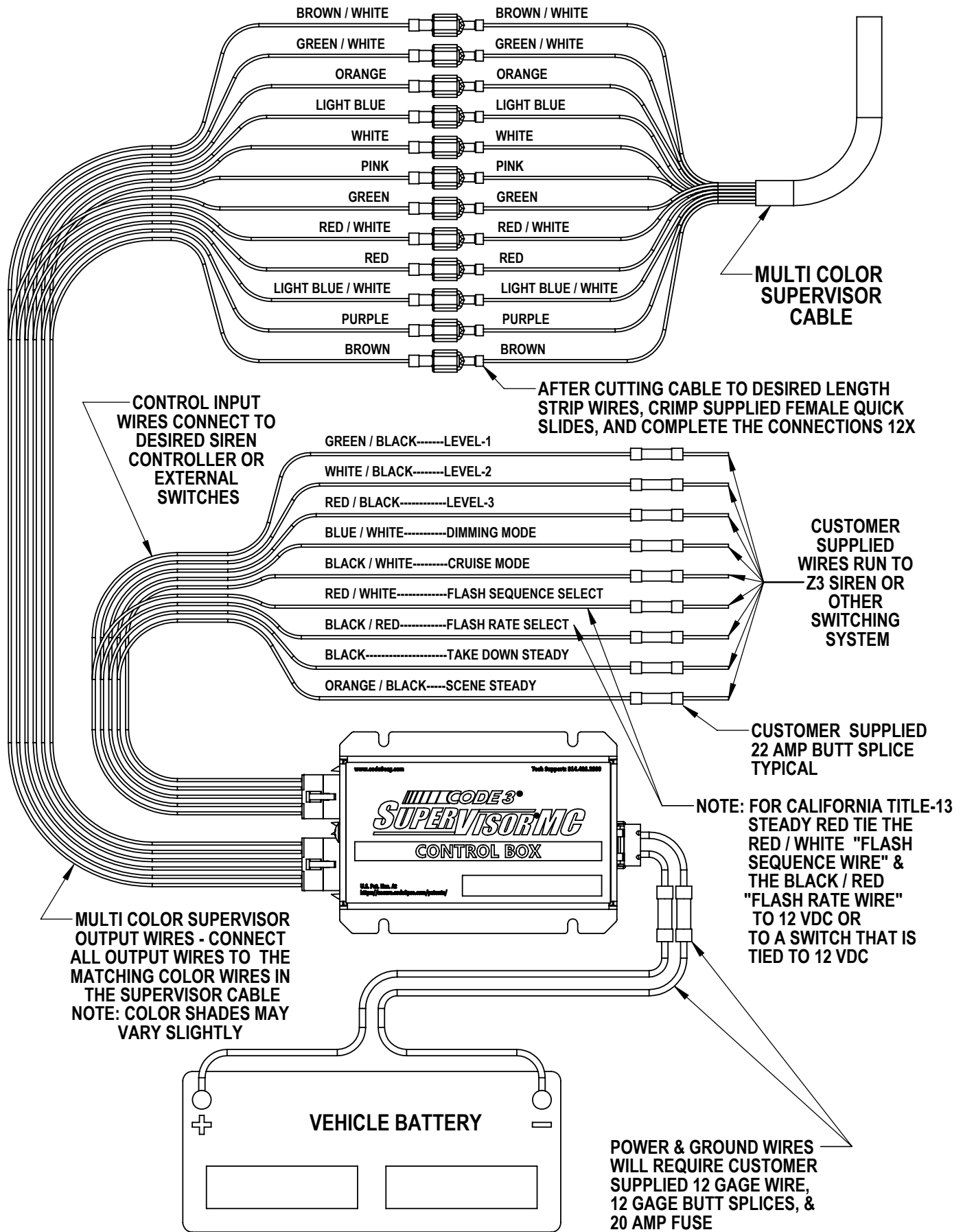

# WARNING!



This Product contains high intensity LED devices. To prevent eye damage, DO NOT stare into light beam at close range.

## Changing Flash Rates and Lighting Sequences

To change Multi Color SuperVisor Light Head flash rates, momentarily touch the Black Wire with Red Stripe (Flash Rate Control Wire) to 12 VDC Power (+ Positive). By holding the wire to + Positive for (1) second it will advance the flash rate by one, by holding the wire to + Positive for (3) seconds it will move the flash rate back by one. Holding the wire to + Positive for (5) seconds will set the flash rate back to the factory default setting. See Flash Rate Chart Below! Changing the flash Sequence works the same way except you use the Red Wire with White Stripe (Flash Sequence Control Wire). See Sequence Chart below!

### Sequence

### Primary / Secondary Colors

### Light Head Flash Rates

#### Multi Color SuperVisor

LEFT / RIGHT  
(DEFAULT)

PRIMARY & SECONDARY  
PRIMARY ONLY - **LEVEL - 1 DEFAULT**  
SECONDARY ONLY  
PRIMARY W / WHITE POPS - **LEVEL - 3 DEFAULT**  
PRIMARY W / WHITE RANDOM

Double Flash-75 - **LEVEL - 2 DEFAULT**  
Triple Flash-75  
Quad Flash-75  
Quint Flash-75  
Double Flash-150 - **LEVEL - 3 DEFAULT**

EVEN / ODD

PRIMARY & SECONDARY  
PRIMARY ONLY - **LEVEL - 2 DEFAULT**  
SECONDARY ONLY  
PRIMARY W / WHITE POPS  
PRIMARY W / WHITE RANDOM

Triple Flash-150 - **LEVEL - 1 DEFAULT**  
Quad Flash-150  
Quint Flash-150  
Triple Pop Flash-150  
Quad Pop Flash-150

IN / OUT

PRIMARY & SECONDARY  
PRIMARY ONLY  
SECONDARY ONLY  
PRIMARY W / WHITE POPS  
PRIMARY W / WHITE RANDOM

Single Flash-375  
Cycle Rates

RANDOM

PRIMARY & SECONDARY  
PRIMARY ONLY  
SECONDARY ONLY  
PRIMARY W / WHITE POPS  
PRIMARY W / WHITE RANDOM

### INSTALLER NOTE:

**FLASH RATE + FLASH SEQUENCE = FLASH PATTERN**

CYCLE SEQUENCE  
RANDOM

PRIMARY & SECONDARY  
PRIMARY ONLY  
SECONDARY ONLY  
PRIMARY W / WHITE POPS  
PRIMARY W / WHITE RANDOM

ALL ON  
RANDOM

PRIMARY & SECONDARY

SWEEP  
LEFT / RIGHT

PRIMARY & SECONDARY  
PRIMARY ONLY  
SECONDARY ONLY  
PRIMARY W / WHITE POPS  
PRIMARY W / WHITE RANDOM

**Cruise is configurable to any symetric setting.**  
**TD Steady is configurable to any symetric setting.**

<b><u>Cruise</u></b>	<b><u>TD Steady</u></b>	<b><u>Scene Steady</u></b>
2 Outer Secondary Steady	2 Inner Secondary	All 6 Secondary
2 Outer Secondary Flicker	2 Middle Secondary	
4 Outer Secondary Steady	2 Outer Secondary	
4 Outer Secondary Flicker	4 Inner/Middle Secondary	
6 Outer Secondary Steady	4 Outer/Middle Secondary	
6 Outer Secondary Flicker	4 Inner/Outer Secondary	

Cruise is lowest priority and will not work when any other feature is enabled. Different combinations of lights can be used as Cruise by tapping the Sequence wire to +12V while **only the Cruise** is turned on.

TD Steady will work with or without Level 1, 2, or 3 lights engaged. Different combinations of lights can be used as the TD by tapping the Sequence wire to +12V while only the TD Steady is turned on.

**Scene Steady overrides all other functions.**

### **Parts List - Multi Color SuperVisor-MC**

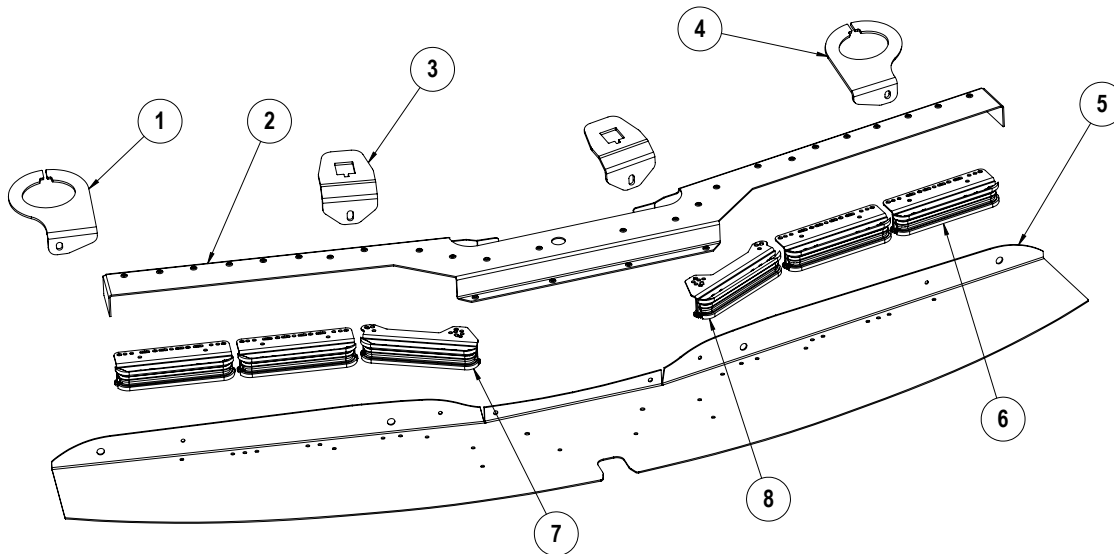

<b><u>Reference Number</u></b>	<b><u>Part Description</u></b>	<b><u>Part Number</u></b>	<b><u>Quantity</u></b>
1	Outer Mtg. Brkt. Dodge Charger Pass Side	T15387	1
2	Chassis TL	T15395	1
3	Inner Mtg. Brkt. Dodge Charger	T15394	2
4	Outer Mtg. Brkt. Dodge Charger Drivr Side	T15386	1
5	Outer Panel	T15375	1
6	Torus Multi Color Forward Facing Lt Head Module	Contact Code 3, Inc for P/N	4
7	Torus Multi Color Passenger Intersection Lt Head Module	Contact Code 3, Inc for P/N	1
8	Torus Multi Color Driver Intersection Lt Head Module	Contact Code 3, Inc for P/N	1

**Note:** Some of the above listed parts may not be available for purchase!



## Parts List - CC Box - SuperVisor-MC - Multi Color

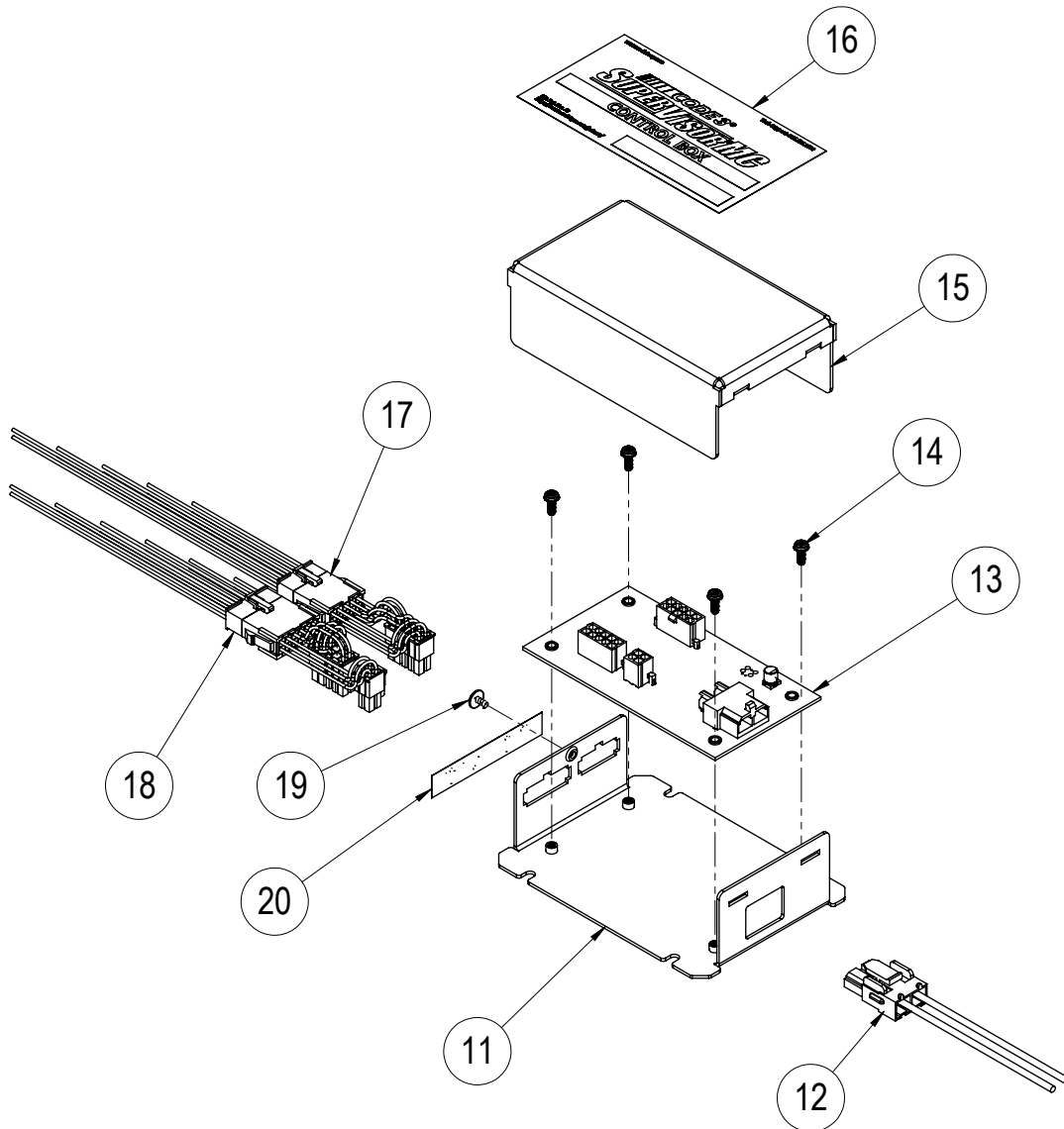

<u>Reference Number</u>	<u>Part Description</u>	<u>Part Number</u>	<u>Quantity</u>
11	E-Tray - Multi Color SuperVisor	T17164	1
12	Power Ground Cable--Mass State Police Slick Top System	T56637	1
13	PCB Central Controller-Midrange	T57137	1
14	#6-32 X.375 Phil Rd M/S, Stl, Zinc	T04250	4
15	Cover-CC Housing-Multi Color SuperVisor	T17165	1
16	Label-CC Box-Multi Color SuperVisor	T17168	1
17	Input Harness-Multi Color SuperVisor CC Box	T17166	1
18	Output Harness-Multi Color SuperVisor CC Box	T17167	1
19	#8 X .25 SMS Phillips Truss Head Screw-Black Oxided	T89905	1
20	Label-CC Box-Multi Color SuperVisor-INPUT/OUTPUT	T17168	Part of Item 16 Above

## Troubleshooting

All SuperVisor-MCs are thoroughly tested prior to shipment. However, should you encounter a problem during installation or during the life of the product, follow the guide below for information on repair and troubleshooting. Additional information may be obtained from the factory technical help line at 314-996-2800. Follow the guide below for information on repair and troubleshooting.

### TROUBLESHOOTING GUIDE

**Note: LED modules must be replaced as a module. There are no user serviceable parts.**

PROBLEM	QUESTIONS	POSSIBLE CAUSE	SOLUTION
LED module not operating when powered.	N/A	A. Bad power/ground connection. B. Defective module.	A. Fix connection. B. Replace module

### Notes

## Notes

# WARRANTY

Code 3, Inc.'s emergency devices are tested and found to be operational at the time of manufacture. Provided they are installed and operated in accordance with manufacturer's recommendations, Code 3, Inc. guarantees all parts and components except the lamps to a period of 1 year, LED Lighthouse modules to a period of 5 years (unless otherwise expressed) from the date of purchase or delivery, whichever is later. Units demonstrated to be defective within the warranty period will be repaired or replaced at the factory service center at no cost.

Use of lamp or other electrical load of a wattage higher than installed or recommended by the factory, or use of inappropriate or inadequate wiring or circuit protection causes this warranty to become void. Failure or destruction of the product resulting from abuse or unusual use and/or accidents is not covered by this warranty. Code 3, Inc. shall in no way be liable for other damages including consequential, indirect or special damages whether loss is due to negligence or breach of warranty.

**CODE 3, INC. MAKES NO OTHER EXPRESS OR IMPLIED WARRANTY INCLUDING, WITHOUT LIMITATION, WARRANTIES OF FITNESS OR MERCHANTABILITY, WITH RESPECT TO THIS PRODUCT.**

# PRODUCT RETURNS

If a product must be returned for repair or replacement\*, please contact our factory to obtain a Return Goods Authorization Number (RGA number) before you ship the product to Code 3, Inc. Write the RGA number clearly on the package near the mailing label. Be sure you use sufficient packing materials to avoid damage to the product being returned while in transit.

\*Code 3, Inc. reserves the right to repair or replace at its discretion. Code 3, Inc. assumes no responsibility or liability for expenses incurred for the removal and/or reinstallation of products requiring service and/or repair; nor for the packaging, handling, and shipping; nor for the handling of products returned to sender after the service has been rendered.

**NEED HELP? Call our Technical Assistance HOTLINE - (314) 996-2800**

**Code 3®, Inc.**  
10986 N. Warson Road  
St. Louis, Missouri 63114-2029—USA  
Ph. (314) 426-2700 Fax (314) 426-1337  
[www.code3pse.com](http://www.code3pse.com)