

INSTALLATION & OPERATION MANUAL

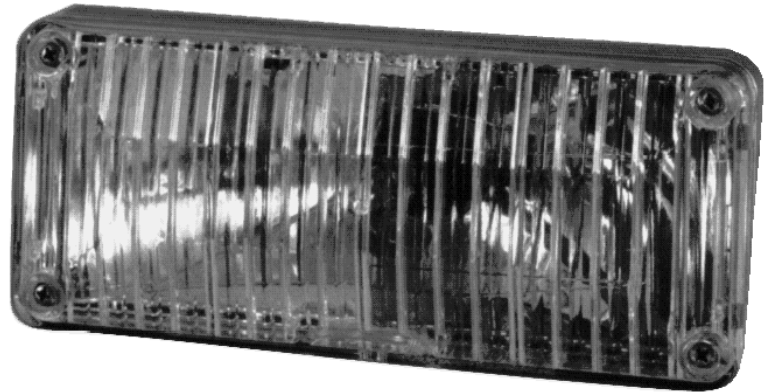

SERIES 40/41/42
STROBE AND HALOGEN
PERIMETER LIGHT HEADS

Code 3, Inc., a subsidiary of
Public Safety Equipment, Inc.

CODE 3[®]
INC.
PUBLIC SAFETY EQUIPMENT, INC.

SERIES 40/41/42

STROBE AND HALOGEN PERIMETER LIGHT HEADS

Contents:

Introduction	2
Unpacking & Pre-Installation	2
Installation	3-4
Parts & Exploded View	5
Maintenance	6
Options	6
Warranty	8

IMPORTANT:

Read all instructions and warnings before installing and using.

INSTALLER

This manual must be delivered to the end user of this equipment.

Introduction

The 40/41/42 Series Perimeter Light Heads are designed for the emergency vehicle market. The light heads are to be connected to the Code 3® 475, 460, 235, or 440 Strobe Power Supplies (Strobe Model 40) or +12 VDC output electromechanical or solid state flasher units (Halogen Models 41, 42), with the optional cable assemblies. These light heads with unique faceted shape are designed for optimum lighting at all angles. The Strobe Model 40 meets and exceeds the SAE J1318 and California Title XIII output requirements for directional gaseous discharge lamps. The Halogen Model 42 with the 65W Transverse filament lamp assembly (S95285) exceeds the requirements of KKK-A-1822E.

Consisting of a lens, lamp assembly, reflector assembly, optional bezel and mounting fasteners, the Series 40, 41 and 42 Light Heads are easy to install. The design allows for interchangeability between the 40 Series Strobe Light Heads and the 41/42 Series Halogen Light Heads giving the user freedom to customize the vehicle's lighting system.



WARNING!

The use of this or any warning device does not insure that all drivers can or will observe or react to an emergency warning signal. Never take the right-of-way for granted. It is your responsibility to be sure you can proceed safely before entering an intersection, driving against traffic, responding at a high rate of speed, or walking on or around traffic lanes.

The effectiveness of this warning device is highly dependent upon correct mounting and wiring. Read and follow the manufacturer's instructions before installing or using this device. The vehicle operator should insure daily that all features of the device operate correctly. In use, the vehicle operator should insure the projection of the warning signal is not blocked by vehicle components (i.e.: open trunks or compartment doors), people, vehicles, or other obstructions. This equipment is intended for use by authorized personnel only. It is the user's responsibility to understand and obey all laws regarding emergency warning devices. The user should check all applicable city, state and federal laws and regulations.

Public Safety Equipment, Inc., assumes no liability for any loss resulting from the use of this warning device.

Proper installation is vital to the performance of this warning device and the safe operation of the emergency vehicle. It is important to recognize that the operator of the emergency vehicle is under psychological and physiological stress caused by the emergency situation. The warning device should be installed in such a manner as to: A) Not reduce the output performance of the system, B) Place the controls within convenient reach of the operator so that he can operate the system without losing eye contact with the roadway.

Emergency warning devices often require high electrical voltages and/or currents. Properly protect and use caution around live electrical connections. Grounding or shorting of electrical connections can cause high current arcing, which can cause personal injury and/or severe vehicle damage, including fire. Do not touch the strobe light tubes, the strobe light head assemblies or the strobe power supply while the system is in operation. Wait 10 minutes after turning off the power from system before touching any internal components. Always wear hand and eye protection when handling strobe or halogen lamps. The lamps are pressurized and breakage could result in injury from flying gas.

PROPER INSTALLATION COMBINED WITH OPERATOR TRAINING IN THE PROPER USE OF EMERGENCY WARNING DEVICES IS ESSENTIAL TO INSURE THE SAFETY OF EMERGENCY PERSONNEL AND THE PUBLIC.

Unpacking And Pre-Installation

Carefully remove the light head from its protective packaging. Inspect the unit for transit damage (broken lamp assembly, etc). Report any damage to the carrier and keep the shipping carton. Verify that four #6 x 1-1/2" screws per lighthouse are included. The optional three wire cable comes in a 15, 20 or 25 foot length. Both ends have Amp #60619-1 sockets attached to each wire. The cable comes with a parts bag consisting of 2 AMP #1-480303-0 Mate-N-Lock socket housings and 1 #8 noninsulated ring terminal. Verify that these items are also included.

Installation

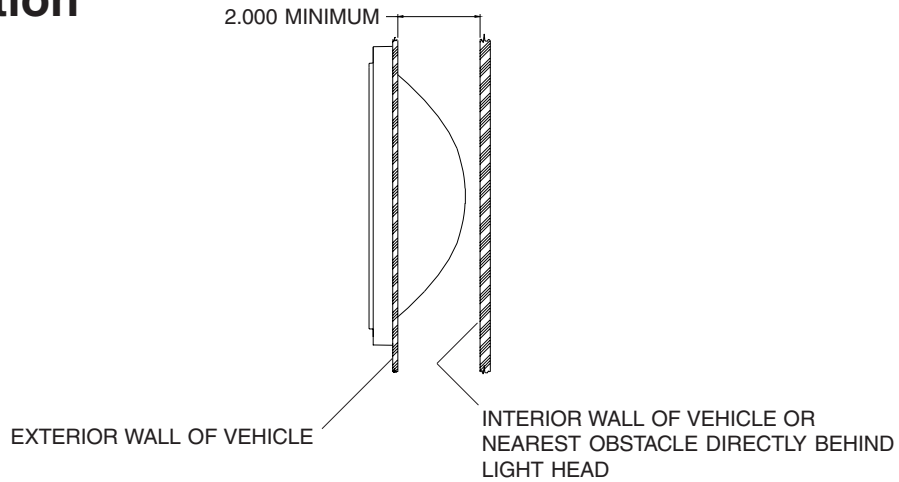

FIGURE 1

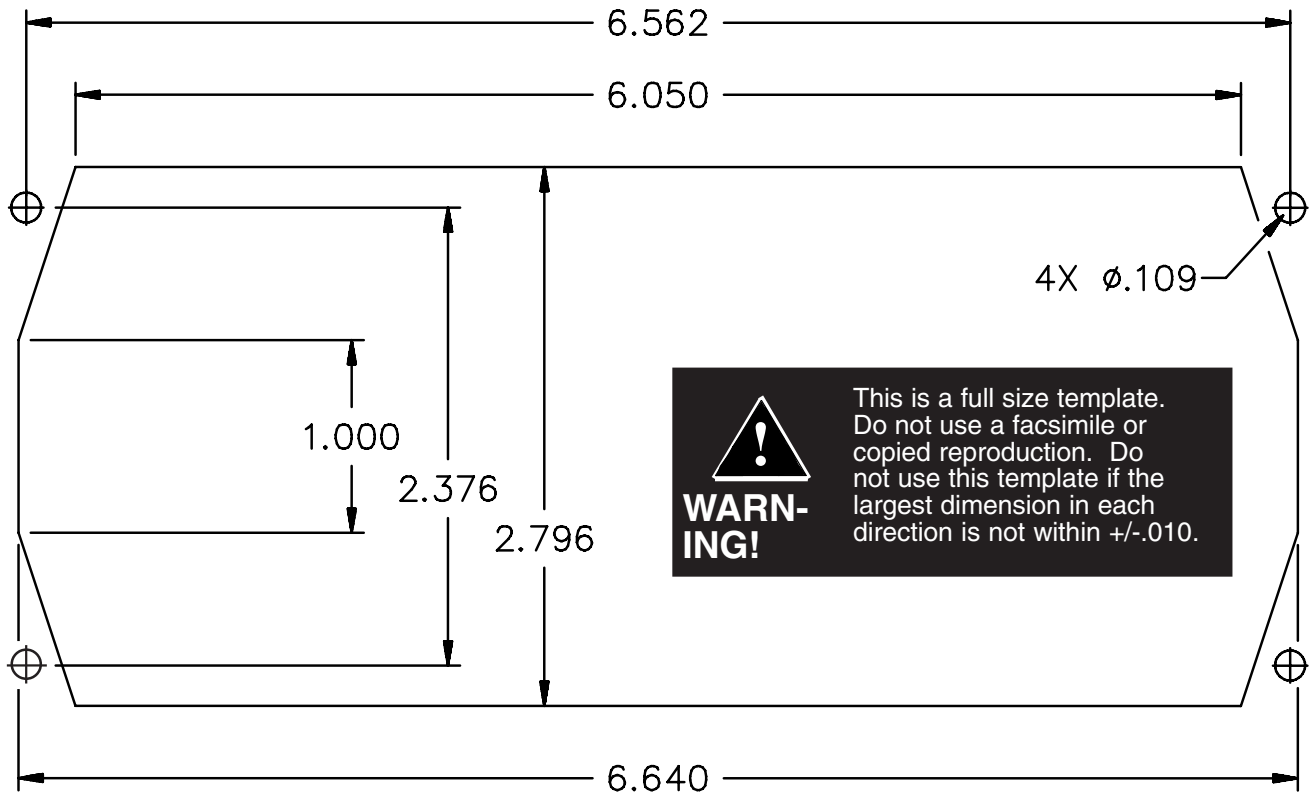

FIGURE 2

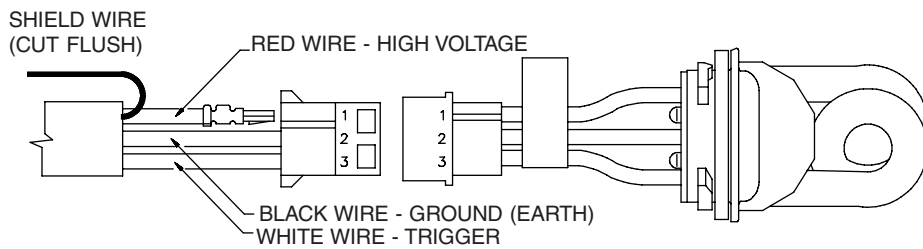
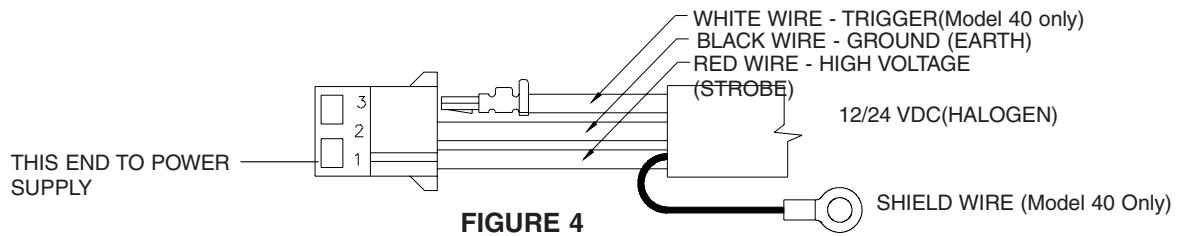



FIGURE 3

1. Select the desired mounting location for the strobe light head assembly.
2. Verify 2 inches minimum free clearance behind the mounting surface, see Figure 1.
3. Cut the opening and drill the holes, use Figure 2 template or the trim bezel if your light head is so equipped.
4. With one end of the cable at the light head mounting location, route the three wire cable to the Power Supply.
5. At the light head end of the cable, insert the 3 AMP sockets into the AMP socket housing as shown in Figure 3. Cut the shield wire flush with the jacket. (Strobe Lamp Assembly shown. Procedure is the same for Halogen Lamp Assembly.)
6. Allow 3 inches minimum slack at the light head to facilitate lamp assembly replacement. Secure the cable.
7. At the power source end of the cable determine if the cable length is acceptable. If a shorter length is required, coil the cable and tie with an electrical tie.
8. Insert the 3 AMP sockets into the AMP socket housing as shown in Figure 4.
9. Crimp the #8 ring terminal to the shield wire and attach to nearest grounded structure. (Strobe Model 40 Only.)



For 40, 41 or 42 series models with optional bezel snap the reflector into the bezel making sure the reflector's "TOP" aligns with the bezel's 7023 product number. To insure proper sealing between the bezel and the mounting surface, align the supplied bezel gasket with the details in the back of the bezel.

10. Test the lamp assembly (strobe or halogen) by connecting the reflector assembly to the cable and the cable to the power source per the instructions with the power source.
11. Push the assembled AMP Mate-N-Lock connectors through the cut out in the vehicle.
12. Verify the '7021' product number on the reflector is on the top. Verify the "TOP" lens engraving is on the top. Mount the reflector and lens by installing the four screws.



Light head must be mounted so that back side of reflector and bulb insertion area is enclosed and shielded from weather.

WARNING!

Parts & Exploded Views

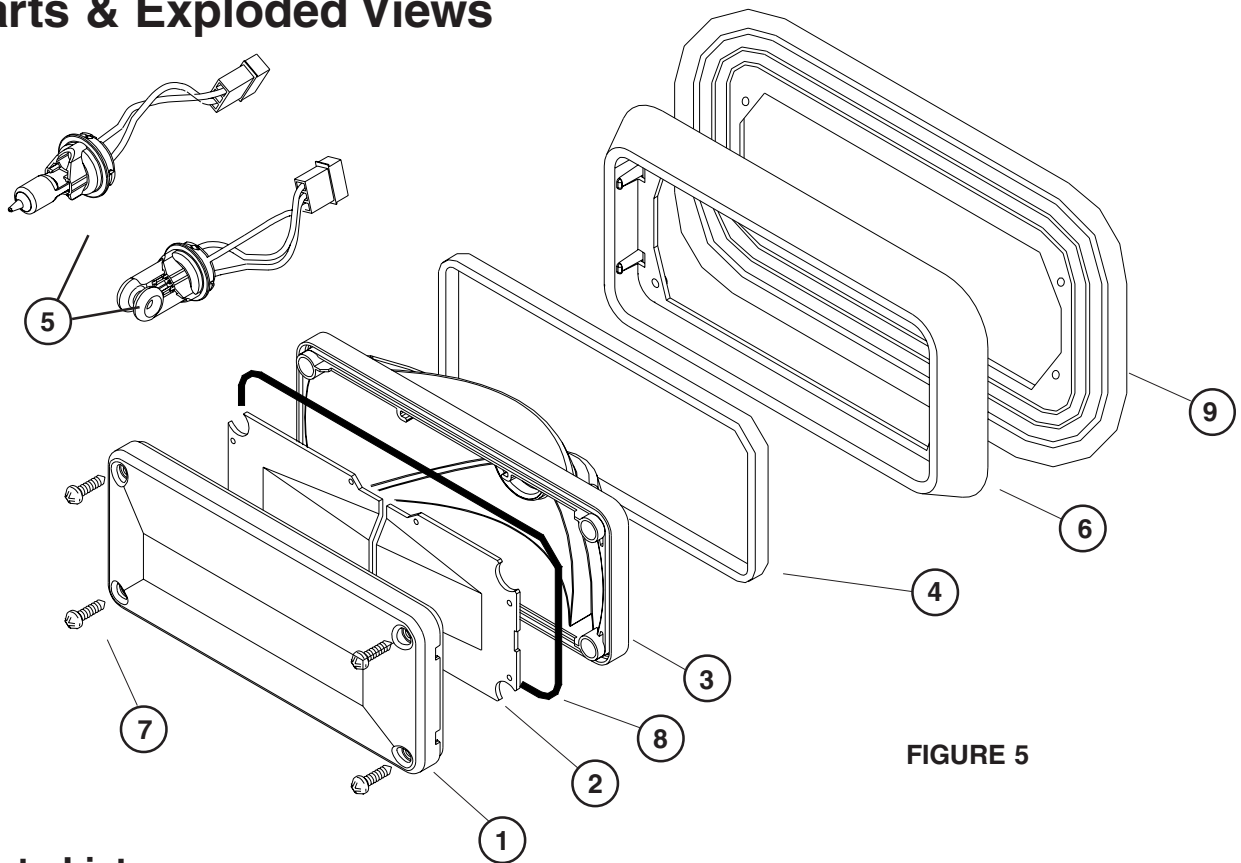

FIGURE 5

Parts List

Ref No.	Description	Part No.
1	Lens	T02270 (Green) T02271 (Clear) T02272 (Red) T02273 (Blue) T02274 (Amber) T02275 (Din Blue)
2	Filter Half (2 shown)	T02282 (Red) T02283 (Blue) T02284 (Amber)
3	Reflector	T07021
4	Gasket	T05328
5	Lamp Assembly	(Strobe) (Halogen) T07008 S82110(12v 50w red dot) S95285(12v 65w Transverse black dot-For KKK-A-1822E Model 42 only) S85347(24v 50w upgrade purple dot) S82120(12v 35w blue dot)
6	Trim Bezel	T07023
7	#6 Sheet Metal Screw, 1.75 long	T07028
8	Rope Gasket	T07005
9	Bezel Gasket	T03884

Maintenance

Lamp Assembly Replacement



WARNING!

High voltages and /or temperatures are present inside the unit. Disconnect from power and wait 10 minutes prior to servicing or troubleshooting. Use hand and eye protection when changing halogen lamps or flashtubes as they are pressurized and accidental breakage can result in flying glass. Lamps are extremely hot! Allow to cool completely before attempting to remove. Gloves and eye protection should be worn handling halogen lamps or flashtubes as they are pressurized and accidental breakage can result in flying glass.

1. Turn off power to the power supply and allow the lamp assembly to cool for 10 minutes.
2. Remove the lens by unscrewing the four mounting screws.
3. Carefully grasp the base of the lamp assembly and twist counterclockwise 1/8 turn. Pull straight out.
4. Disconnect the lamp assembly from the cable.
5. Insert the replacement lamp assembly into the reflector. Twist clockwise 1/8 turn until you feel the locking features of the socket engage.
6. Test the lamp assembly by connecting the lamp assembly to the cable. Switch the power source on. After verifying the tube is good, turn off the power source.
7. Push the assembled AMP Mate-N-Lock connectors through the cut out in the vehicle for the reflector.
8. Verify the "7021" product number on the reflector is on the top. Verify "TOP" lens engraving is on the top of the lens. Mount the reflector and lens by installing the four screws.

Lens Cleaning

1. Remove the lens by unscrewing the four mounting screws.
2. Using plain water and a soft cloth, or Code 3 lens polish and a very soft paper towel or facial tissue clean both surfaces of the lens.
3. Because plastic scratches easily, cleaning is recommended only when necessary (about every six months).
4. Do not subject the lenses to car washes that use brushes, as these will scratch the lenses.



WARNING!

If attempting to clean the reflector, use only a mild glass cleaner and a very soft cloth. Do not attempt to use any wax type products as these will burn onto the reflector and impair effectiveness.

Options

The 40/41/42 Series Strobe and Halogen Perimeter Lighting Product Group includes the following models:

Single Products

Strobe

- 40** Strobe tube assembly, reflector and lens
choice of six lens colors: amber, blue, clear, din blue, green and red.
Clear lens can be specified with optional inserted half lenses. Available in amber, blue, and red.
- 40BZ** Strobe tube assembly, bezel, reflector and lens
choice of six lens colors: amber, blue, clear, din blue, green and red.
Clear lens can be specified with optional inserted half lenses. Available in amber, blue, and red.

Halogen

- 41** Halogen lamp assembly, reflector and lens choice of six lens colors: amber, blue, clear, din blue, green and red. Clear lens can be specified with optional inserted half lenses. Available in amber, blue, and red.
- 41BZ** Halogen lamp assembly, bezel, reflector and lens choice of six lens colors: amber, blue, clear, din blue, green and red. Clear lens can be specified with optional inserted half lenses. Available in amber, blue, and red.

Scene Lighting

- 41-08** Halogen lamp assembly, reflector and clear lens with an eight degree scene light filter.
- 41-12** Halogen lamp assembly, reflector and clear lens with a twelve degree scene light filter.
- 41-15** Halogen lamp assembly, reflector and clear lens with a fifteen degree scene light filter.
- 41-26** Halogen lamp assembly, reflector and clear lens with a twenty-six degree scene light filter.
- 41Z08** Halogen lamp assembly, reflector, bezel and clear lens with an eight degree scene light filter.
- 41Z12** Halogen lamp assembly, reflector, bezel and clear lens with a twelve degree scene light filter.
- 41Z15** Halogen lamp assembly, reflector, bezel and clear lens with a fifteen degree scene light filter.
- 41Z26** Halogen lamp assembly, reflector, bezel and clear lens with a twenty-six degree scene light filter.

KKK-A-1822E

- 42** Halogen lamp assembly (S95285, 65W Transverse), reflector and lens choice of three lens colors: amber, clear and red.
- 42BZ** Halogen lamp assembly (S95285, 65W Transverse), bezel, reflector and lens choice of three lens colors: amber, clear and red.

Case Products

- 40K** Case of ten model 40 strobe light heads, all of the same color
- 40BZK** Case of ten model 40 strobe light heads with bezels, all of the same color
- 41K** Case of ten model 41 halogen light heads, all of the same color
- 41BZK** Case of ten model 41 halogen light heads with bezels, all of the same color
- 41-08K** Case of ten model 41-08 halogen scene light modules.
- 41-12K** Case of ten model 41-12 halogen scene light modules.
- 41-15K** Case of ten model 41-15 halogen scene light modules.
- 41-26K** Case of ten model 41-26 halogen scene light modules.
- 41Z08K** Case of ten model 41Z08 halogen scene light modules with bezel.
- 41Z12K** Case of ten model 41Z12 halogen scene light modules with bezel.
- 41Z15K** Case of ten model 41Z15 halogen scene light modules with bezel.
- 41Z26K** Case of ten model 41Z26 halogen scene light modules with bezel.
- 41BZK** Case of ten model 41 halogen light heads with bezels, all of the same color
- 41-08K** Case of ten model 41-08 halogen scene light modules.
- 41-12K** Case of ten model 41-12 halogen scene light modules.
- 41-15K** Case of ten model 41-15 halogen scene light modules.
- 41-26K** Case of ten model 41-26 halogen scene light modules.
- 41Z08K** Case of ten model 41Z08 halogen scene light modules with bezel.
- 41Z12K** Case of ten model 41Z12 halogen scene light modules with bezel.
- 41Z15K** Case of ten model 41Z15 halogen scene light modules with bezel.
- 41Z26K** Case of ten model 41Z26 halogen light heads, all the same color.
- 42K** Case of ten model 42 KKK-A-1822E halogen light heads, all of the same color.
- 42BZK** Case of ten model 42 KKK-A-1822E halogen light heads with bezels, all of the same color.

Upgrades: CA upgrade to 55 watt twist lock bulb from 50 watt for 41, 41BZ, 41K, 41BZK.

WARRANTY

This product was tested and found to be operational at the time of manufacture. Provided this product is installed and operated in accordance with the manufacturer's recommendations, Public Safety Equipment guarantees all strobe reflector assemblies and all other parts and components, for a period of 1 year from the date of purchase or delivery, whichever is later. Units demonstrated to be defective within the warranty period will be repaired or replaced at the factory service center at no cost.

Use of a lamp or other electrical load of a wattage higher than installed or recommended by the factory, or use of inappropriate or inadequate wiring or circuit protection causes this warranty to become void. Failure or destruction of the product resulting from abuse or unusual use and/or accidents is not covered by this warranty. Use of non-PSE components and assemblies may cause damage to the system and/or personal injury, and voids all warranties on PSE systems and components.

PSE shall in no way be liable for other damages including consequential, indirect or special damages whether loss is due to negligence or breach of warranty.

PSE MAKES NO OTHER EXPRESS OR IMPLIED WARRANTY INCLUDING, WITHOUT LIMITATION, WARRANTIES OF FITNESS OR MERCHANTABILITY, WITH RESPECT TO THIS PRODUCT.

PRODUCT RETURNS

In order to provide you with faster service, if you are going to return a product for repair or replacement*, please contact our factory to obtain a Return Goods Authorization Number (RGA number) before you ship the product to Code 3, Inc. Write the RGA number clearly on the package near the mailing label. Be sure you use sufficient packing materials to avoid damage to the product being returned while in transit.

*Code 3, Inc. reserves the right to repair or replace product at its discretion. Code 3, Inc. assumes no responsibility or liability for expenses incurred for the removal and/or reinstallation of products requiring service and/or repair.

NEED HELP? Call our Technical Assistance Hotline - (314) 996-2800

Code 3, Inc., a subsidiary of
Public Safety Equipment, Inc.

CODE 3[®]
PUBLIC SAFETY EQUIPMENT, INC.

Code 3, Inc.
10986 N. Warson Road
St. Louis, Missouri 63114-2029—USA
www.code3pse.com