

INSTALLATION & OPERATION MANUAL

MODEL 430™

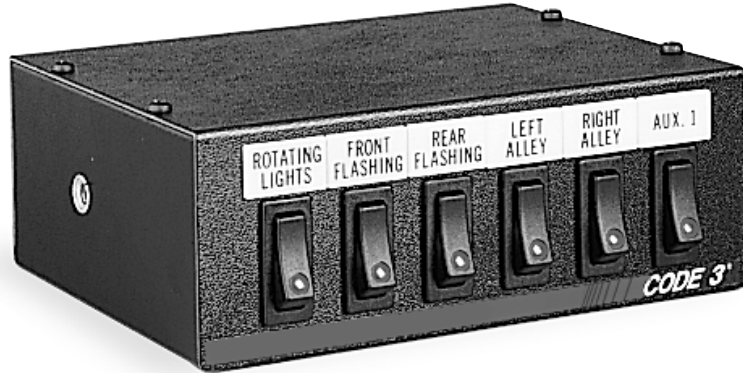

Code 3, Inc., a subsidiary of
Public Safety Equipment, Inc.

CODE 3®
PUBLIC SAFETY EQUIPMENT, INC.

Model 430™ SWITCH CONTROL

Contents:

Introduction	2
Safety First.....	3
Unpacking & Pre-Installation	3
Installation	4
Wiring	5
Parts List	6
Warranty	8

IMPORTANT:

Read all instructions and warnings before installing and using.

INSTALLER: *This manual must be delivered to the end user of this equipment.*

Introduction

The Switch Box switch control panel is designed to accommodate six rocker type switches, which are used to control various vehicle mounted devices. Six legend inserts are installed above the switches as shown in figure 1 and 2. Six additional legend inserts are included as part of the accessory kit packed with the switch module. A thermal lock out type circuit breaker, rated at 40 amps, protects the rotating light circuit (#1). The circuit of one load current is rated at 40 amps. The other circuits (2 through 6) are protected by automotive blade type fuses rated at 20 amperes.

The switch module is designed to be installed in a vehicle mounting surface to mate with other devices of the same width.

It can be installed on top of TSD style panels, trunion mount, and many other types of the same width. It may be used with various models of electronic sirens with the hardware included in the accessory kit, and secured to the mounting surface with the bracket included with the electronic siren.

Sizes, ratings and switches: the switches are a rugged unit and rated at 20 amperes @ 12 VDC. The panel's dimensions are 2 3/16" x 6 1/16" x 5 7/8" (including fuses). Overall weight of the unit is 2 pounds.

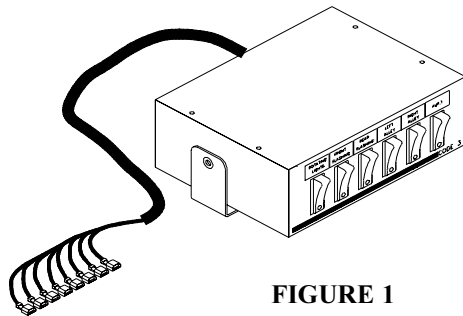

FIGURE 1



WARNING!

The use of this or any warning device does not insure that all drivers can or will observe or react to an emergency warning signal. Never take the right-of-way for granted. It is your responsibility to be sure you can proceed safely before entering an intersection, driving against traffic, responding at a high rate of speed, or walking on or around traffic lanes. The effectiveness of this warning device is highly dependent upon correct mounting and wiring. Read and follow the manufacturer's instructions before installing or using this device. The vehicle operator should insure daily that all features of the device operate correctly. In use, the vehicle operator should insure the projection of the warning signal is not blocked by vehicle components (i.e.: open trunks or compartment doors), people, vehicles, or other obstructions.

This equipment is intended for use by authorized personnel only. It is the user's responsibility to understand and obey all laws regarding emergency warning devices. The user should check all applicable city, state and federal laws and regulations.

Public Safety Equipment, Inc., assumes no liability for any loss resulting from the use of this warning device.

Proper installation is vital to the performance of this warning device and the safe operation of the emergency vehicle. It is important to recognize that the operator of the emergency vehicle is under psychological and physiological stress caused by the emergency situation. The warning device should be installed in such a manner as to: A) Not reduce the output performance of the system, B) Place the controls within convenient reach of the operator so that he can operate the system without losing eye contact with the roadway.

Emergency warning devices often require high electrical voltages and/or currents. Properly protect and use caution around live electrical connections. Grounding or shorting of electrical connections can cause high current arcing, which can cause personal injury and/or severe vehicle damage, including fire. Incandescent lamps are extremely hot, allow to cool completely before attempting to remove.

Any electronic device may create or be affected by electromagnetic interference. After installation of any electronic device operate all equipment simultaneously to insure that operation is free of interference. Never power emergency warning equipment from the same circuit or share the same grounding circuit with radio communication equipment.

PROPER INSTALLATION COMBINED WITH OPERATOR TRAINING IN THE PROPER USE OF EMERGENCY WARNING DEVICES IS ESSENTIAL TO INSURE THE SAFETY OF EMERGENCY PERSONNEL AND THE PUBLIC.

Safety First

Installers should keep in mind the importance of safe installation to protect the lives of those who may depend upon this equipment. Please read all instructions supplied with this equipment. Listed below are some other important safety instructions to follow:

To properly install the equipment described in this instruction sheet: you must have a good understanding of automotive electrical procedures and systems, along with proficiency in the installation and use of safety warning equipment.

Locate the switch module so the vehicle and controls can be operated safely under all driving conditions.

When drilling into a vehicle structure, be sure that both sides of the surface are clear of anything that could be damaged.

Keep these instructions in a safe place and refer to them when maintaining and/or reinstalling the product.

Failure to follow all safety precautions and instructions may result in property damage, serious injury, or death to you or others.

Unpacking & Pre-installation

Carefully remove the Switch Control from the shipping carton and place on a flat surface, taking care not to damage the wire cable coming out of the back of control box. Examine the unit for transit damage, dented cover, ect.. If convenient, you may wish to bench test the unit before installing. Before applying voltage to the bar, be sure you have read and understand the wiring instructions on page 5.

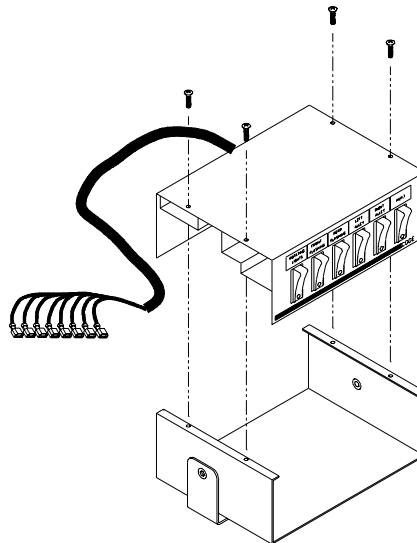

FIGURE 2

Installation



WARNING!

All devices should be mounted in accordance with the manufacturer's instructions and securely fasten to vehicle elements of sufficient strength to withstand the forces applied to the device. Driver and/or passenger air bags (SRS) will affect the way equipment should be mounted. This device should be mounted by permanent installation and within the zones specified by the vehicle manufacturer, if any. Any device mounted in the deployment area of an air bag will damage or reduce the effectiveness of the air bag and may damage or dislodge the device. Installer must be sure that this device, its mounting hardware and electrical supply wiring does not interfere with the air bag or the SRS wiring or sensors. Front or rear grille/bumper placement must avoid interference with SRS sensors. Mounting the unit inside the vehicle by a method other than the permanent installation is not recommended as unit may become dislodged during swerving, sudden braking, or collision. Failure to follow instructions can result in personal injury.

To install the Switch Box follow the installation instructions. There are several ways you may install this unit, but if it is installed with the TSD trunion mounting bracket, you will need to follow the instructions provided for the "CO" series brackets.

If you choose to mount this unit by a bail bracket (not provided), then follow the instructions that come with our bail brackets.

The Switch Box may be mounted on top of or below a siren system. If this is your choice, then follow the instructions below:

- 1) Select a mounting location which allows the vehicle and all controls to be operated safely under all driving conditions.
- 2) Choose an adequately ventilated area. Never install near heat ducts or totally enclosed areas.
- 3) Arrange the bottom of the switch control unit so that it is even with the siren face module. Fasten the two units together with trunion mounts or brackets (not provided) from both sides. You may need to remove the switch control for the housing. If this is the case, it will require the removal of four phillips head screws located on top of the switch control housing.

4) Secure the case with 1/4" - 20 x 5/8" hex head screws and 1/4" split lockwasher (provided in kit). Do not tighten securely until a proper angle is positioned for safe operator visibility.

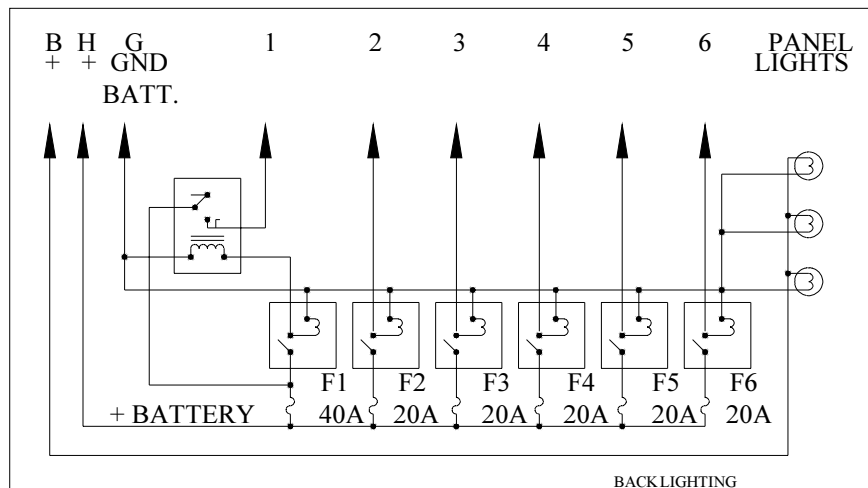

WIRING DIAGRAM

FIGURE 3

5) Tilt the unit to the desired position and tighten the 1/4" - 20 x 3/8" hex head screws.

6) Use the mounting bracket as a templet and position for two hole by marking the position with a scribe. Drill holes for positioning the mounting bracket.

CAUTION: When drilling holes in any part of the vehicle, make sure that both sides of the surface are clear of parts that could be damaged; such as brake lines, electrical wiring, fuel lines, or other vital parts of the vehicle.

7) Drill two 1/4" diameter holes at the position marked.

8) Secure the mounting bracket in place. Make sure all positions are tight and screws secured in place.

NOTE: Many other locations may be of better choice for your operation. If other locations are selected, use every precautionary measure to safely install to prevent damage to the vehicle.

Wiring



WARNING!

Larger wires and tight connections will provide longer service life for components. For high current wires it is highly recommended that terminal blocks or soldered connections be used with shrink tubing to protect the connections. Do not use insulation displacement connectors (e.g. 3M® Scotchlock type connectors). Route wiring using grommets and sealant when passing through compartment walls. Minimize the number of splices to reduce voltage drop. High ambient temperatures (e.g. underhood) will significantly reduce the current carrying capacity of wires, fuses, and circuit breakers. Use "SXL" type wire in engine compartment. All wiring should conform to the minimum wire size and other recommendations of the manufacturer and be protected from moving parts and hot surfaces. Looms, grommets, cable ties, and similar installation hardware should be used to anchor and protect all wiring.

Fuses or circuit breakers should be located as close to the power takeoff points as possible and properly sized to protect the wiring and devices.

Particular attention should be paid to the location and method of making electrical connections and splices to protect these points from corrosion and loss of conductivity. Ground terminations should only be made to substantial chassis components, preferably directly to the vehicle battery.

The user should install a fuse sized to approximately 125% of the maximum Amp capacity in the supply line to protect against short circuits. For example, a 30 Amp fuse should carry a maximum of 24 Amps. **DO NOT USE 1/4" DIAMETER GLASS FUSES AS THEY ARE NOT SUITABLE FOR CONTINUOUS DUTY IN SIZES ABOVE 15 AMPS.** Circuit breakers are very sensitive to high temperatures and will "false trip" when mounted in hot environments or operated close to their capacity.

Figure 2 illustrates the correlation of tagged wires to a corresponding operation. Example: Switch one (starting from left to right) controls the electronic operation of the wire tagged as #1.

Insulated male terminals, which mate with the female terminals on the switch module wiring harness, have been included in the accessory kit to facilitate installation. These terminals should be installed on the end of the lead wire which will mate with the wiring harness lead wire. Use yellow terminals for 10-12 AWG wire and pink terminals for 18-22 AWG wire.

NOTE: When using the insulated terminals, insure that all crimps are secure and that the male/female terminals slip into each other and not over each other.

To properly wire the switch module, see the wiring diagram shown in figure 3 and perform the following procedures:

1) Use 12 AWG wire and connect leads "1" through "6" to the applicable accessory load. Remember: lead "1" corresponds to switch "1", lead "2" to switch "2", and so on.

2) Use 18 AWG wire and connect the ground (earth) lead "G" to a reliable ground (earth). Each switched device must be grounded with a separate ground (earth) wire.

3) Use 18 AWG wire and connect the backlighting circuit lead "B" to the accessory terminal of the ignition switch or the vehicle instrument light circuit.

4) Power for the switch module may be obtained from a vehicle power distribution center (TSD part number D1X1F-PD90) or by a 60, 80, or 100 amp master circuit breaker (call TSD for part number required). We recommend that all circuits be protected by fuses or circuit breakers. Installation of a power distribution center or master circuit breaker should be placed near the battery. Use 8 AWG wire and connect the power distribution center. If power is obtained in the engine compartment, a hole will probably have to be drilled into the vehicle firewall. Place a grommet or similar device in the hole to protect the wire (S) against damage from rough edges.

CAUTION: When drilling holes in any part of any of the vehicle, ensure that both sides of the surface are clear of parts that could be damaged: such as brake lines, electrical wiring, fuel lines, or any other vital part of the vehicle.

Parts List

<u>Description</u>	<u>Qty.</u>
1/4" - 20x5/8" bolts	2
1/4" lock washer	2
wire ties	2
insulated 1/4" male terminals (yellow)	7
insulated 1/4" male terminals (pink)	2
legend inserts, (TAKE DOWN, GRILLE LIGHTS, DECK LIGHTS, STROBE,AUX., WIGWAG, FRT/REAR FLASHER, (CENTER & SWEEPS))	8

NOTES

WARRANTY

This product was tested and found to be operational at the time of manufacture. Provided this product is installed and operated in accordance with the manufacturer's recommendations, Public Safety Equipment guarantees all parts and components except the lamps for a period of 1 year from the date of purchase or delivery, whichever is later. Units demonstrated to be defective within the warranty period will be repaired or replaced at the factory service center at no cost.

Use of a lamp or other electrical load of a wattage higher than installed or recommended by the factory, or use of inappropriate or inadequate wiring or circuit protection causes this warranty to become void. Failure or destruction of the product resulting from abuse or unusual use and/or accidents is not covered by this warranty.

PSE shall in no way be liable for other damages including consequential, indirect or special damages whether loss is due to negligence or breach of warranty.

PSE MAKES NO OTHER EXPRESS OR IMPLIED WARRANTY INCLUDING, WITHOUT LIMITATION, WARRANTIES OF FITNESS OR MERCHANTABILITY, WITH RESPECT TO THIS PRODUCT.

PRODUCT RETURNS

If a product must be returned for repair or replacement*, please contact our factory to obtain a Return Goods Authorization Number (RGA number) before you ship the product to Code 3, Inc. Write the RGA number clearly on the package near the mailing label. Be sure you use sufficient packing materials to avoid damage to the product being returned while in transit.

*Code 3, Inc. reserves the right to repair or replace at its discretion. Code 3, Inc. assumes no responsibility or liability for expenses incurred for the removal and/or reinstallation of products requiring service and/or repair.; nor for the packaging, handling, and shipping; nor for the handling of products return to sender after the service has been rendered.

Public Safety Equipment, Inc.
10986 N. Warson Road
St. Louis, Missouri 63114-2029—USA
Ph. (314) 426-2700 Fax (314) 426-1337
www.code3pse.com

Wiring & Installation Guide

415 Series
Rocker Switch
Control Panels



Code 3, Inc., a subsidiary of
Public Safety Equipment, Inc.

CODE 3[®]
PUBLIC SAFETY EQUIPMENT, INC.

RockerPak™

Contents:

DESCRIPTION	PAGE
GENERAL INSTRUCTIONS	2
MODEL 415F	2
MODEL 415PO	2
MODEL 415PR	2
MODEL 415PS	3
MODEL 415T	3
STINGRAY HOOK-UP	3
PARTS AND SWITCHES	5
WIRE REQUIREMENTS	5
MOUNTING WITH SIREN	6
PTO HOOK-UP	6

The Code 3[®] RockerPak Series Lighting Control is a reliable and versatile unit with options that allow customized switch packages. The variety of final products is too great to be shown here in its entirety, but factory wiring makes the installation similar to the following examples in most cases.

General Instructions

1. Determine whether your control unit should be wired from the vehicle's battery or ignition circuitry, depending on the need for security and/or total access.
2. See the hook-up details for your model(s) as shown below. If you have a non-standard model, use the hook-up for the model having the same switch in the position illustrated.
3. Use #10 A.W.G. wire feed +(POS)12-volt supply to circuit breaker or fuse, then to switch unit. Circuit protection should be rated at 125% of the total load. Units with factory installed circuit breakers or fuse stacks may be straight wired without additional protection.
4. Units with Legend Backlighting may be hooked up as provided if you choose to operate the system from the ignition circuit. If you plan to operate with the switches always live, carefully cut the single red feed line to the backlighting light bulbs and use a butt-splice connector to provide power from the ignition circuit to prevent battery discharge. Remove the cut off end to prevent short circuits.
5. IMPORTANT: You will save time and protect the switches from damage by carefully aligning the male and female spade connectors before inserting. Use free hand on the rocker switch face to oppose insertion force.
6. Connect from vehicle chassis to switch unit ground (black wire) using #18 A.W.G. wire.
7. Connect each switch to the appropriate device using recommended wire sizes from the table on page 5, with fuses rated at 125% of each individual wire load. Do not fuse higher than the switch rating.

Models 415F, 415PR and 415PO

Use for any control with DPST switch (40 amps) in this position

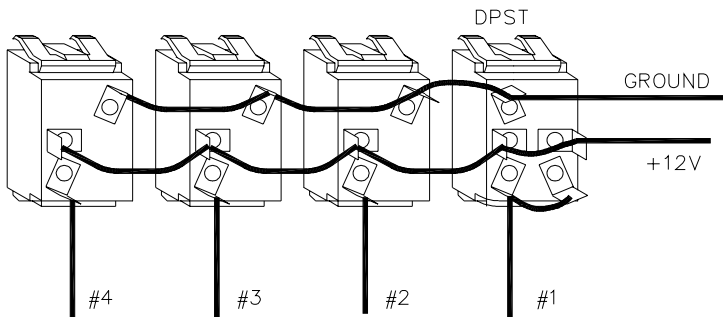

Models 415PS

Use this hook-up for any control having StringRay™ switching circuits.

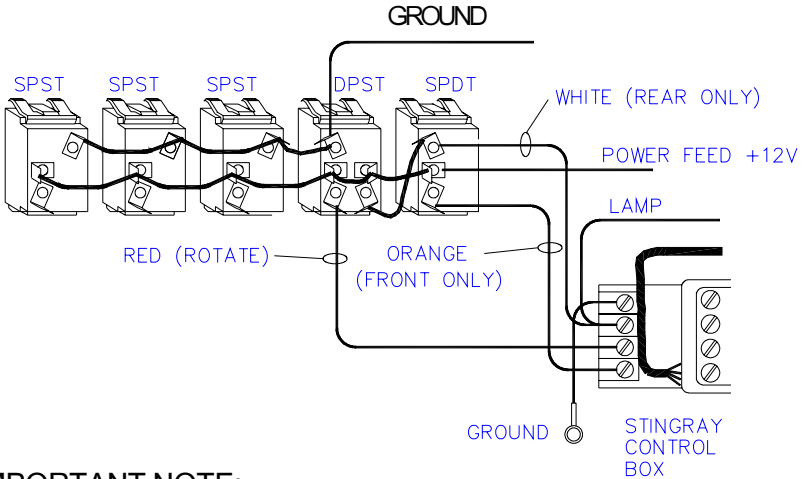

IMPORTANT NOTE:

The STINGRAY and ROTATE switches are wired together to provide the unique operational features of the StingRay oscillating signal. These switches may be activated at the same time; however ROTATE overrides STINGRAY R (Rear only). STINGRAY F (Front only) overrides ROTATE and does not operate unless ROTATE is also activated. The ROTATE switch will be lighted whenever the warning lights are lit.

Model 415T and all models with Circuit Breakers

Use this hook-up (as shown on right) for any control furnished with circuit breakers. See page 6 for PTO bracket installation.

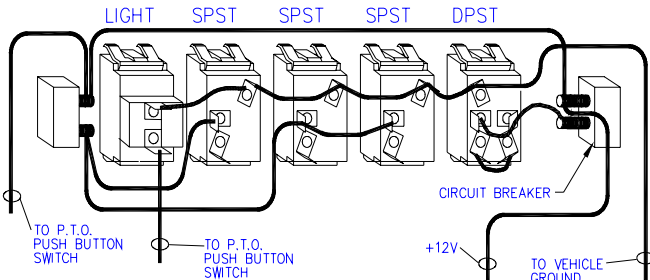

Individual Switches Wiring & Hook-up

Rear view of switches- -top is up.

Lighted SPST
P/N T02811

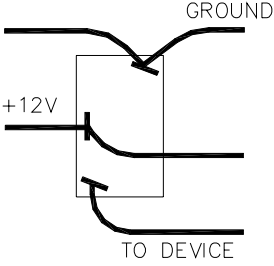

Lighted SPDT
P/N T02812

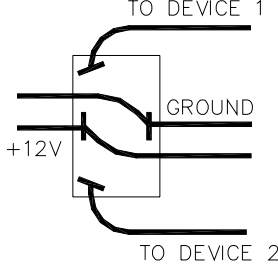

Lighted DPST
P/N T02821

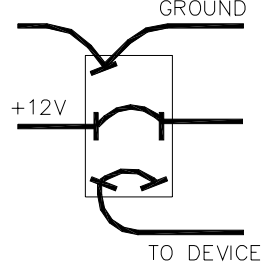

Lighted Progressive
P/N T02824

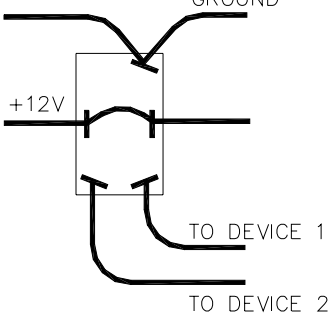

Non-Lighted SPST
Momentary
P/N T02813

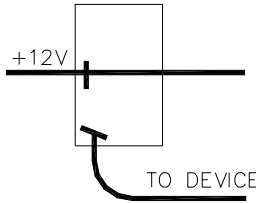

Non-Lighted SPDT
Momentary
P/N T02815

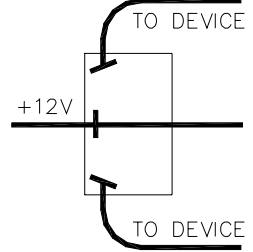

Non-Lighted DPDT
Radio Rebroadcast
P/N T02823

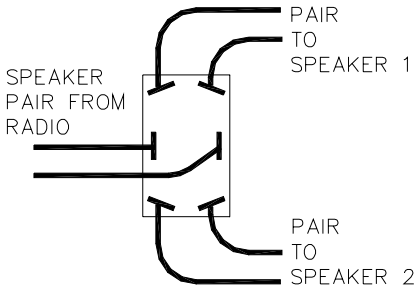

Fuse Stack
P/N S38033

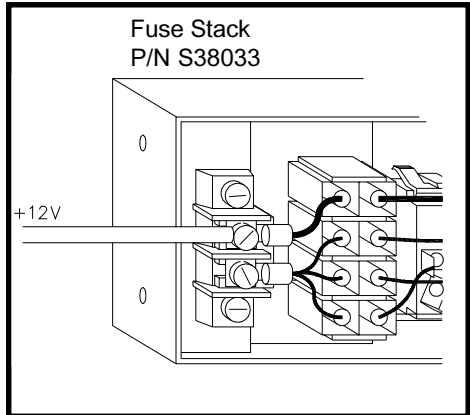

RECOMMENDED MINIMUM WIRE SIZES

BASED ON 15-FOOT WIRE RUN

AMP DRAW	MIN. WIRE SIZE
Below 5	#18 AWG
5-8	#16 AWG
9-13	#14 AWG
14-21	#12 AWG
22-36	#10 AWG

NOTE: Larger wires and tight connections will provide longer service life for switches and improve lighting performance. High ambient temperatures (e.g. under hood) will significantly reduce the current carrying capacity of wires, fuses and circuit breakers.

PARTS AND SWITCHES

- SPST — Single Pole, Single Throw switch; controls a single circuit.
 SPDT — Single Pole, Double Throw switch; controls either one or two circuits.
 DPST — Double Pole, Single Throw switch; high amperage single circuit.
 DPDT — Double Pole, Double Throw switch; for radio rebroadcast.
 Radio Rebroadcast — Transfers radio messages to siren speaker.
 Momentary — Remains active only while held, springs back to OFF.
 Progressive — Turns two functions on or off in a set sequence.

NUMBER	TYPE	APPLICATION	POSITIONS	LIGHTED	RATING
T02811	SPST	Single circuit	OFF-ON	YES	20 amp
T02812	SPDT	Alternate circ.	ON-OFF-ON	YES	20 amp
T02813	SPST	Momentary	OFF-MomON	NO	8 amp
T02814	Blank	Fills hole	—	NO	—
T02815	SPDT	Moment/Moment	ON-OFF-ON	NO	8 amp
T02820	—	Red Indicator Light	—	YES	-
T02821	DPST	High Amperage	OFF-ON	YES	40 amp
T02822	SPDT	StringRay switch	ON-OFF-ON	NO	20 amp
T02823	DPDT	Radio Rebroadcast	ON-ON	NO	8 amp
T02824	PROG	Progressive	OFF-ON-ON	YES	20 amp
T02838	Auto Reset	Circuit Breaker	—	-	40 amp
T02871	Push Button	Switch (415T only)	OFF-ON	NO	1 amp
T02872	Actuator	Disk (PTO unit only)			
S38033	Fuse Stack	(Factory Upgrade—cannot be field installed)			
S38046	Backlighting	Assembly (Bulbs with wires only)			
S38049	Backlighting	Assembly (Complete)			
S38093	Floor-mounting	Bracket, PTO Control			
S25013	RockerPak	Mounting Bracket (2 required)			

Parts not listed should be purchased locally

Suggested Mounting with V-Con[®] Siren

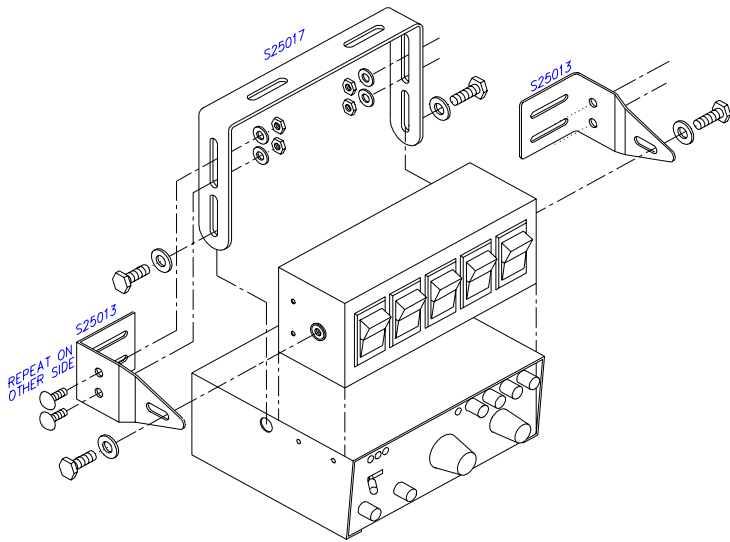

PTO Mounting Bracket Hook-up

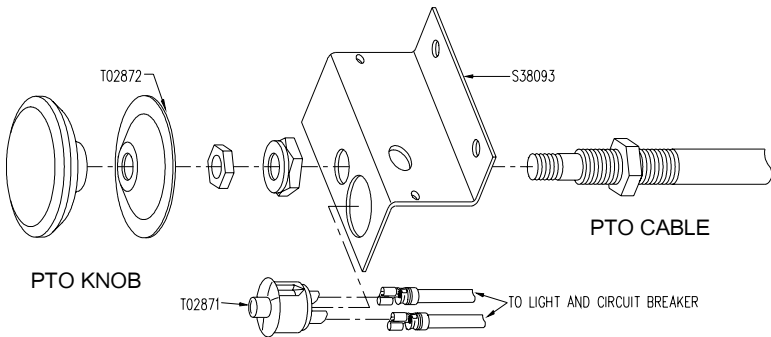

NOTES

WARRANTY

Code 3, Inc.'s emergency devices are tested and found to be operational at the time of manufacture. Provided they are installed and operated in accordance with manufacturer's recommendations, Code 3, Inc. guarantees all parts and components except the lamps to a period of 1 year (unless otherwise expressed) from the date of purchase or delivery, whichever is later. Units demonstrated to be defective within the warranty period will be repaired or replaced at the factory service center at no cost.

Use of lamp or other electrical load of a wattage higher than installed or recommended by the factory, or use of inappropriate or inadequate wiring or circuit protection causes this warranty to become void. Failure or destruction of the product resulting from abuse or unusual use and/or accidents is not covered by this warranty. Code 3, Inc. shall in no way be liable for other damages including consequential, indirect or special damages whether loss is due to negligence or breach of warranty.

CODE 3, INC. MAKES NO OTHER EXPRESS OR IMPLIED WARRANTY INCLUDING, WITHOUT LIMITATION, WARRANTIES OF FITNESS OR MERCHANTABILITY, WITH RESPECT TO THIS PRODUCT.

PRODUCT RETURNS

If a product must be returned for repair or replacement*, please contact our factory to obtain a Return Goods Authorization Number (RGA number) before you ship the product to Code 3, Inc. Write the RGA number clearly on the package near the mailing label. Be sure you use sufficient packing materials to avoid damage to the product being returned while in transit.

*Code 3, Inc. reserves the right to repair or replace at its discretion. Code 3, Inc. assumes no responsibility or liability for expenses incurred for the removal and/or reinstallation of products requiring service and/or repair; nor for the packaging, handling, and shipping; nor for the handling of products return to sender after the service has been rendered.

Public Safety Equipment, Inc.
10986 N. Warson Road
St. Louis, Missouri 63114-2029—USA
Ph. (314) 426-2700 Fax (314) 426-1337

Code 3,® Inc., a subsidiary of
Public Safety Equipment, Inc.

Revision C, 11/00 - Instruction Book Part No.T02887
©2000 Public Safety Equipment, Inc. Printed in USA

INSTALLATION & OPERATION MANUAL

MODEL 416/426
SWITCHBOX

Code 3, Inc., a subsidiary of
Public Safety Equipment, Inc.

CODE 3
PUBLIC SAFETY EQUIPMENT, INC.

Introduction

The 416 Switchbox is a 6 switch control center without circuit breakers. The model 426 is the same 6 switch control center protected by 3 circuit breakers. The 426 also offers backlighting as standard equipment. Backlighting is optional on the 416.

Procedure

Wiring Instructions:

- 1) The installer needs to first determine the current load in amps of each of the devices to be switched by the Switchbox.
- 2) Connect the devices to the desired switch, noting the current limitations of each switch and group of switches.
- 3) An 8 gauge wire should be run from the Red 8 gauge Switchbox input wire to a user supplied fuse, then to the (+) side of the battery, the alternator, or the stud on the battery side of the solenoid. The user supplied fuse should be located as close to the battery as possible and sized to 125% of the total load carried by the Switchbox (i.e.: if the total load carried is 40 amps; $40 \text{ amps} \times 125\% = 50 \text{ amp fuse}$). A circuit breaker is not recommended here, they are very sensitive to high ambient temperatures and will false trip

when mounted in hot environments or operated close to their capacity. Do not use 1/4" dia. glass fuses as they are not suitable for continuous duty in sizes above 15 amps.

- 4) Connect the black wire to vehicle chassis (earth).



WARNING!

Larger wires and tight connections (crimp connectors perform poorly over time) will provide longer service life for components. It is highly recommended that terminal blocks or soldered connections be used with shrink tubing to protect the connections. Do not use insulation displacement connectors (e.g. 3M® Scotchlock type connectors). Route wiring using grommets and sealant when passing through compartment walls. Minimize the number of splices to reduce voltage drop. High ambient temperatures (e.g. under hood) will significantly reduce the current carrying capacity of wires, fuses, and circuit breakers. Use "SXL" type wire in engine compartments.

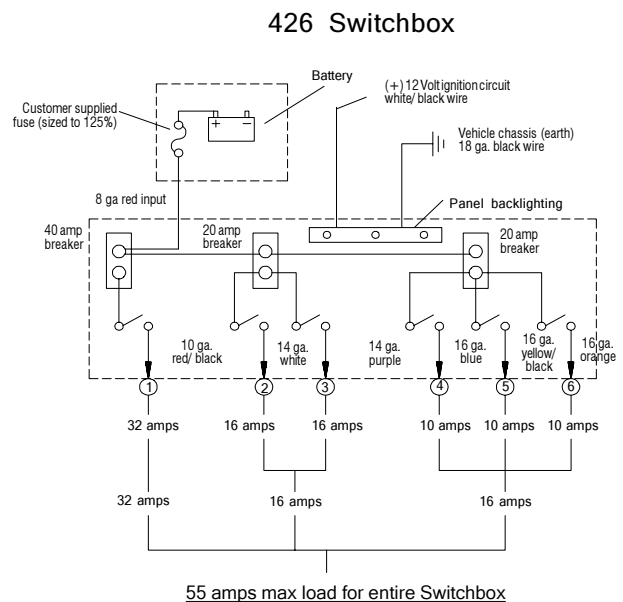
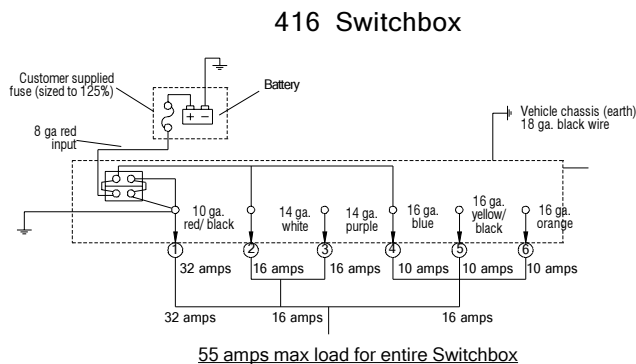

IMPORTANT:

Read all instructions and warnings before installing and using.

INSTALLER: *This manual must be delivered to the end user of this equipment.*

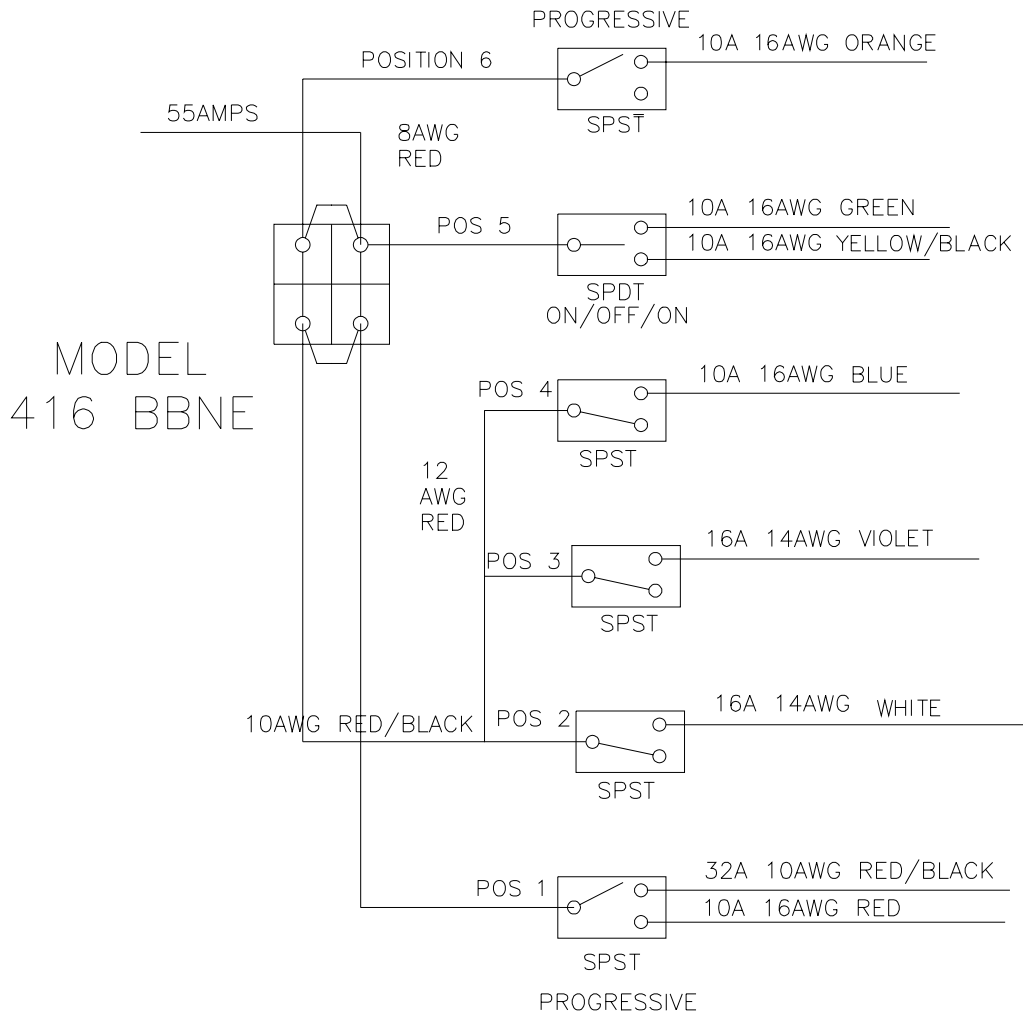

WARNING!

The use of this or any warning device does not insure that all drivers can or will observe or react to an emergency warning signal. Never take the right-of-way for granted. It is your responsibility to be sure you can proceed safely before entering an intersection, driving against traffic, responding at a high rate of speed, or walking on or around traffic lanes. The effectiveness of this warning device is highly dependent upon correct mounting and wiring. Read and follow the manufacturer's instructions before installing or using this device. The vehicle operator should insure daily that all features of the device operate correctly. In use, the vehicle operator should insure the projection of the warning signal is not blocked by vehicle components (i.e.: open trunks or compartment doors), people, vehicles, or other obstructions.

This equipment is intended for use by authorized personnel only. It is the user's responsibility to understand and obey all laws regarding emergency warning devices. The user should check all applicable city, state and federal laws and regulations.

Public Safety Equipment, Inc., assumes no liability for any loss resulting from the use of this warning device.

NOTES

WARRANTY

This product was tested and found to be operational at the time of manufacture. Provided this product is installed and operated in accordance with the manufacturer's recommendations, Public Safety Equipment guarantees all parts and components except the lamps for a period of 1 year from the date of purchase or delivery, whichever is later. Units demonstrated to be defective within the warranty period will be repaired or replaced by the factory or at a factory authorized service center at no cost.

Use of a lamp or other electrical load of a wattage higher than installed or recommended by the factory causes this warranty to become void. Failure or destruction of the product resulting from abuse or unusual use and/or accidents is not covered by this warranty.

PSE shall in no way be liable for other damages including consequential, indirect or special damages whether loss is due to negligence or breach of warranty.

PSE MAKES NO OTHER EXPRESS OR IMPLIED WARRANTY INCLUDING, WITHOUT LIMITATION, WARRANTIES OF FITNESS OR MERCHANTABILITY, WITH RESPECT TO THIS PRODUCT.

PRODUCT RETURNS

In order to provide you with faster service, if you are going to return a product for repair or replacement*, please contact our factory to obtain a Return Goods Authorization Number (RGA number) before you ship the product to PSE. Write the RGA number clearly on the package near the mailing label. Be sure you use sufficient packing materials to avoid damage to the product being returned while in transit.

*PSE reserves the right to repair or replace product at its discretion. PSE assumes no responsibility or liability for expenses incurred for the removal and/or reinstallation of products requiring service and/or repair.

Public Safety Equipment, Inc.
10986 N. Warson Road
St. Louis, Missouri 63114-2029—USA
Ph. (314) 426-2700 Fax (314) 426-1337
www.code3pse.com