

INSTALLATION & OPERATION MANUAL

LED PERIMETER,
STOP/TURN/TAIL
SERIES 45, 65, 85

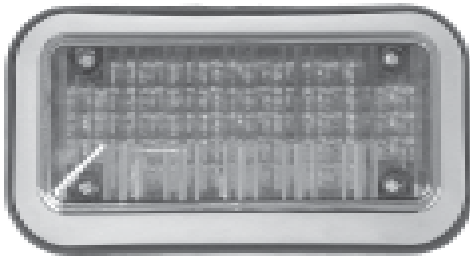

Code 3,® Inc., a subsidiary of
Public Safety Equipment, Inc.

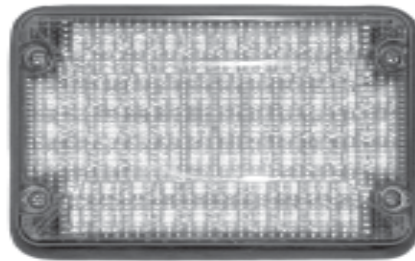

SERIES 45, 65, 85

LED PERIMETER, STOP/TURN/TAIL

Contents:

Introduction	2
Unpacking & Pre-Installation	2
Mounting Options	3
Installation & Wiring	3-6
Flash Pattern Selection	7
Power Requirements	7-8
Parts & Exploded View	8
Maintenance	9
Options	9
Warranty	12

IMPORTANT:

Read all instructions and warnings before installing and using.

INSTALLER:

This manual must be delivered to the end user of this equipment.

Introduction

The 45/65/85 Series LED Perimeter Light Heads are designed for the emergency vehicle market. The light heads are to be connected directly to +12 or +24 VDC systems for independent flashing or through electro-mechanical or solid state flasher units. These light heads with their unique optics are designed for full, optimized signals at all angles.

Models 45STR and 65STR (Red Stop-Turn-Tail); 45STA and 65STA (Amber Turn) meet the requirements for Stop-Turn-Tail lamps of Federal Motor Vehicle Safety Standard No. 108 and SAE specifications J2040, J2261 and J593. These units are to be installed only on the rear of the vehicle. The units are to be connected to the stop/tail, turn signal, and reverse light circuitry of the vehicle.

Consisting of an LED base unit, lens, o-ring, gasket, optional bezel and mounting screws, these units are easy to install.



WARNING!

The use of this or any warning device does not insure that all drivers can or will observe or react to an emergency warning signal. Never take the right-of-way for granted. It is your responsibility to be sure you can proceed safely before entering an intersection, driving against traffic, responding at a high rate of speed, or walking on or around traffic lanes.

The effectiveness of this warning device is highly dependent upon correct mounting and wiring. Read and follow the manufacturer's instructions before installing or using this device. The vehicle operator should insure daily that all features of the device operate correctly. In use, the vehicle operator should insure the projection of the warning signal is not blocked by vehicle components (i.e.: open trunks or compartment doors), people, vehicles, or other obstructions. This equipment is intended for use by authorized personnel only. It is the user's responsibility to understand and obey all laws regarding emergency warning devices. The user should check all applicable city, state and federal laws and regulations.

Public Safety Equipment, Inc., assumes no liability for any loss resulting from the use of this warning device.

Proper installation is vital to the performance of this warning device and the safe operation of the emergency vehicle. It is important to recognize that the operator of the emergency vehicle is under psychological and physiological stress caused by the emergency situation. The warning device should be installed in such a manner as to: A) Not reduce the output performance of the system, B) Place the controls within convenient reach of the operator so that he can operate the system without losing eye contact with the roadway.

Emergency warning devices often require high electrical voltages and/or currents. Properly protect and use caution around live electrical connections. Grounding or shorting of electrical connections can cause high current arcing, which can cause personal injury and/or severe vehicle damage, including fire. Wait 10 minutes after turning off the power from system before touching any internal components. Always wear hand and eye protection when handling electrical components.

PROPER INSTALLATION COMBINED WITH OPERATOR TRAINING IN THE PROPER USE OF EMERGENCY WARNING DEVICES IS ESSENTIAL TO INSURE THE SAFETY OF EMERGENCY PERSONNEL AND THE PUBLIC.

Unpacking and Pre-Installation

Carefully remove the light head from its protective packaging. Inspect the unit for transit damage. Report any damage to the carrier and keep the shipping carton. Verify the contents of the package (refer to Figures 4 & 5 on page 8).

Mounting Options

There are three mounting options for the LED base unit:

1. Attaching the LED base unit with high strength double-sided foam tape (customer supplied). This option minimizes the piercing of the vehicle by requiring only a center wire hole.
2. Attaching the LED base unit with four #10 x 3/4" sheet metal screws.
3. Attaching the LED base unit and lens together using four #6 x 1-1/2" sheet metal screws.

Options 1 and 2 allow removal of the outer lens without removing the base from the vehicle. Option 3 allows removal of the entire unit from the vehicle with the removal of only four screws.

Installation

1. Determine the mounting options to be used. Select the desired mounting location for the light head assembly. The installation must accommodate the base gaskets. Refer to Figure 1 for gasket dimensions. *Note: The gaskets are flexible. Do not use them for drill templates.*
2. Verify free clearance behind the mounting surface for wiring and fasteners.
3. Using the appropriate template (Figures 2-4) cut the center opening for the wiring and install a grommet (customer supplied). Use a drill bit sized for the appropriate thickness of the mounting surface and a #10 sheet metal screw for drilling the screw holes. For example: for aluminum alloy sheet metal .125" thick, a #23 (.154") drill size is recommended. *Note: If the unit is to be attached with very high bond tape instead of screws then the screw holes need not be drilled. Clean the mounting surfaces of the vehicle and the light head with isopropyl alcohol and dry thoroughly prior to attaching tape.*
4. Route the vehicle power wires and allow a minimum of 3 inches of slack to protrude from the center opening at each light head location. Use 18 AWG for wires up to 40 feet length, 16 AWG for wires up to 70 feet length.
5. Place the light head gasket (and bezel if used) over the light head location and run the vehicle power wire slack through the center opening of the gasket. Refer to Figures 5 & 6.
6. For Perimeter Lights refer to the section **Flash Pattern Selection** prior to finalizing the electrical connections. Prepare the vehicle power wires and the light head's wires with terminations of the customer's choice (not supplied). Waterproof connectors are recommended. Refer to the following table for appropriate wiring connections.

Code 3 LED Perimeter Light Models	Wire Function		
	Red	White	Black
Models 45, 65, 85 - Perimeter Configurations	+12 or +24	Program	Ground
45STR & 65STR - LED STT, Red	Stop or Turn	Tail	
45STA & 65STA - LED STT, Amber	Turn	none	

Connect the light head's black and red wires to the vehicle system's ground and positive (+12 or +24 VDC), respectively. **Note: For Perimeter Lights the white flash pattern selection wire must be protected from contact with the system ground to prevent inadvertent changes to the flash pattern. This can be accomplished by sealing or capping the end of the wire.**

7. At the power source end of the cable determine if the cable length is acceptable. If a shorter length is required, coil the cable and tie with an electrical tie.
8. Verify proper light head operation by supplying electrical power to the system wires at the power source end of the cable.
9. Verify that the O-ring is properly seated onto the LED base unit.
10. Push the assembled electrical connectors through the center opening and into the vehicle.
11. Push the LED base unit (and bezel if used) into the gasket. The LED base unit is symmetric and does not have a preferred top or bottom. Verify that the gasket (and bezel if used) is properly oriented. These parts are labeled with "TOP" and their part numbers at the top and have a drain slot at the bottom.

- 12. Mount the LED base unit and gasket (and bezel if used) using four #10 x 3/4" screws. Optionally the unit may be mounted with very high bond tape (customer supplied). If tape is used it should be attached to the base unit and the vehicle. Do not use tape to secure the gasket to either the LED base unit or the vehicle chassis. Follow the tape manufacturer's instructions to ensure proper adhesion.
- 13. Verify the "TOP" lens marking is on the top and install the lens using four screws. Two screw options are supplied: four #10 x 3/4" screws or four #6 x 1-1/2" screws. The #10 screws attach the lens to the LED base unit. The optional longer #6 screws go through the LED base unit and tap into the vehicle body. If the longer #6 screws are used then first drill an appropriate pilot hole into the vehicle body.

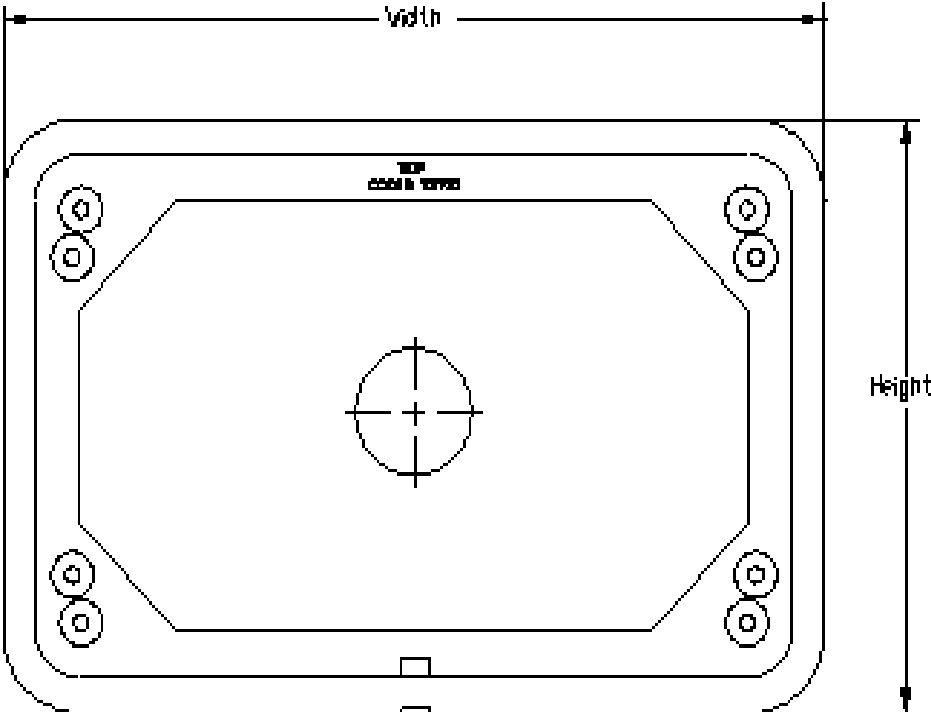

MODEL	WIDTH	HEIGHT
45	7.84	3.67
65	7.00	4.6
85	9.77	7.78
45BZ	9.18	5
65BZ	8.00	5.6
85BZ	11.1	9.11

FIGURE 1
 Gasket Dimensions
 (For Layout Purposes Only. Do Not Scale.)

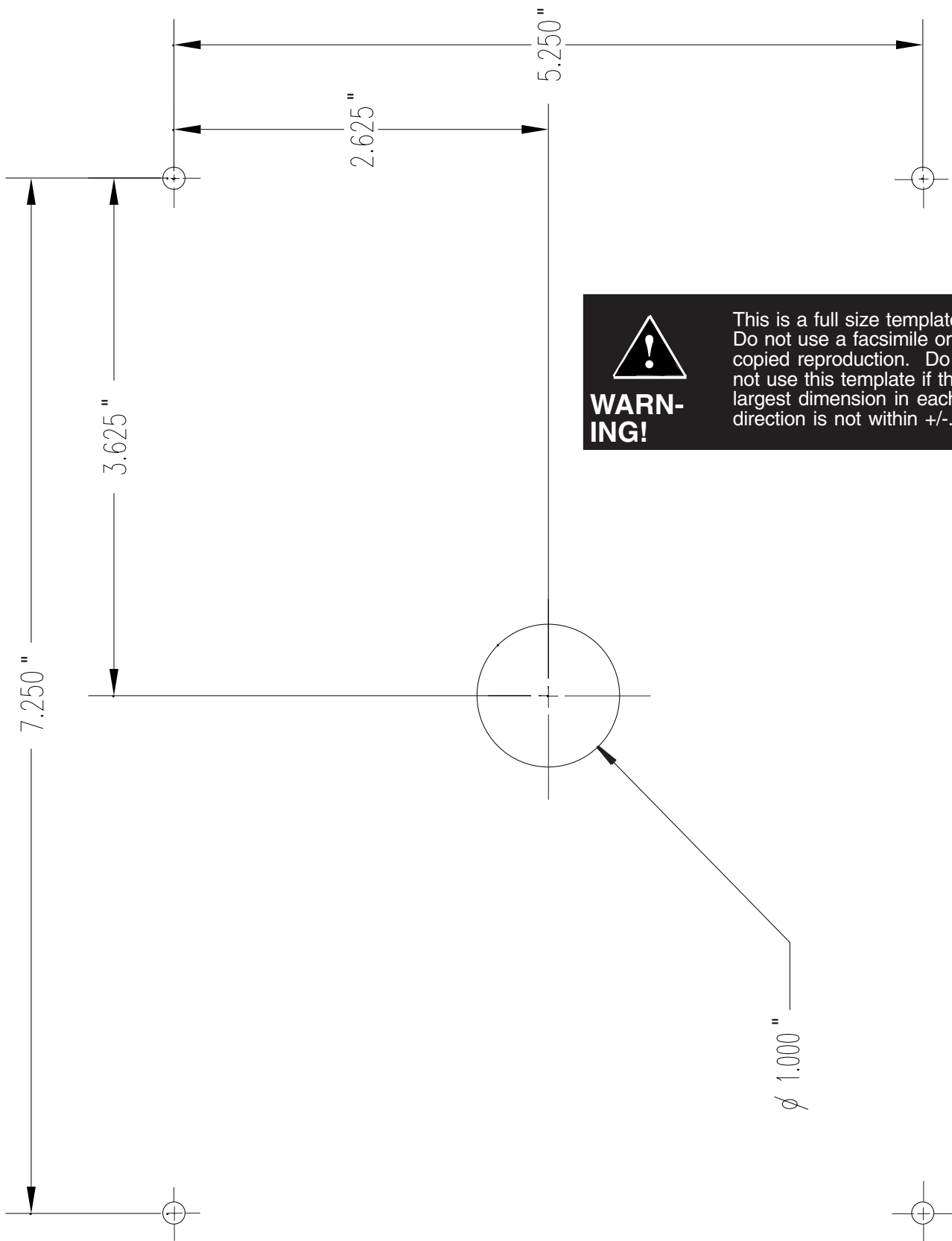

9x7 (Model 85)

FIGURE 2

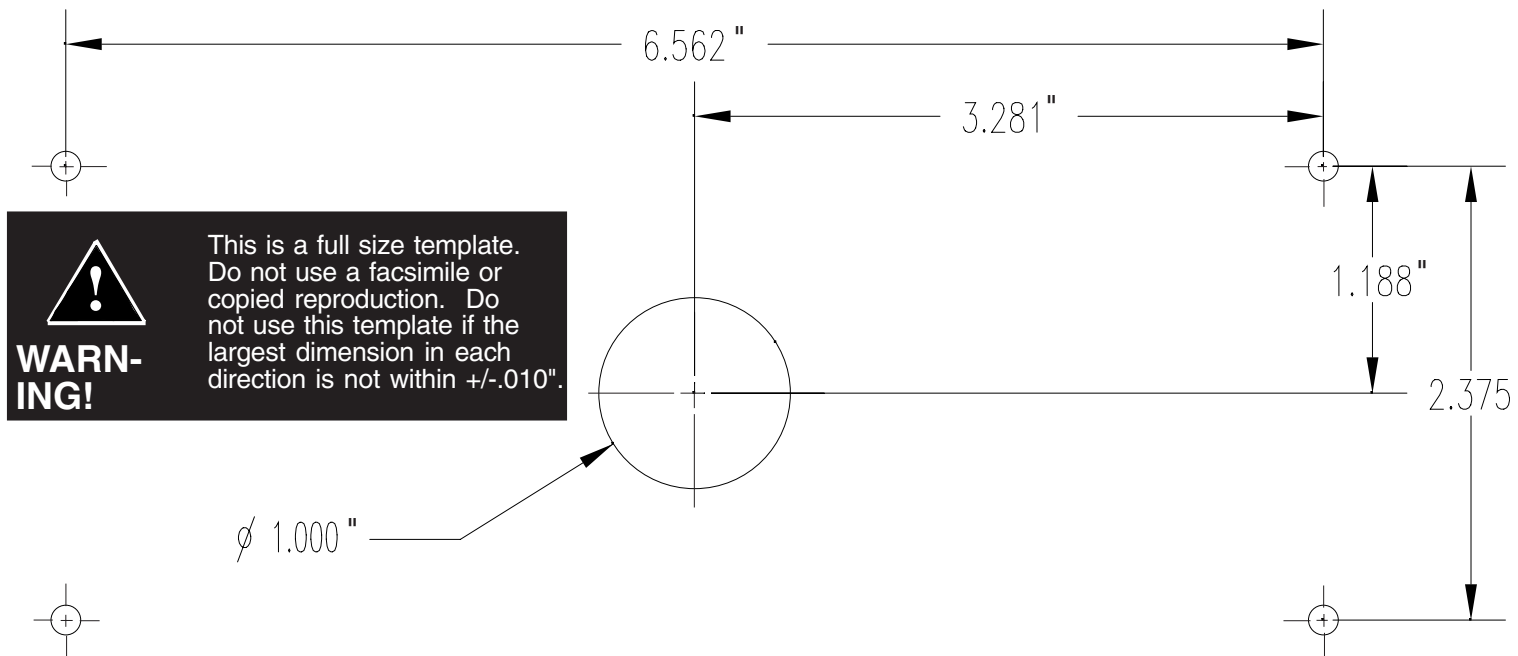

7x3 (Model 45)

FIGURE 3

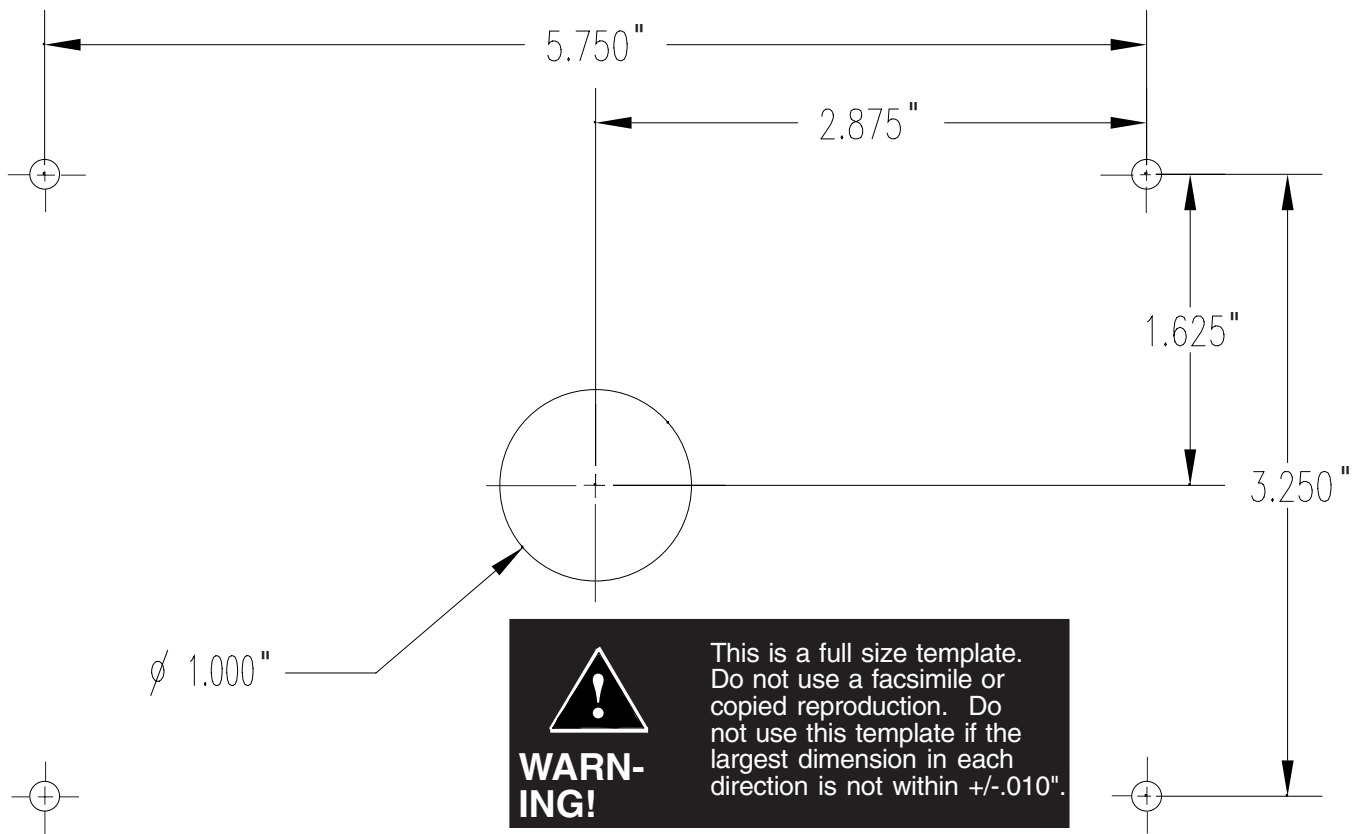

6x4 (Model 65)

FIGURE 4

Flash Pattern Selection

The LED Perimeter Lights are equipped with one steady burn and twenty flashing patterns *including ten alternating patterns, an exclusive feature of the Code 3 LED Perimeter Light*. All flash patterns are either 75 flashes per minute (FPM) or 150 FPM.

To select a different flash pattern, apply +12 or +24 VDC to the red wire and connect the black wire to the power supply ground. The unit will flash in whatever pattern was last set. Change the pattern by momentarily touching the white wire to the power supply ground. The flash pattern will change to the next pattern according to the following list:

Pattern Number	Description
-	Steady Burn
1	75 FPM Single
2	75 FPM, Alternating Sides
3	150 FPM Single
4	150 FPM Single, Alternating Sides
5	75 FPM Double
6	75 FPM Double, Alternating Sides
7	75 FPM Triple
8	75 FPM Triple, Alternating Sides
9	75 FPM Quad
10	75 FPM Quad, Alternating Sides
11	150 FPM Quad
12	150 FPM Quad, Alternating Sides
13	75 FPM Hi-Low-Low-Hi
14	75 FPM Hi-Low-Low-Hi, Alternating Sides
15	150 FPM Double
16	150 FPM Double, Alternating Sides
17	150 FPM Triple
18	150 FPM Triple, Alternating Sides
19	75 FPM Hi-Low-Hi
20	75 FPM Hi-Low-Hi, Alternating Sides

Continue to cycle through the various patterns until the desired pattern is selected. The unit will retain this pattern even when power is removed. ***Note: For Perimeter Lights the white flash pattern selection wire must be protected from contact with the system ground to prevent inadvertent changes to the flash pattern. This can be accomplished by sealing or capping the end of the wire.***

For units that are flashed with an external control system such as a multiplexer or a flasher unit, the heads should be set to steady burn. Note: Regardless of the location in the program in the flash pattern list, the unit can be forced to steady burn by permanently electrically tying the white wire to the black wire.

It is recommended that all heads be set to the desired pattern at a workbench prior to installation.

Power Requirements

The Code3 LED Perimeter Lights are designed to be long life, full signal, light weight and low current draw. The following table lists the number of LED's in each model and the average current draw for various conditions.

Code 3 LED Perimeter Light Models	Number of LED's	Average Current Draw, Amps			
		Steady Burn 13.8VDC	Flashing 13.8VDC	Steady Burn 24.0VDC	Flashing 24VDC
Model 45,45STA&45STR 7x3 Perimeter	62	1.0	0.5	0.5	0.3
Model 65, 6x4 Perimeter	76	1.0	0.5	0.5	0.3
Model 85, 9x7 Perimeter	124	1.5	0.8	0.8	0.4
65STR - 6x4, Red (Stop or Turn Config.)	54	0.7	0.4	0.4	0.2
65STR - 6x4, Red (Tail Configuration)		0.05	n/a	0.04	n/a
65STA - 6x4, Amber Turn	54	0.7	0.4	0.4	0.2

Parts & Exploded Views

Note: All of the components illustrated are for the 45 series. They are shown for reference only. The procedures outlined within are generic procedures and are for use in the 65 & 85 series as well.

Standard Unit, Figure 4	Bezeled Unit, Figure 5	1	2	3	4 *	5 *	6 *	7
Code 3 Model Number - Description	Code 3 Model Number - Description	Base	Lens	Lens O-Ring	Gasket	Bezel	Bezel Gasket	Bag of Screws
45R - LED Perim, 7x3, Red	45BZR - LED Perim, 7x3, Red, Bezel	--	T07891	T07925	T07919	T07916	T07922	T07928
45A - LED Perim, 7x3, Amber	45BZA - LED Perim, 7x3, Amber, Bezel	--	T07892					
45B - LED Perim, 7x3, Blue	45BZB - LED Perim, 7x3, Blue, Bezel	--	T07893					
45W - LED Perim, 7x3, White	45BZW - LED Perim, 7x3, White, Bezel	--	T07894					
45RB - LED Perim, 7x3, Red-Blue	45BZRB - LED Perim, 7x3, Red-Blue	--	T07894					
45RA - LED Perim, 7x3, Red-Amber	45BZRAW - LED Perim, 7x3, Red-Amber	--	T07894					
45RW - LED Perim, 7x3, Red-White	45BZRW - LED Perim, 7x3, Red-White	--	T07894					
45AW - LED Perim, 7x3, White-Amber	45BZAW - LED Perim, 7x3, White-Amber	--	T07894					
45STR - LED STT, 7x3, Red	45STBZR - LED STT, 7x3, Red	--	T07895					
45STA - LED Turn, 7x3, Amber	45STBZA - LED Turn, 7x3, Amber	--	T07896					
65R - LED Perim, 6x4, Red	65BZR - LED Perim, 6x4, Red, Bezel	--	T07901	T07926	T07920	T07917	T07923	
65A - LED Perim, 6x4, Amber	65BZA - LED Perim, 6x4, Amber, Bezel	--	T07902					
65B - LED Perim, 6x4, Blue	65BZB - LED Perim, 6x4, Blue, Bezel	--	T07903					
65W - LED Perim, 6x4, White	65BZW - LED Perim, 6x4, White, Bezel	--	T07904					
65RB - LED Perim, 6x4, Red-Blue	65BZRB - LED Perim, 6x4, Red-Blue	--	T07904					
65RA - LED Perim, 6x4, Red-Amber	65BZRAW - LED Perim, 6x4, Red-Amber	--	T07904					
65RW - LED Perim, 6x4, Red-White	65BZRW - LED Perim, 6x4, Red-White	--	T07904					
65AW - LED Perim, 6x4, Amber-White	65BZAW - LED Perim, 6x4, Amber-White	--	T07904					
65STR - LED STT, 6x4, Red	65STBZR - LED STT, 6x4, Red, Bezel	--	T07905					
65STA - LED Turn, 6x4, Amber	65STBZA - LED Turn, 6x4, Amber, Bezel	--	T07906					
85R - LED Perim, 9x7, Red	85BZR - LED Perim, 9x7, Red, Bezel	--	T07911	T07927	T07921	T07918	T07924	
85A - LED Perim, 9x7, Amber	85BZA - LED Perim, 9x7, Amber, Bezel	--	T07912					
85B - LED Perim, 9x7, Blue	85BZB - LED Perim, 9x7, Blue, Bezel	--	T07913					
85W - LED Perim, 9x7, White	85BZW - LED Perim, 9x7, White, Bezel	--	T07914					

- * Gasket, item 4, only used for Standard Units.
- Bezel, item 5, and Bezel Gasket, item 6, only used for Bezeled Units.
- Turn Arrow Insert T04580 only used with 65STA.

Maintenance

The lens is field removable for cleaning or replacement. Remove the lens by unscrewing the four mounting screws. Use mild detergent, warm water and a soft cloth to clean both surfaces of the lens. Use of any other chemicals may void product warranty. Thoroughly dry before reinstalling.

Because plastic scratches easily, cleaning is only recommended when necessary. Do not subject the lenses to car washes that use brushes as these will scratch the lenses. Do not use a pressure washer.

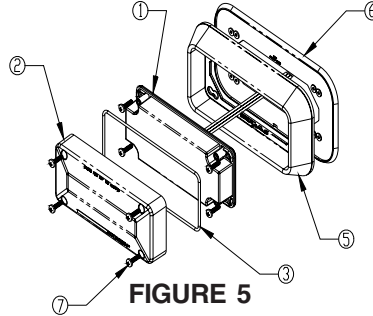
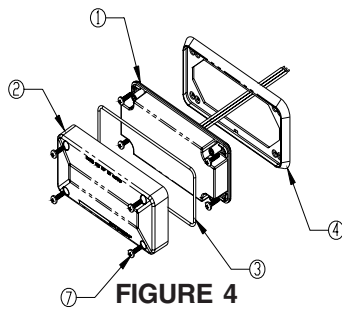

Case Products

Cases of ten units, all the same. Add suffix letter K to the model number. For example, 45BZRK is a case of ten LED perimeter lights, 7 X 3, Red, Bezel.

65F 4x6 LED for Headlamp Housing (See figure 6 below)

1. Slip (4) tinnerman clips onto the four corners of the lower mtg brkt #S89856
2. Attach the lens, gasket, and LED, to the mounting plate part #S95273.
3. Attach assembled LED assy to the lower mtg bracket with screws through the tinnerman clips.

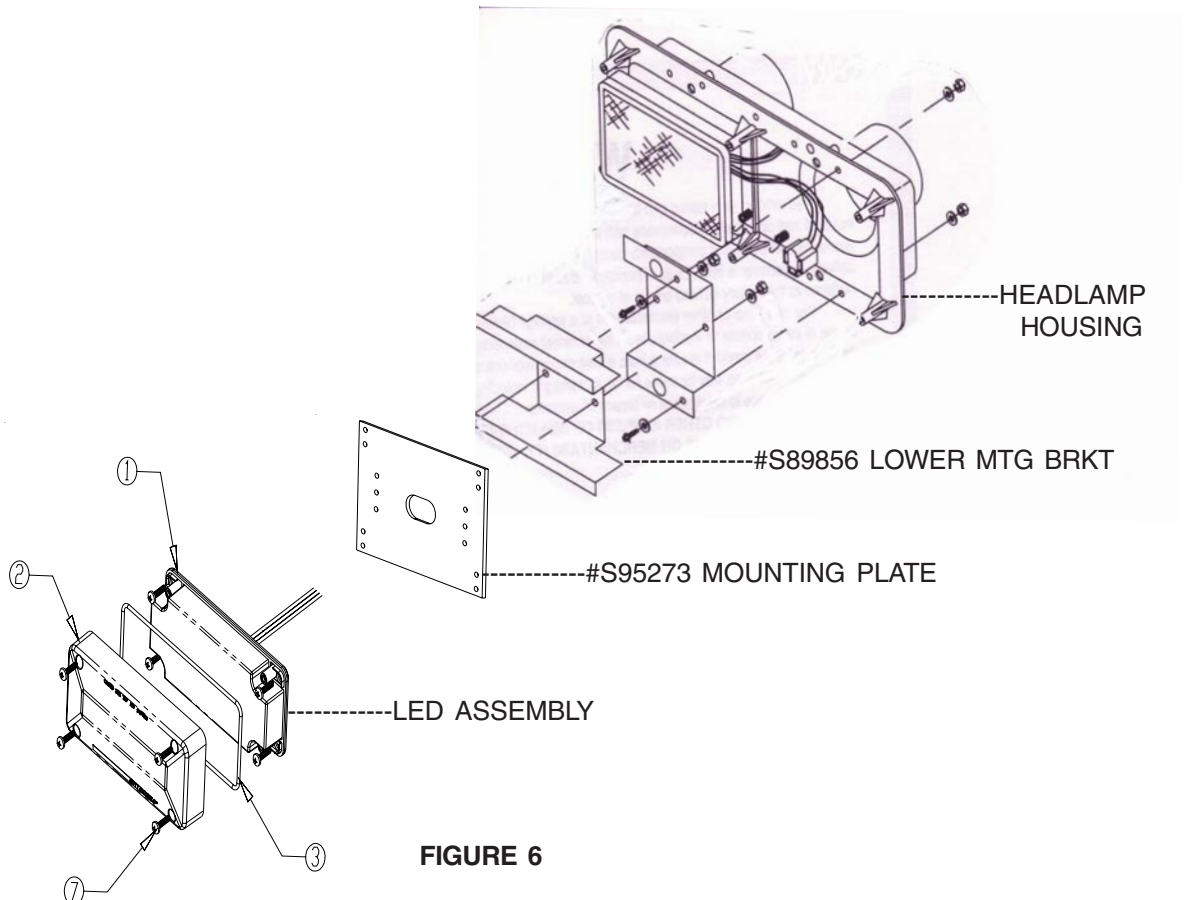
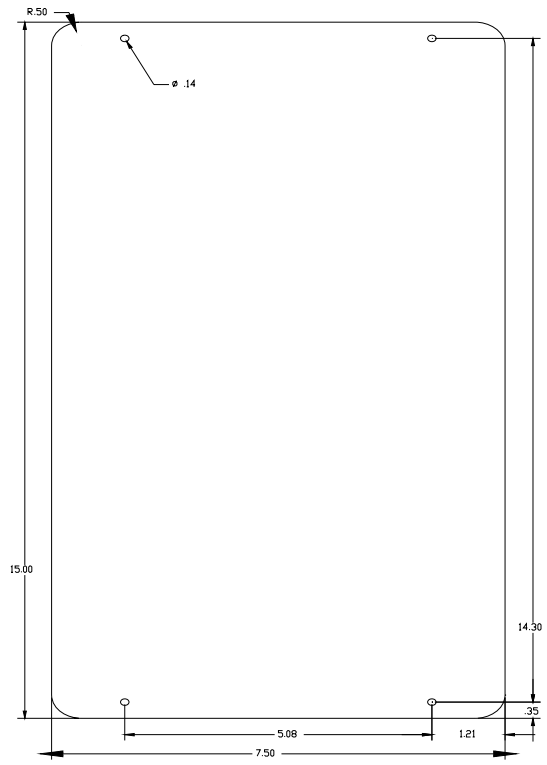
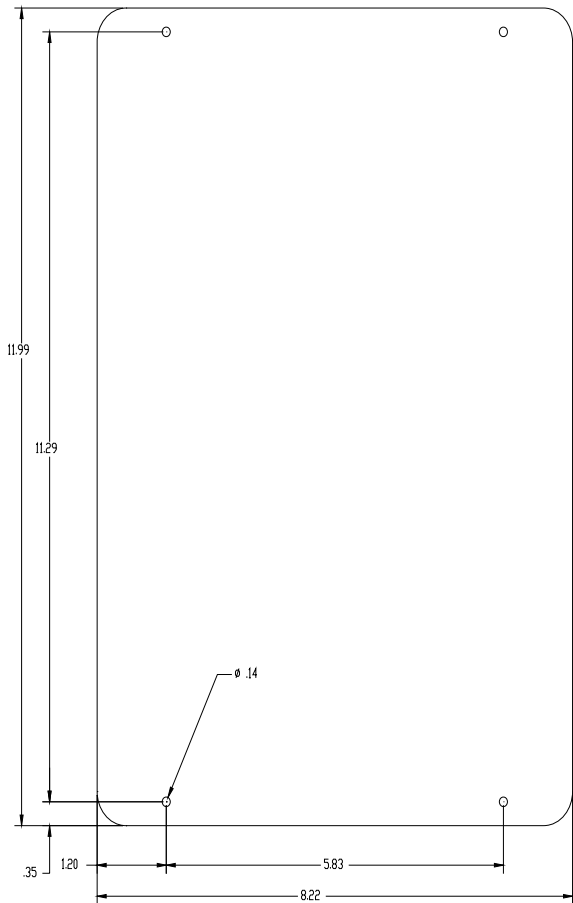

FIGURE 6



**MOUNTING DIMENSIONS FOR
65STK3 4X6 LED PERIMETER
TRIPLE STACK HOUSING**



**MOUNTING DIMENSIONS FOR
45STK3 3X7 LED PERIMETER
TRIPLE STACK HOUSING**

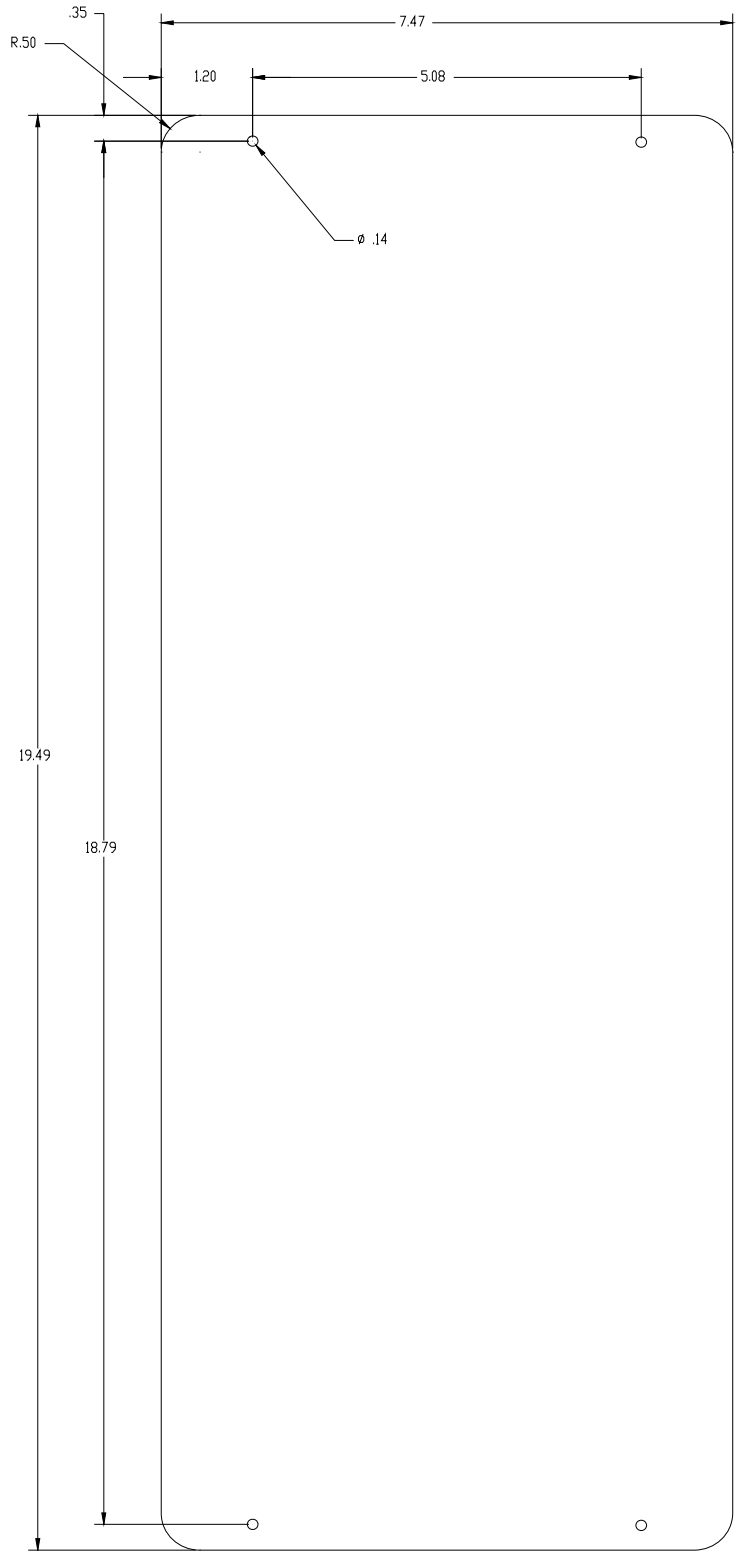

**MOUNTING DIMENSIONS FOR
65STK4 4X6 LED PERIMETER
QUAD STACK HOUSING**

NOTES:

WARRANTY

Code 3, Inc. L.E.D. emergency warning devices are designed to exceed all industry standards and are tested and found to be operational at the time of manufacture. Provided they are installed and operated in accordance with manufacturer's recommendations, Code 3, Inc. guarantees all parts and components to a period of 1 year and the LED base unit for 5 years from the date of purchase or delivery, whichever is later. LED emergency warning devices which do not meet industry standards, within the warranty period, will be repaired or replaced, at Code 3 Inc.'s option, at the factory service center.

Use of inappropriate or inadequate wiring or circuit protection causes this warranty to become void. Failure or destruction of the product resulting from abuse or unusual use and/or accidents is not covered by this warranty. Code 3, Inc. shall in no way be liable for other damages including consequential, indirect or special damages whether loss is due to negligence or breach of warranty.

CODE 3, INC. MAKES NO OTHER EXPRESS OR IMPLIED WARRANTY INCLUDING, WITHOUT LIMITATION, WARRANTIES OF FITNESS OR MERCHANTABILITY, WITH RESPECT TO THIS PRODUCT.

PRODUCT RETURNS

If a product must be returned for repair or replacement*, please contact our factory to obtain a Return Goods Authorization Number (RGA number) before you ship the product to Code 3, Inc. Write the RGA number clearly on the package near the mailing label. Be sure you use sufficient packing materials to avoid damage to the product being returned while in transit.

*Code 3, Inc. reserves the right to repair or replace at its discretion. Code 3, Inc. assumes no responsibility or liability for expenses incurred for the removal and /or reinstallation of products requiring service and/or repair.; nor for the packaging, handling, and shipping; nor for the handling of products return to sender after the service has been rendered.

PROBLEMS OR QUESTIONS? CALL OUR TECHNICAL ASSISTANCE HOTLINE (314) 996-2800

Code 3, ® Inc., a subsidiary of
Public Safety Equipment, Inc.

PUBLIC SAFETY EQUIPMENT, INC.

Code 3, Inc.
10986 N. Warson Road
St. Louis, Missouri 63114-2029—USA
Ph. (314) 426-2700
Fax (314) 426-1337
www.code3pse.com