

INSTALLATION & OPERATION MANUAL

CPS690
REMOTE STROBE
POWER
SUPPLY



CODE 3[®]
A PUBLIC SAFETY EQUIPMENT COMPANY

CPS690

REMOTE STROBE POWER SUPPLY

IMPORTANT: *Read all instructions and warnings before installing and using.*
INSTALLER: *This manual must be delivered to the end user of this equipment.*

Introduction

The CPS690 Series Remote Strobe Power Supply represents the latest in state-of-the-art strobe warning technology. The latest in MOSFET technology and advanced design provide efficient operation, meaning superior performance, reliability and long life. The use of intelligent microprocessor control allows the Model CPS690 series to offer more light pattern options and versatility than any other remote system available. The user may select Double, Triple, Quad, Five Flash or Cycle Flash Patterns. When connected to remote strobe heads, the CPS690 delivers the highest available level of emergency warning signals.

Standard Features

The CPS690 Remote Strobe Power Supply is available as a 4 strobe Hide-a-way kit as part number 490HCL. The 490HCL comes complete with a CPS690 power supply, four Hide-a-way strobe tubes and four 30' cables. Refer to CODE 3 manual T07715 for details on installation of the Hide-a-way strobe tubes. All MODEL CPS690 Remote Strobe Power Supplies have the the following features:

12 AND 24 VDC OPERATION

REVERSE POLARITY PROTECTED

EXTERNAL FUSE PROTECTION

User replaceable 15 AMP fuse.

OUTPUT SHORT CIRCUIT/FLASHTUBE FAILURE PROTECTION

Power supply will shut down when trying to flash any heads that have been shorted.

MULTIPLE USER SELECTABLE FLASH PATTERNS

User may select either Double Flash, Triple Flash, Quad Flash, Five Flash, or Cycle Flash patterns. See Flash Control Options Section, page 6.

SELECTABLE CONTROL OF OUTLET PAIRS

Allows user to select either alternating outlet sets 1-2, or 3+5- 4+6, or all outlets active (6 Head).

THIS POWER SUPPLY IS NFPA COMPLIANT WHEN USED IN QUAD OR FIVE FLASH MODES. SEE FIGURE F ON PAGE 8.

Specifications

OPERATING VOLTAGE: 10-30 VDC

POWER: 90 WATTS

ENERGY: 85 JOULES NOMINAL

STANDARD FLASH RATE: EACH STROBE LIGHT OUTLET 70 QUAD FLASHES/MIN.
ALTERNATING PAIRS 140 QUAD FLASHES/MIN.

POWER CONSUMPTION: 8.5 AMPS AVERAGE @ 12.8 VDC (HIGH POWER)



The use of this or any warning device does not insure that all drivers can or will observe or react to an emergency warning signal. Never take the right-of-way for granted. It is your responsibility to be sure you can proceed safely before entering an intersection, driving against traffic, responding at a high rate of speed, or walking on or around traffic lanes. The effectiveness of this warning device is highly dependent upon correct mounting and wiring. Read and follow the manufacturer's instructions before installing or using this device. The vehicle operator should insure daily that all features of the device operate correctly. In use, the vehicle operator should insure the projection of the warning signal is not blocked by vehicle components (i.e.: open trunks or compartment doors), people, vehicles, or other obstructions.

This equipment is intended for use by authorized personnel only. It is the user's responsibility to understand and obey all laws regarding emergency warning devices. The user should check all applicable city, state and federal laws and regulations.

Public Safety Equipment, Inc., assumes no liability for any loss resulting from the use of this warning device.

Proper installation is vital to the performance of this warning device and the safe operation of the emergency vehicle. It is important to recognize that the operator of the emergency vehicle is under psychological and physiological stress caused by the emergency situation. The warning device should be installed in such a manner as to: A) Not reduce the output performance of the system, B) Place the controls within convenient reach of the operator so that one can operate the system without losing eye contact with the roadway.

Emergency warning devices often require high electrical voltages and/or currents. Properly protect and use caution around live electrical connections. Grounding or shorting of electrical connections can cause high current arcing, which can cause personal injury and/or severe vehicle damage, including fire. Do not touch the strobe light tubes, the strobe light head assemblies or the strobe power supply while the system is in operation. Wait 10 minutes after turning off the power from system before touching any internal componentry.

PROPER INSTALLATION COMBINED WITH OPERATOR TRAINING IN THE PROPER USE OF EMERGENCY WARNING DEVICES IS ESSENTIAL TO INSURE THE SAFETY OF EMERGENCY PERSONNEL AND THE PUBLIC.

Unpacking and Pre-installation

Remove the power supply from the box and examine the unit for any transit damage. Report any damage to the carrier immediately. Inspect the supplied user parts kit, the 490HCL Hide-A-Way Strobe kit should contain:

- A. 1 Power/Control Wire Harness Assembly**
- B. 1 CPS690 Strobe Power Supply**
- C. 4 30 ft. cables**
- D. 4 Strobe Tube assemblies with connectors**
- E. 1 Parts Bag**
- F. 1 Installation Manual**

Installation and Mounting

1. First install the CPS690 strobe power supply in a protected location using the power supply itself as a template. THE POWER SUPPLY MUST BE MOUNTED TO A METAL SURFACE. Make sure all socket connectors are easily accessible.

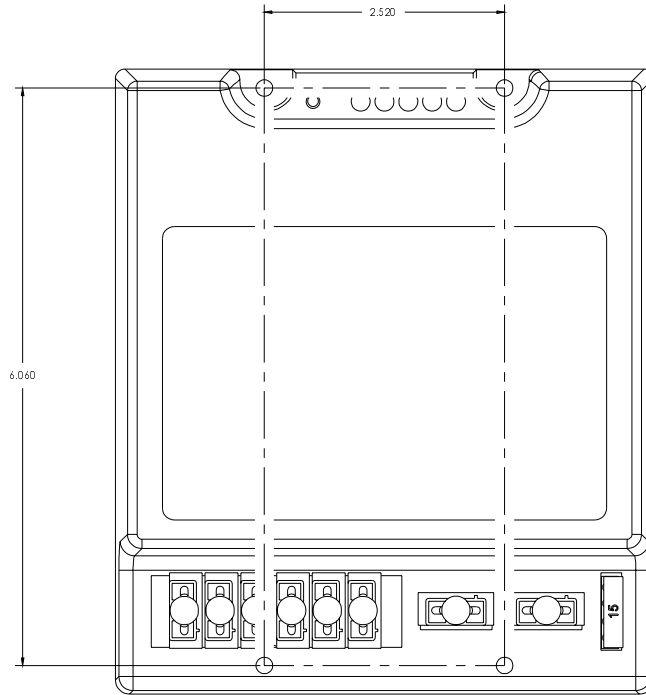

FIGURE A



WARNING!

The Model CPS690 Strobe Power Supply is NOT waterproof and should be located in an area protected from the weather and water.

Wiring

1. Install the strobe light heads in the desired locations.
2. String the 3-conductor cables between the lights and the power supply. Make sure the cable is secure along the chosen routing inside the vehicle to prevent it from damage by chafing or binding. Be sure to keep the cable away from engine hot spots.
3. Insert the pins on each end of the conductor cables into the AMP connectors. Each end of these cables has three pins factory crimped onto each of the three wires. See Figure B on next page for Pin Insertion order.

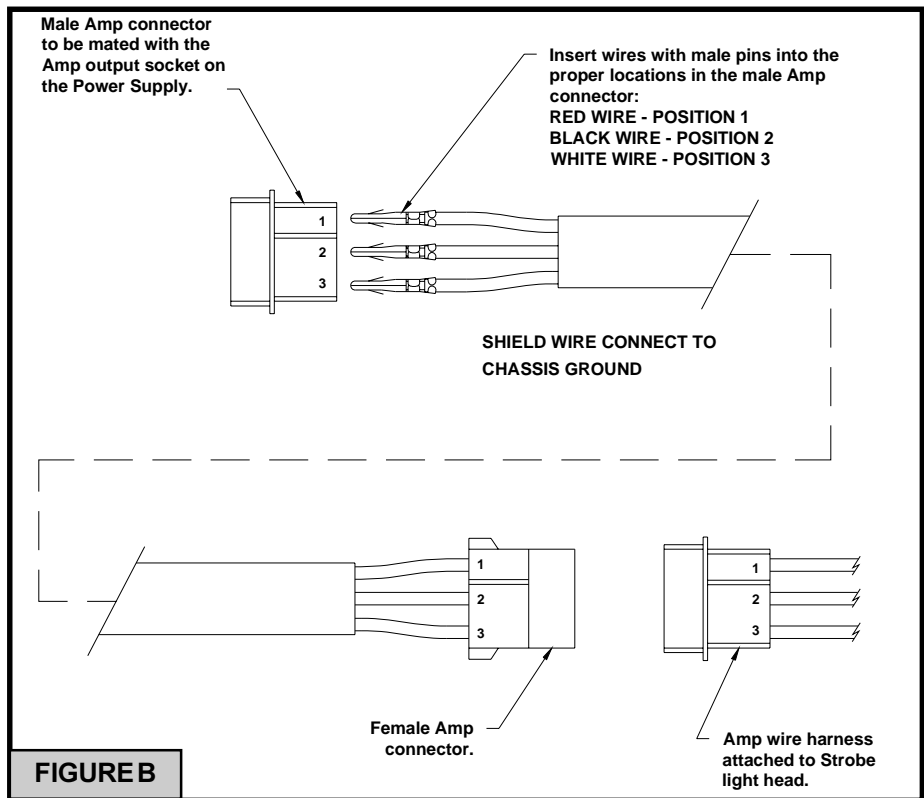

FIGURE B

NOTE: IT IS IMPORTANT TO FOLLOW THE CORRECT COLOR CODE WHEN INSERTING THE PINS INTO THE AMP 3 PIN CONNECTORS.

4. Connect the cables to the strobe light heads.

5. Next, plug the other end of the cable into the Light Head socket (output) on the CPS690 strobe power supply. The location of the cable for each light head attached to the CPS690 will be determined by the flash mode selected. (see figure E on page 6)

POWER/CONTROL WIRE HARNESS ASSEMBLY

The Power/Control wire harness assembly consists of two 3 pin AMP style connectors with: 1 red, 1 black, 1 violet, 1 yellow, 1 blue and 1 green (see figure C). The Power/Control harness assembly must be connected to the power/control socket(s) located on the CPS690 strobe light power supply. Use 18 gauge wire to extend the control harness wires to a customer supplied switch to complete the installation.

IMPORTANT: To extend the power (+) and ground (-) wires, use the following as a guide.

- 1 to 10 ft. use 16AWG wire
- 10 to 20 ft. use 14AWG wire
- 20 to 30 ft. use 12AWG wire
- 30 to 50 ft. use 10AWG wire

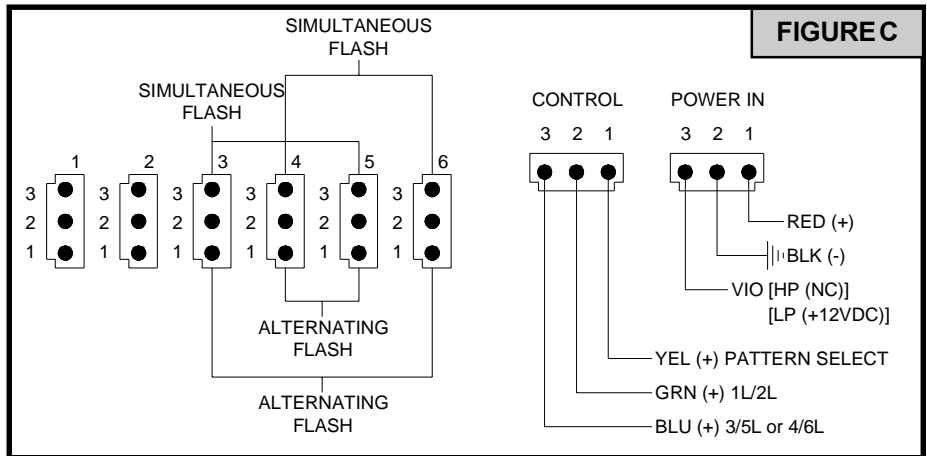

FIGURE C

1. Connect the Control wires from the Power/Control wire harness assembly to a switch or switches. To select one of the 12 different flash functions, simply press and release the pattern select switch until the desired pattern is selected (see Figure F). The flash pattern may also be selected remotely by the operator by connecting a Normally Open (NO) Momentary Push Button Switch to pin 1 (Yellow Wire) of the control connector. See Figure D for Control Switch connections. See Figure E for Control Wire combinations.

2. Connect Black wires to a reliable ground.(-)

3. Connect Red Power wires from the Power /Control wire harness assembly to the power source (+) through a switch and an in-line fuse (15A for 12V operation or 7.5A for 24V operation) for the desired operation per Figure D or Figure E.

CONTROL & POWER WIRING

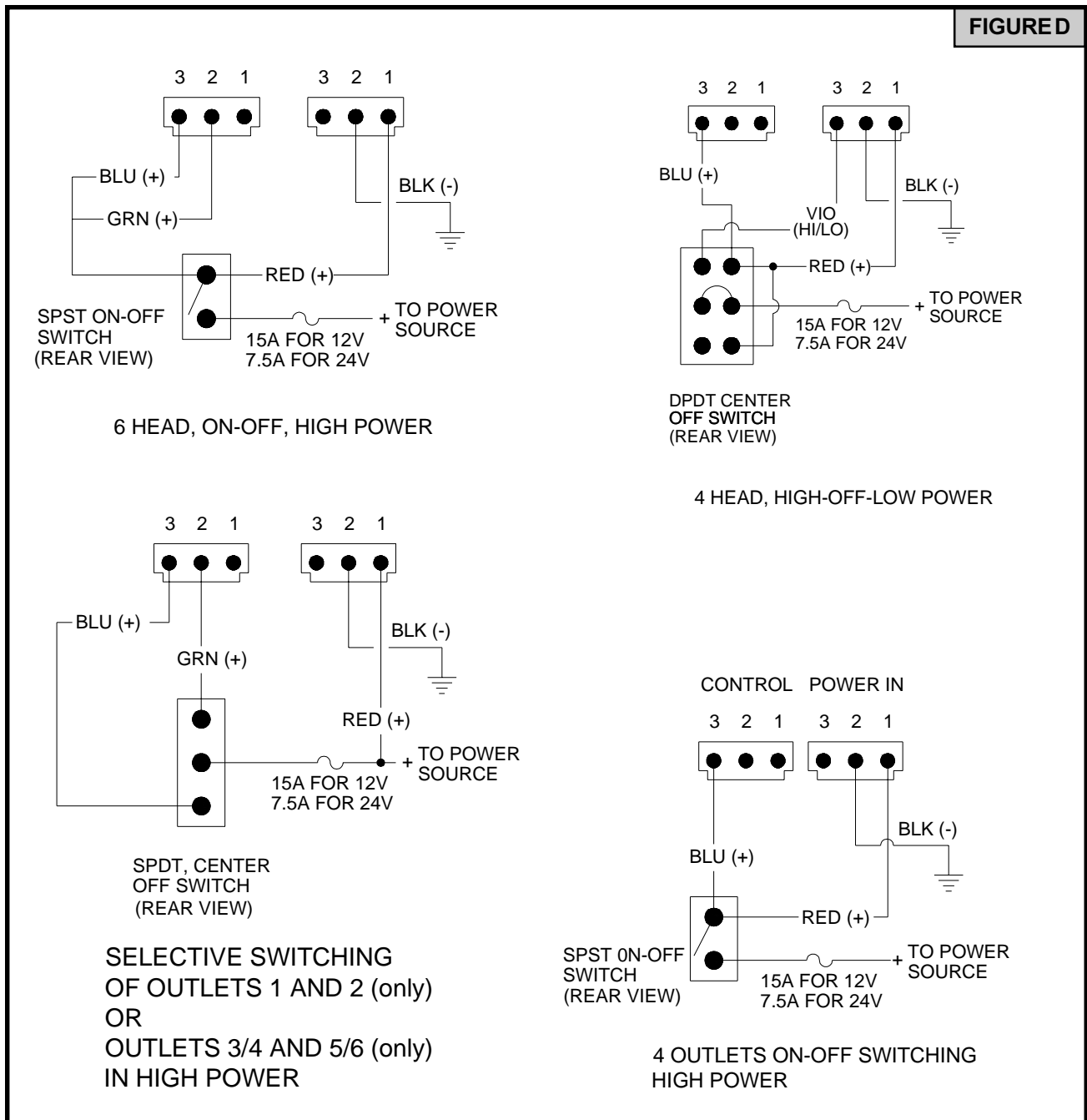
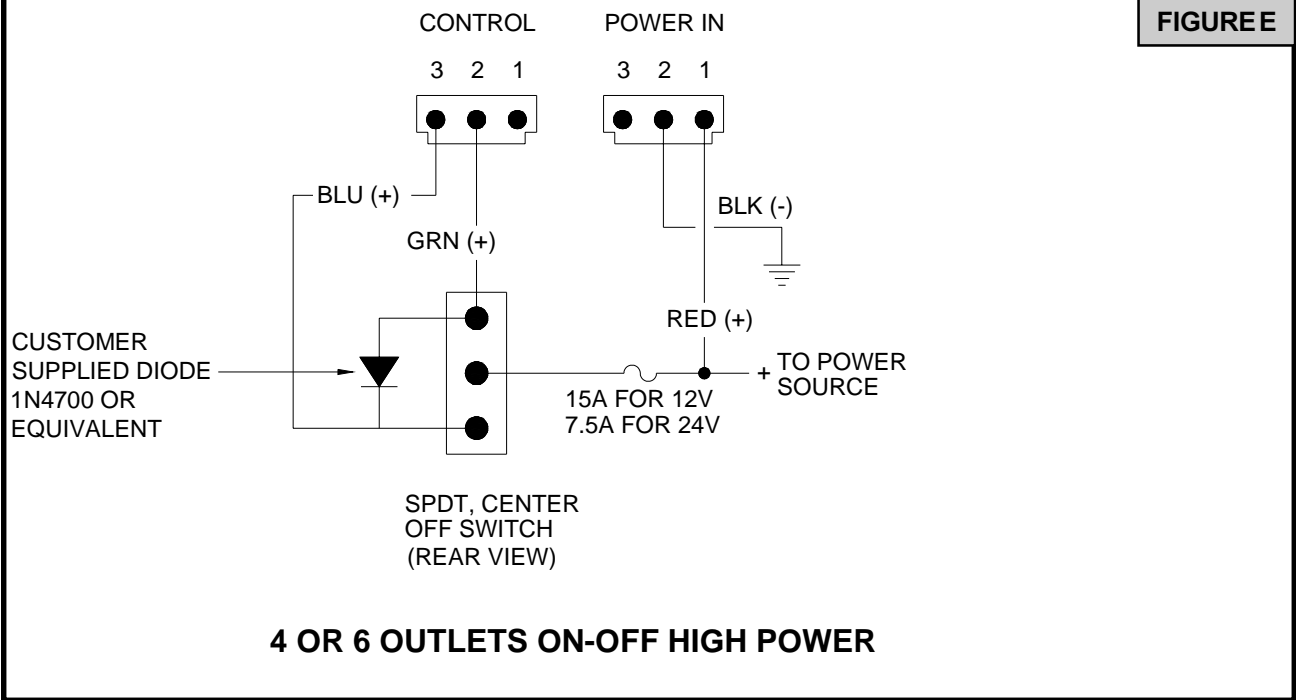

FIGURE E



FLASH PATTERN SELECTION

L1	L2	L3	L4	L5	FLASH MODE
*	-	-	-	-	Quad Flash
-	*	-	-	-	Double Flash
-	-	*	-	-	Cycle Flash 1
-	-	-	*	-	Quad Flash Slow/Fast
-	-	-	-	*	Five Flash All Heads
*	*	-	-	-	Quad Flash Slow
*	-	*	-	-	Double-Triple Flash
*	-	-	*	-	Double-Double Flash
*	-	-	-	*	Fast Single Flash
-	*	*	-	-	Triple Flash
-	*	-	*	-	Variable flash
-	*	-	-	*	Cycle Flash 2

* Indicated LED is lighted

FOR NFPA COMPLIANT INSTALLATION, SELECT QUAD OR FIVE FLASH MODES

WARNING: To achieve the maximum performance from your strobe tubes, do not mix Helix tubes and Linear Tubes. Run all Helix or all Linear strobe tubes on the odd numbered outputs of the power supply (1,3,5), and run all of the alternate style tubes on the even numbered outputs. (2,4,6). Mixing strobe tubes on the even or odd numbered outputs will cause one type to flash brighter than the other type and will reduce the life expectancy of the brighter flashing tube.

MAINTENANCE

The CPS690 Remote Strobe Power Supply has been designed to provide trouble free service. In case of difficulty, refer to the Troubleshooting section. Periodic inspection of power supply wiring, and strobe light head connections for shorted or open wires will assure trouble free operation. The primary cause of short circuits has been found to be wires passing through firewalls, roofs, etc.

Troubleshooting

NOTE: DO NOT TAMPER WITH THE POWER SUPPLY. THIS UNIT IS SOLD AS A COMPLETE MODULE, AND IS NOT DESIGNED FOR FIELD REPAIR. REMOVING THE TOP CASE CAN RESULT IN ELECTRIC SHOCK AND WILL VOID THE WARRANTY.

All CPS690 Remote Strobe Power Supply units are thoroughly tested before shipment. However, should you encounter a problem during installation or during the life of the product, refer to the guide below for information on troubleshooting. In most cases problems that occur will be related either to the power/control wiring, or to the strobe light head cables that connect them to the strobe power supply. In the event that the strobe power supply is at fault return the unit to the factory for service.

TROUBLESHOOTING GUIDE

PROBLEM	CAUSE	SOLUTION
External fuse blows	<ol style="list-style-type: none"> 1. Power input wires reversed 2. Power supply failure 3. Incorrect fuse size 	<ol style="list-style-type: none"> 1. Check power connections 2. Return for service 3. Replace with a 15A
Light heads do not fire	<ol style="list-style-type: none"> 1. Cable connections loose at power supply or light head 2. Cable to light heads damaged and shorting to chassis 3. Cable terminated improperly in 3 pin AMP connector 4. Bad strobe tube 	<ol style="list-style-type: none"> 1. Check all connections 2. Isolate damaged cable by disconnecting and reconnecting outputs one at a time. Repair or replace the damaged cable. (When other heads come back on the one that is disconnected is the shorted line.) 3. Check wire orientations at 3 pin connectors 4. Replace strobe tube assembly
Incorrect flash pattern	<ol style="list-style-type: none"> 1. Control harness wiring and or switches not connected properly 2. Light heads plugged into wrong outlet on the power supply 	<ol style="list-style-type: none"> 1. Check wiring/switches. Refer to Table 1 to verify selections. 2. Follow designations on label for outlets and move to proper outlet.
Flash patterns change continuously	<ol style="list-style-type: none"> 1. Power Supply is in CYCLE FLASH mode. Proper operation. 	<ol style="list-style-type: none"> 1. Brown wire is connected to +VDC. Check control harness/switches. If CYCLE MODE is not desired change connections.

NOTES

NOTES

WARRANTY

This product was tested and found to be operational at the time of manufacture. Provided this product is installed and operated in accordance with the manufacturer's recommendations, Public Safety Equipment guarantees the CPS690 for a period of 5 years from the date of purchase or delivery, whichever is later. Units demonstrated to be defective within the warranty period will be repaired or replaced at the factory service center at no cost.

Use of a lamp or other electrical load of a wattage higher than installed or recommended by the factory, or use of inappropriate or inadequate wiring or circuit protection causes this warranty to become void. Failure or destruction of the product resulting from abuse or unusual use and/or accidents is not covered by this warranty. Use of non-PSE components and assemblies may cause damage to the system and/or personal injury, and voids all warranties on PSE systems and components.

PSE shall in no way be liable for other damages including consequential, indirect or special damages whether loss is due to negligence or breach of warranty.

PSE MAKES NO OTHER EXPRESS OR IMPLIED WARRANTY INCLUDING, WITHOUT LIMITATION, WARRANTIES OF FITNESS OR MERCHANTABILITY, WITH RESPECT TO THIS PRODUCT.

PRODUCT RETURNS

In order to provide you with faster service, if you are going to return a product for repair or replacement*, please contact our factory to obtain a Return Goods Authorization Number (RGA number) before you ship the product to PSE. Write the RGA number clearly on the package near the mailing label. Be sure you use sufficient packing materials to avoid damage to the product being returned while in transit.

*PSE reserves the right to repair or replace product at its discretion. PSE assumes no responsibility or liability for expenses incurred for the removal and/or reinstallation of products requiring service and/or repair.

NEED HELP? Call our Technical Assistance Hotline - (314) 996-2800

CODE 3[®]
PUBLIC SAFETY EQUIPMENT, INC.

Public Safety Equipment (UK), Ltd.
Oldham Road, Rishworth
Halifax, West Yorkshire—ENGLAND HX6 4QG
Ph. 0422-824640 Fax 0422-824604

Public Safety Equipment, Inc.
10986 N. Warson Road
St. Louis, Missouri 63114-2029—USA
Ph. (314) 426-2700 Fax (314) 426-1337

Code 3 is a registered trademark of Public Safety Equipment, Inc.
CycleFlash is a trademark of Public Safety Equipment, Inc.

Revision 1, 01/07 - Instruction Book Part No. T11444
©2007 Public Safety Equipment, Inc. Printed in USA