

INSTALLATION & OPERATION MANUAL

NIGHTPROBE[™]

REMOTE CONTROLLED SPOTLIGHT

PATENT PENDING



Code 3, Inc., a subsidiary of
Public Safety Equipment, Inc.

CODE 3[®]
PUBLIC SAFETY EQUIPMENT, INC.

NP 130

NIGHTPROBE[™]

REMOTE CONTROLLED SPOTLIGHT

Contents:

Introduction (with warnings)	2
Unpacking & Pre-Installation	2
Installation & Mounting	2
Controller Installation.....	3
Wiring Instructions	3
Maintenance	4
Parts List (Replacement Parts/Exploded View) 5,6	
Troubleshooting.....	7
Specifications	7
Warranty	8

IMPORTANT:

*Read all instructions and warnings before installing and using.
INSTALLER: This manual must be delivered to the end user of this
equipment.*



WARNING!

The use of this or any warning device does not insure that all drivers can or will observe or react to an emergency warning signal. Never take the right-of-way for granted. It is your responsibility to be sure you can proceed safely before entering an intersection, driving against traffic, responding at a high rate of speed, or walking on or around traffic lanes. The effectiveness of this warning device is highly dependent upon correct mounting and wiring. Read and follow the manufacturer's instructions before installing or using this device. The vehicle operator should insure daily that all features of the device operate correctly. In use, the vehicle operator should insure the projection of the warning signal is not blocked by vehicle components (i.e.: open trunks or compartment doors), people, vehicles, or other obstructions.

This equipment is intended for use by authorized personnel only. It is the user's responsibility to understand and obey all laws regarding emergency warning devices. The user should check all applicable city, state and federal laws and regulations.

Code 3, assumes no liability for any loss resulting from the use of this warning device.

Note:

This device complies with Part 15 of the FCC Rules. Operation is subject to the following two conditions: (1) This device may not cause harmful interference, and (2) this device must accept any interference received, including interference that may cause undesired operation.

The user is cautioned that changes or modifications not expressly approved by CODE 3 for compliance could void the user's authority to operate this equipment.

Introduction

The NightProbe[®], NP 130, product is a remote control spotlight that delivers more signal power and versatility than any other spotlight product.

Its low profile aerodynamic lines reduce air drag, which results in fuel savings and stability at high speeds. This product is made of shock-resistant high-temperature engineering thermoplastics and provides a warning signal that exceeds SAE standards.

The NightProbe[®] and its mounting system is designed to operate in many different locations including on the driver side, passenger side or center of the automobile hood rear lip.

Unpacking & Pre-installation

Remove the spotlight from the box and examine the unit for transit damage. Refer to parts list to insure that all parts are present for installation.

Installation & Mounting

1. Attach suction cup to bottom of mounting bracket with the #10 self tapping screw, do not over tighten.
2. Route the cables from the bottom of the spotlight through the mounting bracket as shown in Figure 1.
3. Attach bracket to spotlight with four round hd phillips 6-20 x 3/8" SS as shown in Figure 1.
4. Choose a location where the spotlight is to be mounted.
5. Lay out the cable to insure that there is an adequate amount to reach the area in which the controller is to be mounted.
6. Fold wires into pocket of bracket in between the two mounting screws
7. Push bracket over lip of the hood and push down on suction cup
8. Tighten screws under hood until bracket is snug.

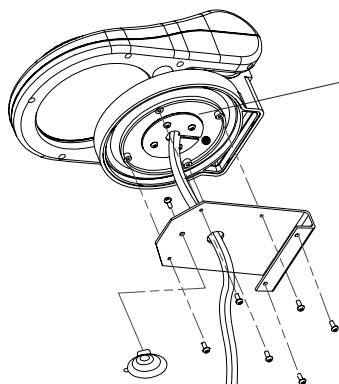
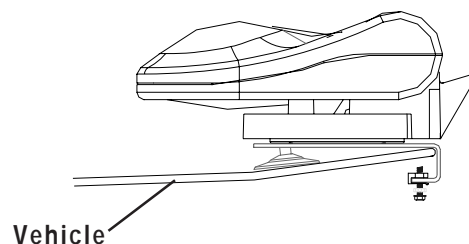

Figure 1

For proper bracket alignment make sure that the mark is to rear of NightProbe[®] as shown.





WARNING!

Route wiring using grommets and sealant when passing through compartment walls. High ambient temperatures (e.g. under-hood) will significantly reduce the current carrying capacity of wires, fuses, and circuit breakers. Use "SXL" type wire in engine compartment. Minimize the number of splices to reduce voltage drop. All wiring should conform to the minimum wire size and other recommendations of the manufacturer and be protected from moving parts and hot surfaces. Loops, grommets, cable ties, and similar installation hardware should be used to anchor and protect all wiring. Particular attention should be paid to the location and method of making electrical connections and splices to protect these points from corrosion and loss of conductivity. Ground terminations should only be made to substantial chassis components, preferably directly to the vehicle battery. The user should install a fuse sized to approximately 125% of the maximum amp capacity in the supply line and each switched circuit to protect against short circuits.



WARNING!

Any electronic device may create or be affected by electromagnetic interference. After installation of any electronic device, operate all equipment simultaneously to insure that operation is free of interference.

Wiring Instructions

Connect the red and black wires from the NightProbe® spotlight as shown in Figure 2. Protect the circuit with a 15 Amp fuse and use 14 awg (minimum) wire.

Connect the white wire from the unit to an ignition switched circuit protected by a fuse (3 Amp Max.). Use a 22 awg. (minimum) wire.

IMPORTANT:

Failure to connect the wiring as stated above could cause damage to the unit. The NightProbe® spotlight must never have its lamp on when its head is in the closed position (as shown in Figure 2). The extreme heat of the 100W lamp will damage the unit base.

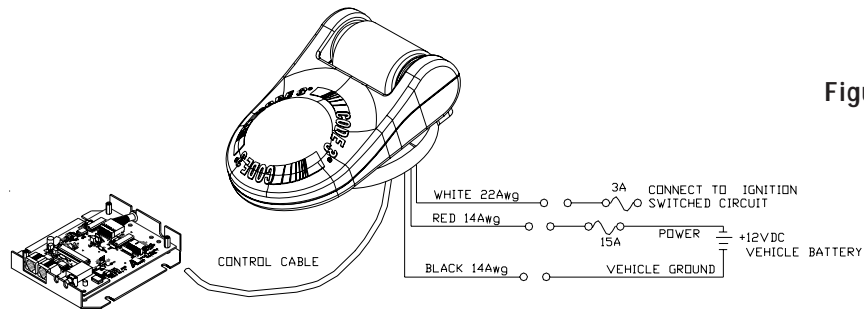

Figure 2

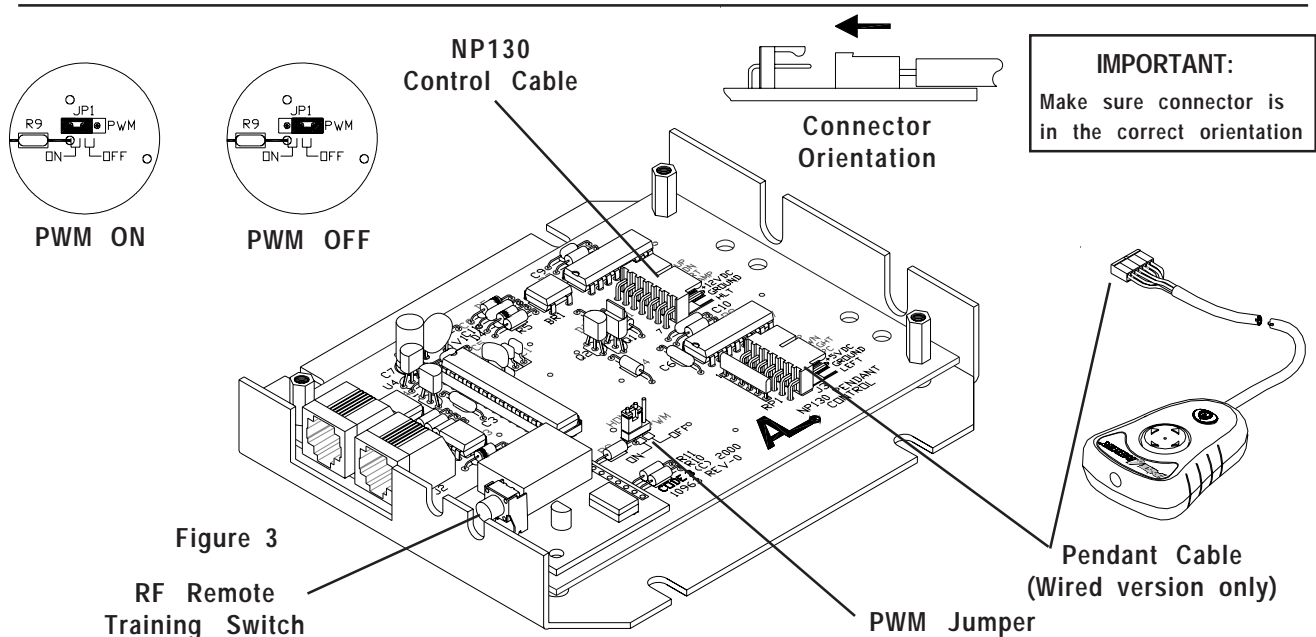

Figure 3

Operation

The NightProbe™ is designed for Electro-mechanical use.

The Night Probe controller provides a four-position switch for lighthouse movement and a push-on/push-off switch for lamp control. The four-position switch provides either single-speed movement or Pulse Width Modulated (PWM) acceleration from slowest to fastest speed. This feature is controlled by the position of the PWM configuration jumper (JP1) which is located inside the Interface Module (see Figure 3). When the PWM configuration jumper is set to the OFF position depressing and holding the four-position switch in the LEFT, RIGHT, UP or DOWN direction will cause the Night Probe® lighthouse to rotate in the appropriate direction in single speed mode. When the jumper is set to the ON position the Night Probe® lighthouse will accelerate from its slowest speed to full speed over a two second period and stop instantly when the switch is released. This mode allows for very precise positioning of the light.

The NightProbe™ 130 RF is designed for use with an optional RF Remote Control.

The NP 130 RF Remote Control comes complete with battery installed. The NP 130 control must be trained to recognize your remote unit. After installation, apply power to your NP130 system.

Depress and hold the training switch on the receiver located through a hole in the case near the antenna (see Fig 3). While holding the training switch, depress and release the small switch (Lamp ON/OFF) on the remote unit. Release the training switch and test the unit.

The RF Remote Control operation is the same as that described for the wired control.

Please note that radio transmitters and other electronic equipment can emit signals which may interfere with the operation of the RF Remote Control and cause temporary intermittent operation of the spotlight. This is considered normal. **Warning!**

CONTROLLER pendant and control module are NOT WATERPROOF

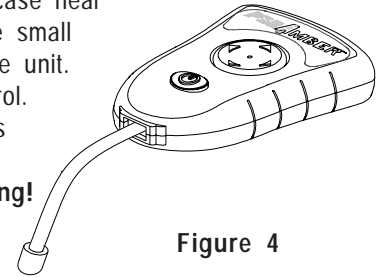

Figure 4

Maintenance



LAMPS ARE EXTREMELY HOT! ALLOW TO COOL COMPLETELY BEFORE ATTEMPTING TO REMOVE. GLOVES AND EYE PROTECTION SHOULD BE WORN WHEN HANDLING HALOGEN LAMPS AS THEY ARE PRESSURIZED AND ACCIDENTAL BREAKAGE CAN RESULT IN FLYING GLASS.

WARNING!

Lamp Replacement

1. Insure that ignition is in off position.
2. Lift spotlight head so that it is facing up as in Figure 5.
3. Remove 7 screws in lower bulb shell and lift it off upper bulb shell.
4. Disconnect power and ground wire from lamp.
5. Replace lamp (H-3 100W) as shown in Figure 6.
6. Connect power and ground to lamp.

(IMPORTANT: FEED POWER AND GROUND WIRE BACK THROUGH HEAT SHIELD WITH FABRIC SIDE FACING BULB AS SHOWN). Both wires must be positioned behind the protective heatshield.

7. Be sure to align the upper and lower shells with the proper key on the vertical gear (see Figure 7) Reattach the 7 screws. Do not overtighten.

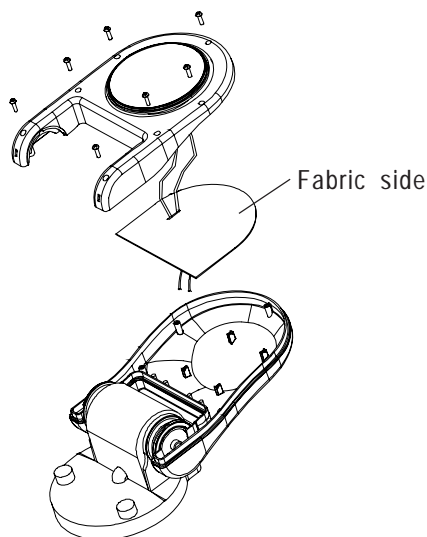

Figure 5

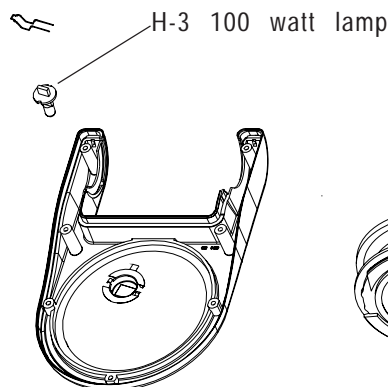

Figure 6

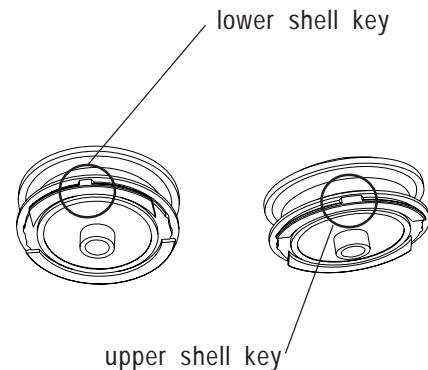
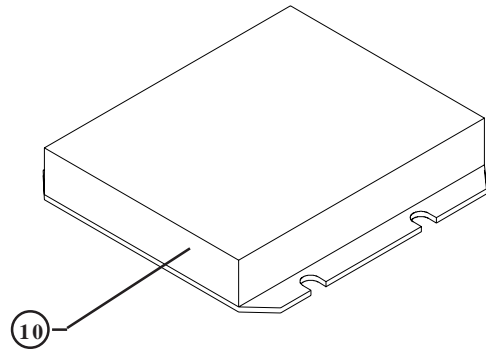
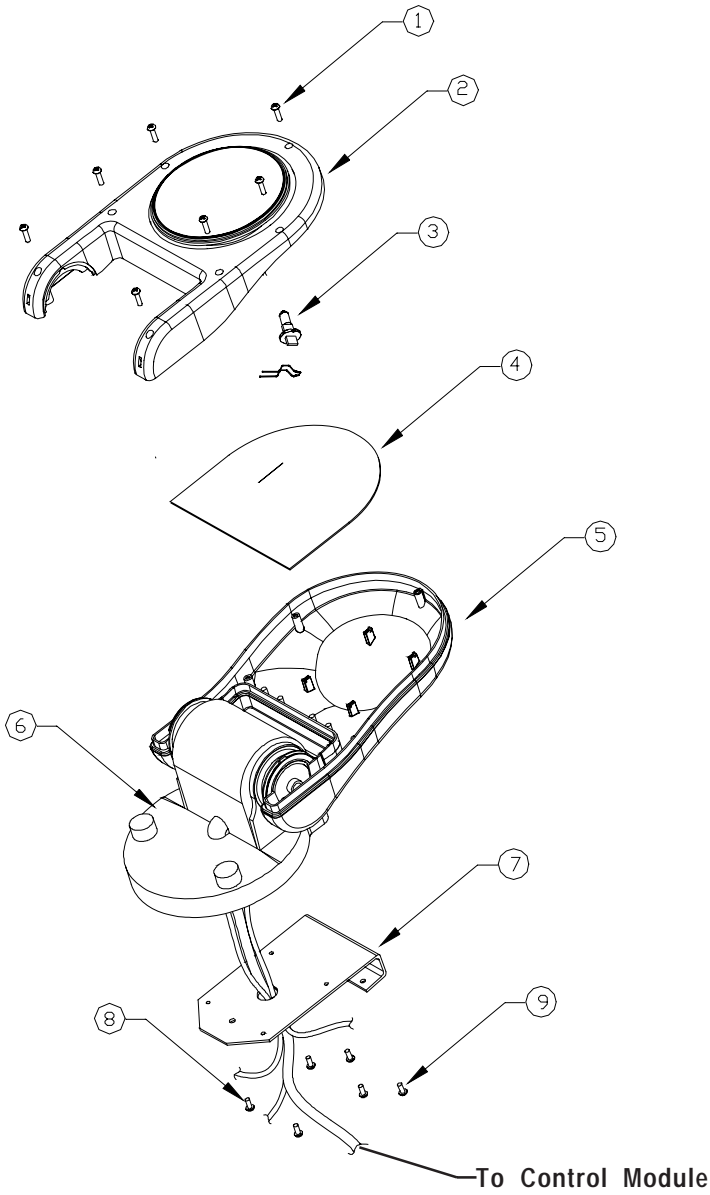
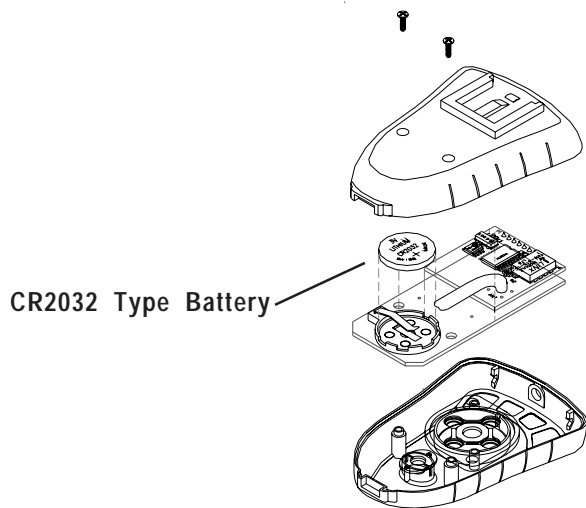
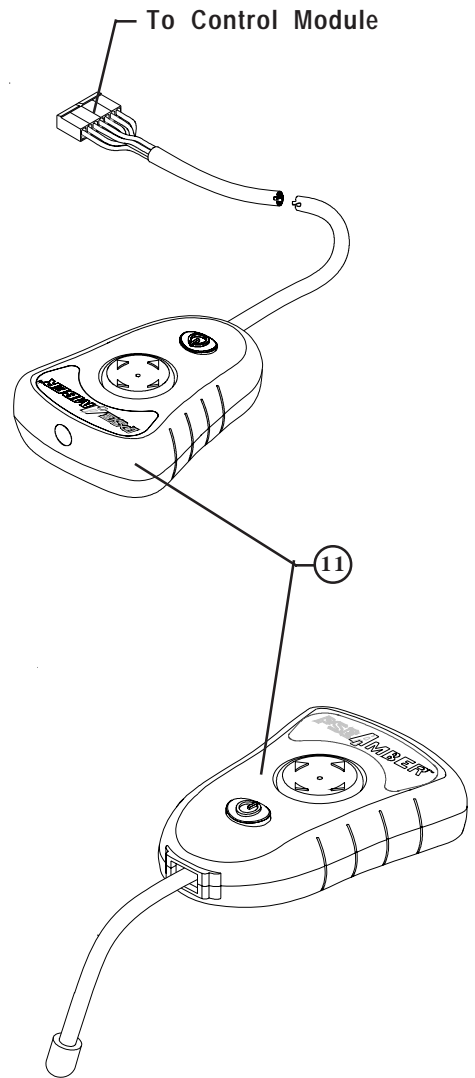

Figure 7

Parts & Exploded Views



Control Module



Parts List

<u>Ref No.</u>	<u>Description</u>	<u>Part No.</u>	<u>Qty.</u>
1	SMS,Pan Hd Phil. #8 x 1/2"lg 'PT' screw	T06828	07
2	Lower Bulb Shell	T06878	01
3	H-3 100W Lamp	T05379	01
4	Heat Shield	T06881	01
5	Upper Bulb Shell	T06877	01
6	Motor Housing	S81832	01
7	Mounting Bracket	S81835	01
8	SMS,Round Hd phil, 6-20 x 3/8", ss	T01591	04
9	Ms, slot, Hx, Hd ,10-24 x 3/4"lg	T06897	02
10	NP 130 Wired Control Module	S71607	01
	Wireless Control Module for S71607	S71613	01
11	NP 130 Wired Control Pendant	S71615	01
	NP 130 Wireless Control Pendent	S71612	01
	NOT SHOWN		
	Belt Clip	T10974	01
	Boot, vinyl-yellow	T10975	01
	Battery, CR2032	T10988	01

Troubleshooting

PROBLEM	PROBABLE CAUSE	REMEDY
Product does not activate	a. No power to unit b. Fuse blown c. Ignition not on d. Controller cable not connected f. Damaged or shorted cabling	a. Check wiring b. Replace fuse c. Turn on ignition d. Check cable connection f. Check cables for damage
Unit operates but no light	a. Lamp burned out b. Switch on controller not engaged	a. Replace lamp b. Push button on controller
Light operates but unit not moving	a. Motor damage b. Unit hitting obstacle	a. Return to Code 3 Inc. b. Remove obstacle

Specifications:

Mechanical	Dimensions:	Width: 7.25" Depth: 12" Height: lamp down 4" lamp raised 12"
	Rotation:	360 degrees
	Electrical:	
Operating	Voltage:	10 - 15 VDC
Current	draw:	
	Lamp 'on'	approx. 10A @ 12.8 VDC
	Lamp 'off'	approx. 35mA @ 12.8 VDC
	Lamp Rating	100 Watts @ 12.8 VDC

Finishing:

To prepare the surface of the Night Probe for finishing wipe it with alcohol or clean ultrasonically.

Mask off all bearing surfaces before finishing.

Water base and solvent paints based on aliphatic hydrocarbons (mineral spirits, heptane, hexane and alcohols) have good compatibility with the Night Probe material.

Chlorinated and aromatic solvents, as well as ketones should generally be avoided.

Curing:

Paints used on the Night Probe material can be cured using either air-dry or bake techniques. Circulating warm air ovens are the best suited and most economical method of drying.

Curing conditions will vary depending on the coating and part design. Bake temperatures of 250 degrees F (121degrees C) are acceptable with Night Probe material.

WARRANTY

Code 3, Inc.'s emergency devices are tested and found to be operational at the time of manufacture. Provided they are installed and operated in accordance with manufacturer's recommendations, Code 3, Inc. guarantees all parts and components except the lamps to a period of 1 year (unless otherwise expressed) from the date of purchase or delivery, whichever is later. Units demonstrated to be defective within the warranty period will be repaired or replaced at the factory service center at no cost.

Use of lamp or other electrical load of a wattage higher than installed or recommended by the factory, or use of inappropriate or inadequate wiring or circuit protection causes this warranty to become void. Failure or destruction of the product resulting from abuse or unusual use and/or accidents is not covered by this warranty. Code 3, Inc. shall in no way be liable for other damages including consequential, indirect or special damages whether loss is due to negligence or breach of warranty.

CODE 3, INC. MAKES NO OTHER EXPRESS OR IMPLIED WARRANTY INCLUDING, WITHOUT LIMITATION, WARRANTIES OF FITNESS OR MERCHANTABILITY, WITH RESPECT TO THIS PRODUCT.

PRODUCT RETURNS

If a product must be returned for repair or replacement*, please contact our factory to obtain a Return Goods Authorization Number (RGA number) before you ship the product to Code 3, Inc. Write the RGA number clearly on the package near the mailing label. Be sure you use sufficient packing materials to avoid damage to the product being returned while in transit.

*Code 3, Inc. reserves the right to repair or replace at its discretion. Code 3, Inc. assumes no responsibility or liability for expenses incurred for the removal and /or reinstallation of products requiring service and/or repair; nor for the packaging, handling, and shipping; nor for the handling of products return to sender after the service has been rendered.

PROBLEMS OR QUESTIONS? CALL OUR TECHNICAL ASSISTANCE HOTLINE (314) 996-2800

WWW.CODE3PSE.COM

Code 3, Inc., a subsidiary of
Public Safety Equipment, Inc.

CODE 3[®]
PUBLIC SAFETY EQUIPMENT, INC.

Code 3[®], Inc.
10986 N. Warson Road
St. Louis, Missouri 63114-2029—USA
Ph. (314) 426-2700 Fax (314) 426-1337

Part No. T06888 Rev. 7 5/2006

©2005 Code 3, Inc

Code 3[®] is a registered trademark of Code 3, Inc., a subsidiary of Public Safety Equipment, Inc.