

INSTALLATION & OPERATION MANUAL

MODEL
PB100

Patent Pending

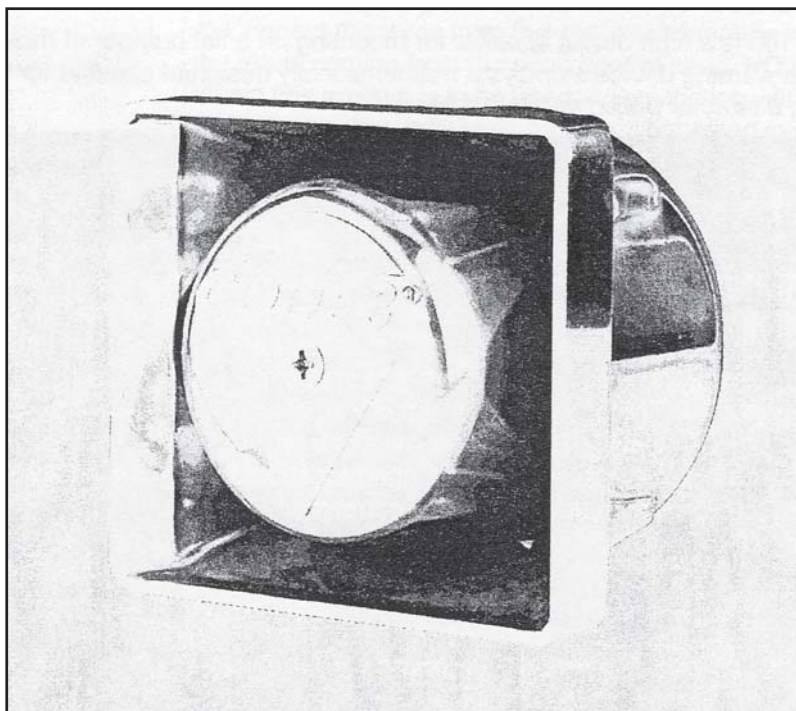

Code 3, Inc., a subsidiary of
Public Safety Equipment, Inc.

CODE 3[®]
PUBLIC SAFETY EQUIPMENT, INC.

PB100

CONTENTS:

Introduction	2
Installation & Mounting	2-3
Maintenance	4
Parts List	5
Troubleshooting	5
Warranty	8

IMPORTANT:

Read all instructions and warnings before installing and using.

INSTALLER:

This manual must be delivered to the end user of this equipment.

Introduction

The PB100 is a high output speaker for mounting on a flat bumper of most emergency vehicles. This highly effective warning device employs a mathematically designed speaker for maximum sound volume whether used as a siren or public address system.



Sirens are an integral part of an effective audio/visual emergency warning system. However, sirens are only short range secondary warning devices. The use of a siren does not insure that all drivers can or will observe or react to an emergency warning signal, particularly at long distances or when either vehicle is traveling at a high rate of speed. Sirens should only be used in a combination with effective warning lights and never relied upon as a sole warning signal. Never take the right of way for granted. It is your responsibility to be sure you can proceed safely before entering an intersection, driving against traffic, or responding at a high rate of speed. The effectiveness of this warning device is highly dependent upon correct mounting and wiring. Read and follow the manufacturer's instruction before installing or using this device. The vehicle operator should check the equipment daily to insure that all features of the device operate correctly.

To be effective, sirens must produce high sound levels that potentially can inflict hearing damage. Installers should be warned to wear hearing protection, clear bystanders from the area and not to operate the siren indoors during testing. Vehicle operators and occupants should assess their exposure to siren noise and determine what steps, such as consultation with professionals or use of hearing protection should be implemented to protect their hearing.

This equipment is intended for use by authorized personnel only. It is the user's responsibility to understand and obey all laws regarding emergency warning devices. The user should check all applicable city, state and federal laws and regulations.

Public Safety Equipment, Inc., assumes no liability for any loss resulting from the use of this warning device.

Proper installation is vital to the performance of the siren and the safe operation of the emergency vehicle. It is important to recognize that the operator of the emergency vehicle is under psychological and physiological stress caused by the situation. The siren system should be installed in such a manner as to: A) Not reduce the acoustical performance of the system. B) Limit as much as practical the noise level in the passenger compartment of the vehicle. C) Place the controls within convenient reach of the operator so that he can operate the system without losing eye contact with the roadway,

Emergency warning devices often require high electrical voltage and/or currents. Properly protect and use caution around live electrical connections. Grounding or shorting of electrical connections can cause high current arcing, which can cause personal injury and/or severe vehical damage, including fire.

PROPER INSTALLATION COMBINED WITH OPERATOR TRAINING IN THE PROPER USE OF EMERGENCY WARNING DEVICES IS ESSENTIAL TO INSURE THE SAFETY OF EMERGENCY PERSONNEL AND THE PUBLIC.

Installation & Mounting

PLEASE NOTE - All of the information listed in this booklet must be given to the end user by the installer.

- 1) Mark positions for mounting the speaker using the bracket as a template. **PLEASE NOTE: Similar to what is shown in Figures 1 and 2, these positions must be over structural supports below the bumper surface.**
- 2) Drill holes at these inscribed positions in accordance to the following drill sizes. (Figure 1)
 - a) 5/16" bit for the speaker wiring and the cap screw attached to the speaker bell.
 - b) 9/16" bit for the two carriage bolts that fasten the speaker bracket.
- 3) Attach the speaker assembly to the bumper using the fasteners shown in Figure 2. **It is critical that the cap screw in the speaker bell be fastened securely to the bracket and preferably to a structural member in the bumper. Failure to do this will result in bracket failure and void the warranty.**

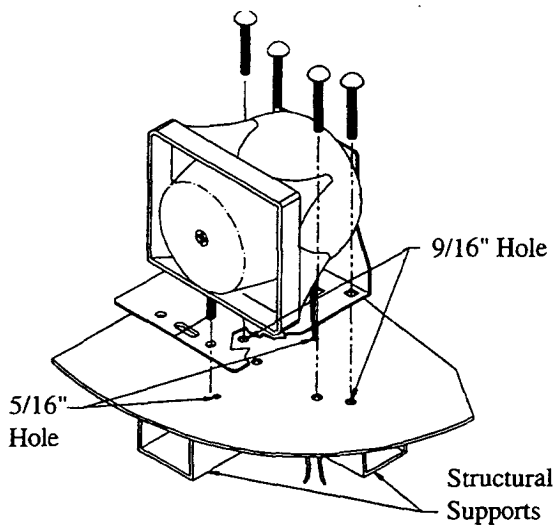

FIGURE 1

4) Connect the wires from the speaker assembly to the leads coming from the siren control head. NOTE: When this product is to be used in conjunction with another speaker, both units must be connected in phase.

To accomplish this, the white wire that is connected to the number 1 terminal on the siren driver, must be connected to the same output terminal on the amplifier as the wire originating from the number 1 terminal on the second speaker. Likewise, the blue wire that is connected to the number 2 terminal on the driver, must be connected together with the wire originating from the number 2 terminal on the second speaker.



WARNING!

All devices should be mounted in accordance with the manufacturer's instructions and securely fastened to vehicle elements of sufficient strength to withstand the forces applied to the device.

Ease of operation and convenience to the operator should be the prime consideration when mounting the siren and controls. Adjust the mounting angle to allow maximum operator visibility.

Do not mount the Contro! Head Module in a location that will obstruct the drivers view. Mount the microphone clip in a convenient location to allow the operator easy access. Devices should be mounted only in locations that conform to their SAE identification code as described in SAE Standard J1849. For example, electronics designed for interior mounting should not be placed underhood, etc.

Controls should be placed within convenient reach* of the driver or if intended for two person operation the driver and/or passenger. In some vehicles, multiple control switches and/or using methods such as "horn ring transfer" which utilizes the vehicle horn switch to toggle between siren tones may be necessary for convenient operation from two positions.

* Convenient reach is defined as the ability of the operator of the siren systems to manipulate the controls from his normal driving/riding position without excessive movement away from the seat back or loss of eye contact with the road.



WARNING!

Larger wires and tight connections will provide longer service life for components. For high current wires it is highly recommended that terminal blocks or soldered connections be used with shrink tubing to protect the connections. Do not use insulation displacement connectors (e.g. 3M® Scotchlock type connectors). Route wiring using grommets and sealant when passing through compartment walls. Minimize the number of splices to reduce voltage drop. High ambient temperatures (e.g. underhood) will significantly reduce the current carrying capacity of wires, fuses, and circuit breakers. Use "SXL" type wire in engine compartment. All wiring should conform to the minimum wire size and other recommendations of the manufacturer and be protected from moving parts and hot surfaces. Looms, grommets, cable ties, and similar installation hardware should be used to anchor and protect all wiring.

Fuses or circuit breakers should be located as close to the power takeoff points as possible and properly sized to protect the wiring and devices.

Particular attention should be paid to the location and method of making electrical connections and splices to protect these points from corrosion and loss of conductivity. Ground terminations should only be made to substantial chassis components, preferably directly to the vehicle battery.

The user should install a fuse sized to approximately 125% of the maximum Amp capacity in the supply line to protect against short circuits. For example, a 30 Amp fuse should carry a maximum of 24 Amps. **DO NOT USE 1/4" DIAMETER GLASS FUSES AS THEY ARE NOT SUITABLE FOR CONTINUOUS DUTY IN SIZES ABOVE 15 AMPS.** Circuit breakers are very sensitive to high temperatures and will "false trip" when mounted in hot environments or operated close to their capacity.



WARNING!

CONNECTION OF A 58 WATT SPEAKER TO THE 100 WATT TERMINAL WILL CAUSE THE SPEAKER TO BURN OUT. AND WILL VOID THE SPEAKER WARRANTY! The sound projecting opening should be pointed forward, parallel to the ground, and not obstructed or muffled by structural components of the vehicle. Concealed or under-hood mountings in some cases will result in a dramatic reduction in performance. To minimize this reduction, mount the speaker so the sound emitted is projected directly forward and obstruction by vehicle components such as hoses, brackets, grille, etc. is minimized. Electromechanical sirens and electronic siren speakers should be mounted as far from the occupants as possible using acoustically insulated compartments and isolation mountings to minimize the transmission of sound into the vehicle. It may be helpful to mount the device on the front bumper, engine cowling or fender; heavily insulate the passenger compartment and operate the siren only with the windows closed.

Each of these approaches may cause significant operational problems, including loss of siren performance from road slush, increased likelihood of damage to the siren in minor collisions, and the inability to hear the sirens on other emergency vehicles. APPROPRIATE TRAINING OF VEHICLE OPERATORS IS RECOMMENDED TO ALERT THEM TO THESE PROBLEMS AND MINIMIZE THE EFFECT OF THESE PROBLEMS DURING OPERATIONS.

MAINTENANCE

If necessary, maintenance of your PB100 involves the cleaning of the unit and the replacement of the siren driver. Allow the unit to cool for five minutes before attempting any maintenance. For replacing a burned out or defective driver, the speaker bracket assembly must be removed from the vehicle in reverse order as explained in the installation procedure. Follow the steps below once this has been accomplished. (See figure 3).

- 1) Remove the driver cap on the front face of the speaker assembly and place it on a flat surface.
- 2) Remove the four screws on the back of the assembly and disassemble the bracket, speaker bell and driver cover.
- 3) Detach the wires from the defective driver and reconnect them to the appropriate terminals on the replacement driver.
- 4) Reassemble the speaker assembly to its original state and reattach it to the vehicle following the same steps outlined in the installation and mounting section in this booklet. Make sure the wires are tightly sealed at all exit points from the speaker assembly. Fill any voids with silicone caulking.

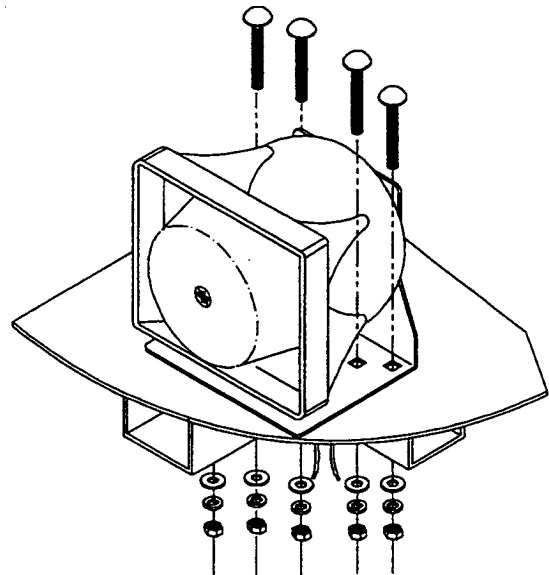

FIGURE 2

NOTE: When reassembling the speaker, make sure to align the drain holes on the driver, driver cone and driver cap (the drain hole on the Atlas driver is located on its underside behind a metal tag). These holes should be oriented to the base of speaker/bracket assembly for proper drainage and orientation of the logo on the driver cap.

CLEANING

Clean the PB100 with soap and water to remove all salt, dirt, or mud. Do not use any abrasive cleaners or harsh chemicals, because the protective coating on the aluminum may be damaged allowing the exposed aluminum to dull in appearance or corrode.

Parts List

<u>Ref No.</u>	<u>Description</u>	<u>Part No.</u>	<u>Qty.</u>
1	Speaker Wire Assemblies	51020 & 51021	1
2	Speaker Screws	T06519	2
3	Plated Mounting Bracket	S70059	1
4	Speaker Horn	T06514	1
5	Driver Cover	T03739	1
6	Speaker Driver	T03470	1
7	Driver Cap	T06508	1
8	Nose Cone Screw	T06530	1

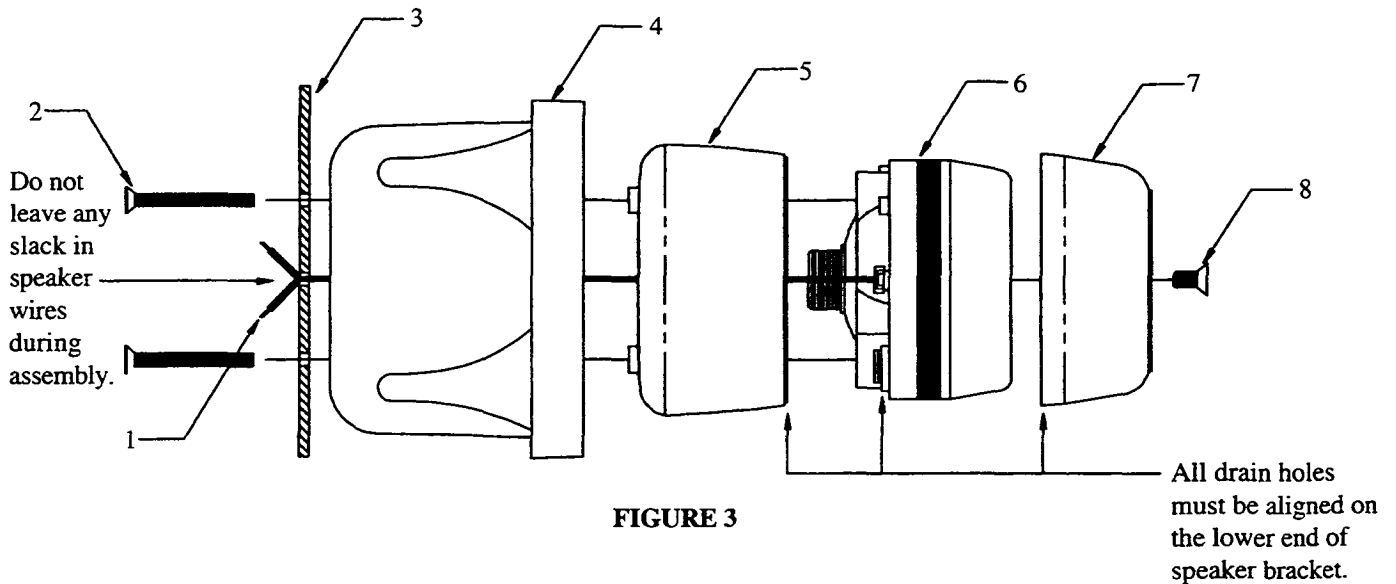

TROUBLESHOOTING		
PROBLEM	PROBABLE CAUSE	REMEDY
No output from speaker, siren amplifier makes noise	A. Open circuit in speaker wiring B. Defective driver(s)	A. Check connections at amplifier and siren amplifier B. Check resistance across speaker wires (3.8 Ohms) and replace drivers
Low output from speaker	A. Low voltage from amplifier B. Dual speakers not connected in phase	A. Refer to siren amplifier owners manual B. Refer to speaker wiring instructions in manual.

NOTES

NOTES

WARRANTY

This product was tested and found to be operational at the time of manufacture. Provided this product is installed and operated in accordance with the manufacturer's recommendations, Public Safety Equipment guarantees all strobe reflector assemblies and all other parts and components for a period of 1 year from the date of purchase or delivery, whichever is later. Units demonstrated to be defective within the warranty period will be repaired or replaced at the factory service center at no cost.

Use of a lamp or other electrical load of a wattage higher than installed or recommended by the factory, or use of inappropriate or inadequate wiring or circuit protection causes this warranty to become void. Failure or destruction of the product resulting from abuse or unusual use and/or accidents is not covered by this warranty. Use of non-Code 3 components and assemblies may cause damage to the system and/or personal injury, and voids all warranties on PSE systems and components.

Code 3, Inc. shall in no way be liable for other damages including consequential, indirect or special damages whether loss is due to negligence or breach of warranty.

CODE 3, INC. MAKES NO OTHER EXPRESS OR IMPLIED WARRANTY INCLUDING, WITHOUT LIMITATION, WARRANTIES OF FITNESS OR MERCHANTABILITY, WITH RESPECT TO THIS PRODUCT.

PRODUCT RETURNS

In order to provide you with faster service, if you are going to return a product for repair or replacement*, please contact our factory to obtain a Return Goods Authorization Number (RGA number) before you ship the product to Code 3. Write the RGA number clearly on the package near the mailing label. Be sure you use sufficient packing materials to avoid damage to the product being returned while in transit.

*Code 3, Inc. reserves the right to repair or replace product at its discretion and assumes no responsibility or liability for expenses incurred for the removal and/or reinstallation of products requiring service and/or repair.

NEED HELP? Call our Technical Assistance Hotline - (314) 996-2800

Code 3,® Inc., a subsidiary of
Public Safety Equipment, Inc.

 **CODE 3**[®]
PUBLIC SAFETY EQUIPMENT, INC.

Code 3, Inc.
10986 N. Watson Road
St. Louis, Missouri 63114-2029—USA
www.code3pse.com