

INSTALLATION & OPERATION MANUAL



PSE235™
REMOTE STROBE
POWER SUPPLY

Code 3, Inc., a subsidiary of
Public Safety Equipment, Inc.

CODE 3[®]
PUBLIC SAFETY EQUIPMENT, INC.

PSE235

REMOTE STROBE POWER SUPPLY

Contents:

Introduction	2
Standard Features	2
Specifications	2
Unpackaging & Pre-installation	3
Installation & Mounting	4
Wiring Instructions	4-6
Switching Control Variations	7
Maintenance	8
Troubleshooting	8
Internal Fuse Replacement	9
Warranty	10

IMPORTANT:

Read all instructions and warnings before installing and using.

INSTALLER: *This manual must be delivered to the end user of this equipment.*

Introduction

The PSE235 Series Remote Strobe Power Supply represents the latest in state-of-the-art strobe warning technology. The latest in MOSFET technology and microprocessor control provide efficient and reliable operation. The model PSE235 is versatile and economical strobe power supply providing two alternating strobe outlets. When connected to *CODE 3*[®] line of oval and round remote strobe heads, remote 360 beacon, and accessories the PSE235 delivers an outstanding level of vehicle warning signals.

Standard Features

All MODEL PSE235 two-head Remote Strobe Power Supplies come equipped with the following standard features: (See Figure 3, page 5)

MULTIPLE OPERATING VOLTAGES

10-30 VDC operation only. Reverse polarity protected

INTERNAL FUSE PROTECTION

User replaceable 7.5 AMP, ATO style fuse.

OUTPUT SHORT CIRCUIT/FLASH TUBE FAILURE PROTECTION

Power supply will shut-off when trying to flash any heads that have been shorted, or have a failed flash tube.

MULTIPLE USER SELECTABLE FLASH PATTERNS

User may select either Double Flash or Quad Flash.

H/LO POWER CONTROL

Allows reduction of strobe light intensity for night time use. The Lo power control is +VDC switched.

Specifications

OPERATING VOLTAGE: 10-30 VDC

OUTPUT POWER: 35 WATTS NOMINAL

STANDARD FLASH RATE: EACH STROBE LIGHT OUTLET 60 QUAD FLASHES/MIN.

POWER CONSUMPTION: 3.5 AMPS AVERAGE AT 12.8 VDC (HIGH POWER)
 1.75 AMPS AVERAGE AT 25.6 VDC (HIGH POWER)



The use of this or any warning device does not insure that all drivers can or will observe or react to an emergency warning signal. Never take the right-of-way for granted. It is your responsibility to be sure you can proceed safely before entering an intersection, driving against traffic, responding at a high rate of speed, or walking on or around traffic lanes. The effectiveness of this warning device is highly dependent upon correct mounting and wiring. Read and follow the manufacturer's instructions before installing or using this device. The vehicle operator should insure daily that all features of the device operate correctly. In use, the vehicle operator should insure the projection of the warning signal is not blocked by vehicle components (i.e.: open trunks or compartment doors), people, vehicles, or other obstructions.

This equipment is intended for use by authorized personnel only. It is the user's responsibility to understand and obey all laws regarding emergency warning devices. The user should check all applicable city, state and federal laws and regulations.

Public Safety Equipment, Inc., assumes no liability for any loss resulting from the use of this warning device.

Proper installation is vital to the performance of this warning device and the safe operation of the emergency vehicle. It is important to recognize that the operator of the emergency vehicle is under psychological and physiological stress caused by the emergency situation. The warning device should be installed in such a manner as to: A) Not reduce the output performance of the system, B) Place the controls within convenient reach of the operator so that he can operate the system without losing eye contact with the roadway.

Emergency warning devices often require high electrical voltages and/or currents. Properly protect and use caution around live electrical connections. Grounding or shorting of electrical connections can cause high current arcing, which can cause personal injury and/or severe vehicle damage, including fire. Do not touch the strobe light tubes, the strobe light head assemblies or the strobe power supply while the system is in operation. Wait 5 minutes after turning off the power from system before touching any internal componentry. **PROPER INSTALLATION COMBINED WITH OPERATOR TRAINING IN THE PROPER USE OF EMERGENCY WARNING DEVICES IS ESSENTIAL TO INSURE THE SAFETY OF EMERGENCY PERSONNEL AND THE PUBLIC.**

Unpacking and Pre-Installation

Remove the power supply from the box and examine the unit for any transit damage. Report any damage to the carrier immediately. Inspect the supplied user parts kit , this should contain:

- A. 1 POWER INPUT/CONTROL HARNESS ASSEMBLY** consisting of one AMP 4 pin connector with four wires, Red power wire positive (+12/24VDC), Black wire negative (Ground/Earth), Orange (Quad Flash Selection) and Green wire (Hi/Lo intensity). This assembly is to be connected to customer supplied power harness and control switching.
- B. TWO AMP 3-PIN PLUG HOUSINGS** to be connected to the remote strobe light head cables. (See Installation and Mounting section).
- C. FOUR #8 SHEET METAL SCREWS** for mounting the power supply.

Installation and Mounting

MOUNTING THE MODEL PSE235 REMOTE STROBE POWER SUPPLY

To obtain maximum performance and durability the Model PSE235 should be mounted as follows:

1. Mount the unit with the strobe light outlets located in such a way that they are easily accessible.
2. Mount the unit with the four supplied #8 sheet metal screws. If possible, a metal surface should be chosen for best heat dissipation. The mounting hole pattern dimensions are shown in Figure 1. The power supply can be used as a template, if desired, to mark the drill locations. Pre-drill this surface with a 9/64 drill and secure the unit.

 The Model PSE235 Strobe Power Supply is NOT waterproof and should be located in an area protected from the weather and water.

WARNING!

 High voltages and/or temperatures are present inside the unit. Disconnect from power and wait 5 minutes prior to servicing or troubleshooting. Use hand and eye protection when changing halogen lamps or flashtubes.

WARNING!

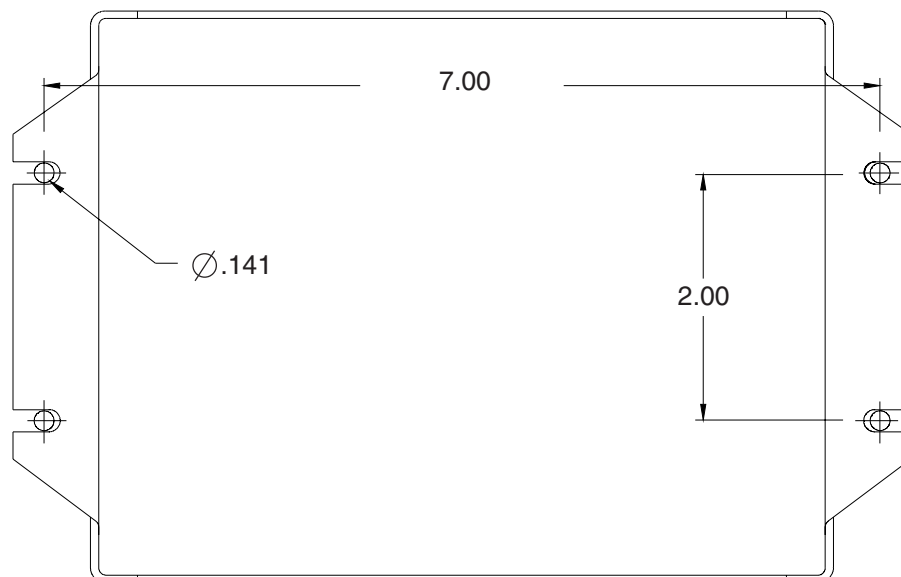

FIGURE 1

WRING

STROBE LIGHT HEAD CABLE CONNECTIONS

1. Install the remote strobe light heads in the desired locations and route the three wire cable from the remote heads to the PSE235 power supply. Leave enough cable at the power supply so that the cables are not strained when connected to the power supply. Follow all installation instructions supplied with the remote strobe light heads to determine how the cables connect to the strobe heads. PSE offers a variety of strobe light head options that can be powered by the PSE235.

2. After the cables have been properly routed for each strobe head they will have to be terminated with the three pin AMP socket housings provided. The cables are factory terminated with the proper AMP crimp pins for insertion into the housings, see Figure 2. If there is a need to re-terminate any wires, Figure 2 also includes stripping and crimping information.

NOTE: USE AMP HAND TOOL PART NO. 90124-2 OR EQUIVALENT TO CRIMP SOCKET PINS TO THE WIRES.

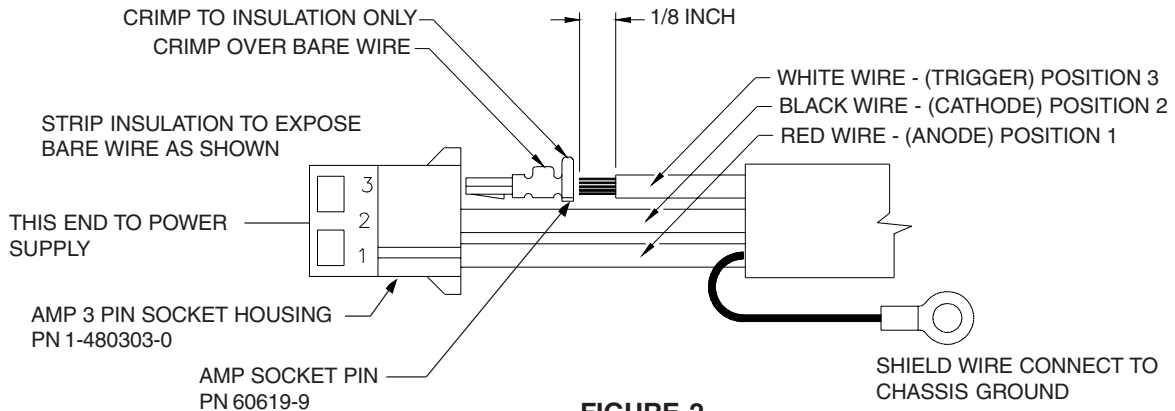

FIGURE 2

WARNING! It is very important to observe the pin locations and color on the AMP three pin socket housings. Improper connections could damage the remote strobe heads, see Figure 3.

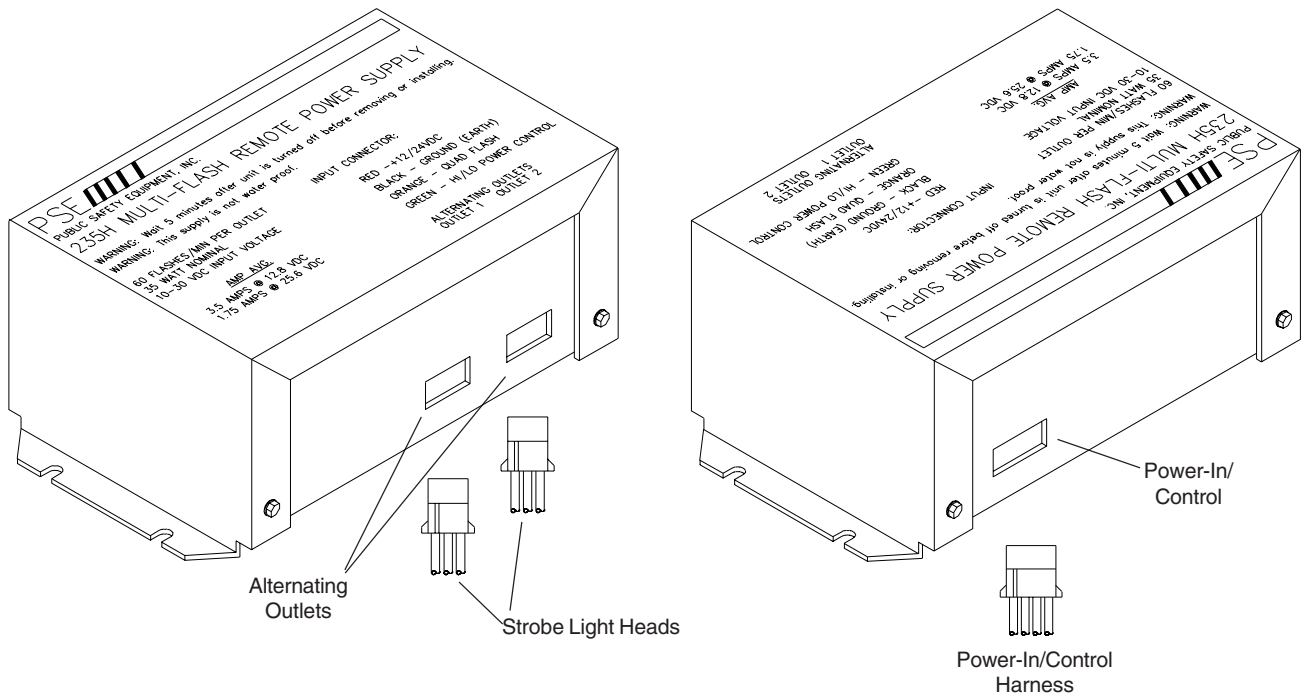

FIGURE 3

3. With the AMP 3 pin connectors terminated properly , plug each cable into the appropriate 3 position socket on the PSE235 strobe power supply, see Figure 3, page 5.

POWER-INPUT WIRE HARNESS ASSEMBLY

The Power-input/Control harness is to be connected to the 4-position socket connector on the PSE235 strobe power supply. See Figure 3, page 5. The Power-input/Control harness is to be connected to customer supplied wiring and a customer supplied switch to complete the installation.

The Power/Control Harness consists of (See Figure 4):

Red - Power input wire. This wire is to be connected to the power source of +12/24VDC. This is a **High-Current** input. When connected the power supply will be powered-up in Double Flash mode.

NOTE: The red power wire must be connected to the power source, directly or through an appropriately rated switch, for the power supply to operate.

Black - Ground/Earth wire. This wire is to be connected to a solid ground or the Negative terminal of the battery.

Orange - Quad Flash mode wire. This wire is to be connected to +12/24VDC for the Quad Flash mode. This is a low current input. When connected to +12/24VDC it will override the Double Flash mode.

Green - Hi/Lo power control wire. This wire when connected to +12/24VDC will place the power supply into low power mode. If not connected the power supply will be in high power mode. It is recommended that this wire be removed from the harness if Lo power mode will not be used. This is a low current input.

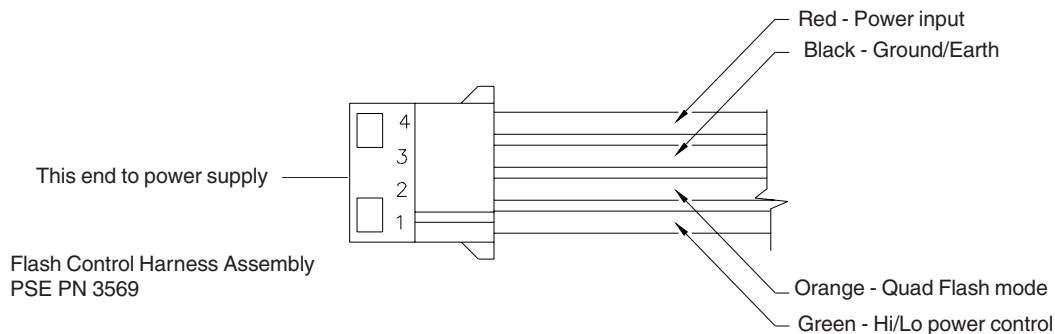
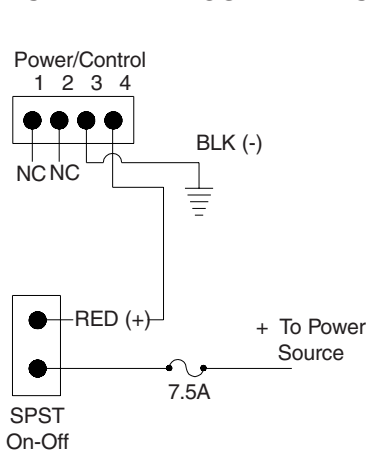

FIGURE 4

Switching Control Variations and Connections

The following diagrams show some of the wiring configurations possible for the various flash modes available with the Model PSE235 strobe power supply. All fuses shown are to be customer supplied, and recommended fuse ratings are to be observed. All switches are to be customer supplied.

VARIATIONS IN THE STANDARD DOUBLE FLASH MODE



ON-OFF SWITCHING HIGH POWER

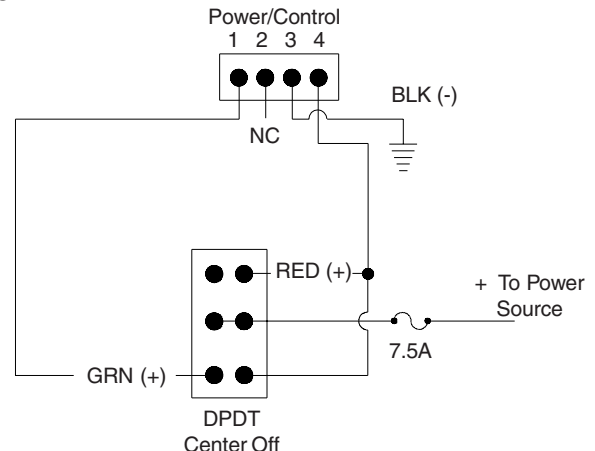

HIGH POWER-OFF-LOW POWER

VARIATIONS IN QUAD FLASH MODE

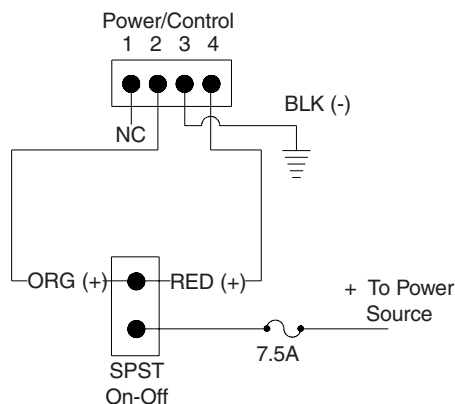

ON-OFF SWITCHING HIGH POWER

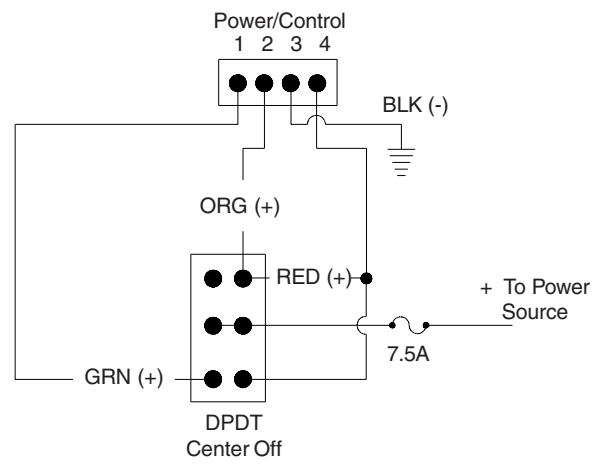

HIGH POWER-OFF-LOW POWER

MULTIPLE FLASH MODES

By selecting the proper switching both flash modes can be used. This is an example of using one switch to allow selection of either Double Flash mode or Quad Flash mode.

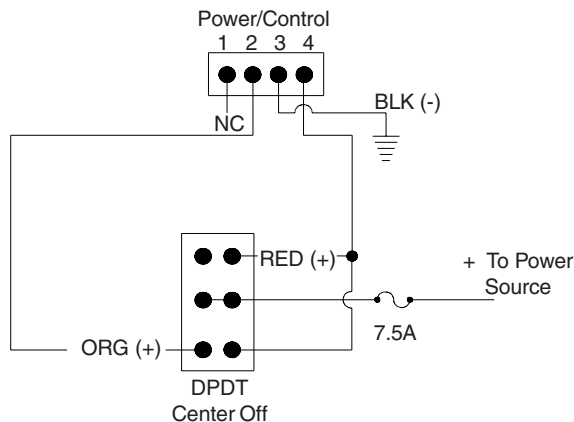

ON-OFF-ON SWITCHING HIGH POWER

Maintenance

The PSE235 Remote Strobe Power Supply has been designed to provide trouble free service. In case of difficulty, refer to the troubleshooting section. Periodic inspection of power supply wiring, and strobe light head connections for shorted or open wires will assure trouble free operation. The primary cause of short circuits has been found to be wires passing through firewalls, roofs, etc.

Troubleshooting

All PSE235 Remote Strobe Power Supply units are thoroughly tested before shipment. However, should you encounter a problem during installation or during the life of the product, refer to the guide below for information on troubleshooting. In most cases problems that occur will be related either to the power/control wiring, or to the strobe light head connection cables. In the event that the strobe power supply is at fault return the unit to the factory for service. Additional information may be obtained from the factory technical help line at 314-426-2700 ext. 2132.

TROUBLESHOOTING GUIDE

PROBLEM	CAUSE	SOLUTION
Internal fuse blows	<ul style="list-style-type: none"> a. Power input wires reversed. b. Power supply failure. c. Incorrect fuse size. 	<ul style="list-style-type: none"> a. Check power connections. b. Return for service. c. Replace with 7.5 AMP ATO (See fuse replacement section)
Light heads do not flash	<ul style="list-style-type: none"> a. Cable connections loose at power supply or light heads. b. Cable to light heads damaged and shorting to chassis. c. Cable terminated improperly in 3-pin AMP housing. d. Failed strobe light head. 	<ul style="list-style-type: none"> a. Check all connections. b. Check all cables for damage. c. Check wire orientations at 3-pin AMP connectors. d. Replace strobe light head.
Incorrect flash pattern	<ul style="list-style-type: none"> a. Control harness wiring and or switches not connected properly. 	<ul style="list-style-type: none"> a. Check wiring/switches. Refer to the Switching Variations and Connections section.
Low strobe light intensity	<ul style="list-style-type: none"> a. Power supply in low power mode. 	<ul style="list-style-type: none"> a. Check green wire on power harness. It should not be connected +12/24VDC for high power mode. Remove if low power mode not used.

INTERNAL FUSE REPLACEMENT

In the event that is determined the internal fuse needs to be replaced, the following procedure should be used (See Figure 5):

1. Remove the light head cables and power harness from the power supply.
2. Remove the four #8 sheet metal mounting screws and power supply.
3. Remove the four 1/4" hex head screws holding the cover to the chassis.
4. Remove the cover from the chassis.
5. Replace the 7.5 AMP ATO style fuse.
6. Assemble the cover and chassis and re-install the power supply.

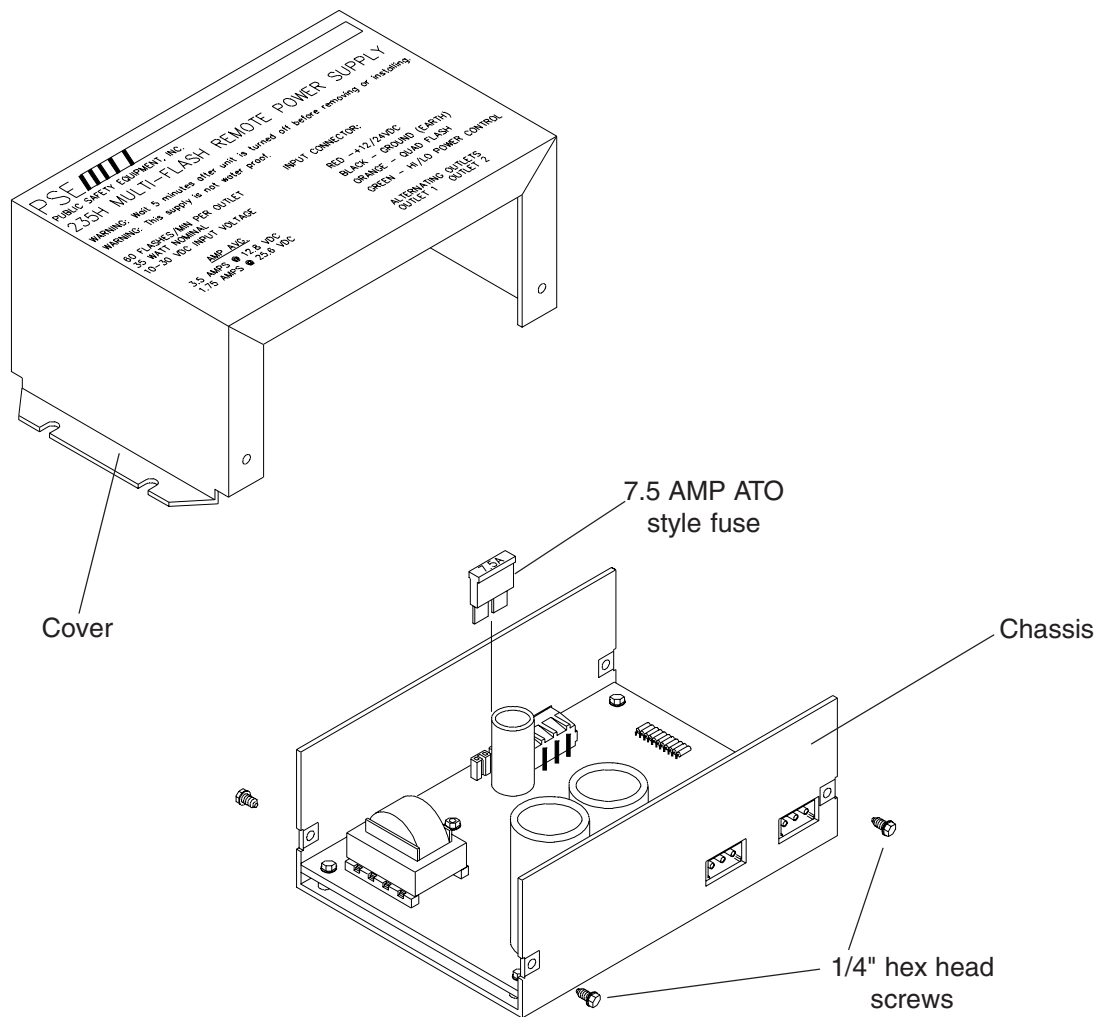

FIGURE 5

WARRANTY

This product was tested and found to be operational at the time of manufacture. Provided this product is installed and operated in accordance with the manufacturer's recommendations, Code 3, Inc. guarantees the PSE235 for a period of 2 years from the date of purchase or delivery, whichever is later. Units demonstrated to be defective within the warranty period will be repaired or replaced at the factory service center at no cost.

Use of a lamp or other electrical load of a wattage higher than installed or recommended by the factory, or use of inappropriate or inadequate wiring or circuit protection causes this warranty to become void. Failure or destruction of the product resulting from abuse or unusual use and/or accidents is not covered by this warranty. Use of non-PSE components and assemblies may cause damage to the system and/or personal injury, and voids all warranties on PSE systems and components.

Code 3, Inc. shall in no way be liable for other damages including consequential, indirect or special damages whether loss is due to negligence or breach of warranty.

CODE 3, INC. MAKES NO OTHER EXPRESS OR IMPLIED WARRANTY INCLUDING, WITHOUT LIMITATION, WARRANTIES OF FITNESS OR MERCHANTABILITY, WITH RESPECT TO THIS PRODUCT.

PRODUCT RETURNS

If a product must be returned for repair or replacement*, please contact our factory to obtain a Return Goods Authorization Number (RGA number) before you ship the product to Code 3, Inc. Write the RGA number clearly on the package near the mailing label. Be sure you use sufficient packing materials to avoid damage to the product being returned while in transit.

*Code 3, Inc. reserves the right to repair or replace at its discretion. Code 3, Inc. assumes no responsibility or liability for expenses incurred for the removal and /or reinstallation of products requiring service and/or repair.; nor for the packaging, handling, and shipping; nor for the handling of products return to sender after the service has been rendered.

NEED HELP? Call our Technical Assistance Hotline - (314) 996-2800

Code 3,® Inc., a subsidiary of
Public Safety Equipment, Inc.

**CODE 3**[®]
PSE
PUBLIC SAFETY EQUIPMENT, INC.

Code 3, Inc.
10986 N. Warson Road
St. Louis, Missouri 63114-2029—USA
www.code3pse.com