

# INSTALLATION & OPERATION MANUAL

SUPERVISOR™

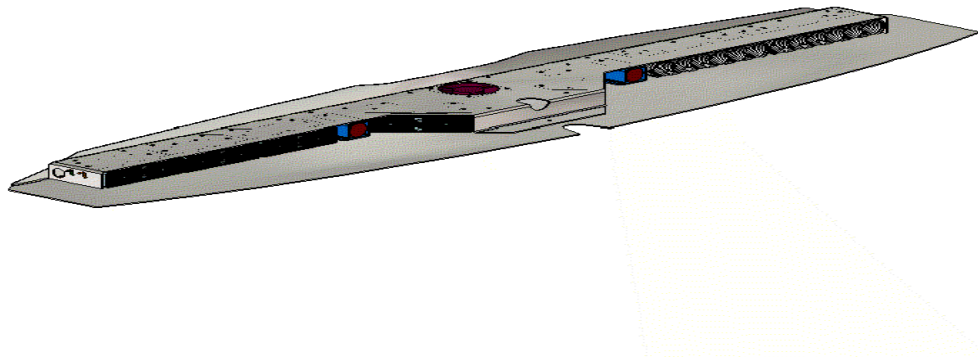

**CODE 3**<sup>®</sup>  
A PUBLIC SAFETY EQUIPMENT COMPANY

## SuperVisor™ Interior Lighting System CHEVROLET IMPALA

### CONTENTS:

Introduction .....	2
Unpacking & Pre-Installation .....	3
Installation & Mounting .....	3-7
Wiring Diagram & Instructions .....	8-9
Fusing and MR8 Lamp Installation .....	10
LED Flash pattern selection & Troubleshooting .....	11
Exploded View & Parts List .....	12
Warranty .....	16

For future reference record your product's serial no. here \_\_\_\_\_

**IMPORTANT:** *Read all instructions and warnings before installing and using.*  
**INSTALLER:** *This manual must be delivered to the end user of this equipment.*

# Introduction

The SuperVisor™ is an interior lighting system that fits in the visor area near the top of the windshield. It delivers an amazing warning signal, including MR8 powered takedown lights.

The SuperVisor is designed on a modular basis, which means that the light bar can be customized to meet most any requirements. The SuperVisor has room for up to eight LED lighthead plus two MR8 takedowns. Each lighthead is individually wired for any flash pattern or combination of flash patterns required.

The use of this or any warning device does not ensure that all drivers can or will observe or react to an emergency warning signal. Never take the right-of-way for granted. It is your responsibility to be sure you can proceed safely before entering an intersection, driving against traffic, responding at a high rate of speed, or walking on or around traffic lanes.

The effectiveness of this warning device is highly dependent upon correct mounting and wiring. Read and follow the manufacturer's instructions before installing or using this device. The vehicle operator should insure daily that all features of the device operate correctly. In use, the vehicle operator should insure the projection of the warning signal is not blocked by vehicle components (i.e.: open trunks or compartment doors), people, vehicles, or other obstructions.

This equipment is intended for use by authorized personnel only. It is the user's responsibility to understand and obey all laws regarding emergency warning devices. The user should check all applicable city, state and federal laws and regulations.

Code 3, Inc., assumes no liability for any loss resulting from the use of this warning device.

Proper installation is vital to the performance of this warning device and the safe operation of the emergency vehicle. It is important to recognize that the operator of the emergency vehicle is under psychological and physiological stress caused by the emergency situation. The warning device should be installed in such a manner as to: A) Not reduce the output performance of the system, B) Place the controls within convenient reach of the operator so that he can operate the system without losing eye contact with the roadway.

Emergency warning devices often require high electrical voltages and/or currents. Properly protect and use caution around live electrical connections. Grounding or shorting of electrical connections can cause high current arcing, which can cause personal injury and/or severe vehicle damage, including fire.

Any electronic device may create or be affected by electromagnetic interference. After installation of any electronic device operate all equipment simultaneously to insure that operation is free of interference. Never power emergency warning equipment from the same circuit or share the same grounding circuit with radio communication equipment.

**PROPER INSTALLATION COMBINED WITH OPERATOR TRAINING IN THE PROPER USE OF EMERGENCY WARNING DEVICES IS ESSENTIAL TO INSURE THE SAFETY OF EMERGENCY PERSONNEL AND THE PUBLIC.**

All devices should be mounted in accordance with the manufacturer's instructions and securely fastened to vehicle elements of sufficient strength to withstand the forces applied to the device. Driver and/or passenger airbags (SRS) will affect the way equipment should be mounted. This device should be mounted by permanent installation and within the zones specified by the vehicle manufacturer, if any. Any device mounted in the deployment area of an air bag will damage or reduce the effectiveness of the air bag and may damage or dislodge the device. Installer must be sure that this device, its mounting hardware and electrical supply wiring does not interfere with the air bag or the SRS wiring or sensors. Mounting the unit inside the vehicle by a method other than permanent installation is not recommended as unit may become dislodged during swerving, sudden braking or collision. Failure to follow instructions can result in personal injury.



**WARNING!**

## Unpacking & Pre-installation

Carefully remove the SuperVisor™ and place it on a flat surface, taking care not to scratch the lenses or damage the cable coming out of the side. Examine the unit for transit damage, broken lamps, etc. Report any damage to the carrier and keep the shipping carton.

Standard light bars are built to operate on 12 volt D.C. negative ground (earth) vehicles. If you have an electrical system other than 12 volt D.C. negative ground (earth), and have not ordered a specially wired light bar, contact the factory for instructions.

Test the unit before installation. To test, touch the black, (and if present grey, purple, and brown) wire(s) to the ground (earth) and the other wires to +12 volts D.C., in accordance with the instructions attached to the cable (an automotive battery is preferable for this test). A battery charger may be used, but please note that some electronic options (flashers, stingrays, etc.) may not operate normally when powered by a battery charger. If problems occur at this point, contact the factory.

## Installation & Mounting

### WARNING!



Utilizing non-factory supplied screws and/or mounting brackets and/or the improper number of screws may result in loss of warranty coverage on the equipment.

**Mounting Hardware** - All mounting hardware is packed in a small box inside the main carton. There are four brackets used to mount the visor bar to the vehicle. These are discussed in detail later.

### Removing Sun Visors

Begin the installation by removing the Chevrolet Impala's driver and passenger sun visors. Identify each visor with tape or other marking to indicate the driver from the passenger side unit. They are not identical. There are three screws that hold the pivotal arm of the sun visor to the headliner. Remove the two outer screws using a small torx screwdriver. Then unclip the sun visor and rotate it over to expose the last screw as shown in Figure 1.



**FIGURE 1**

## Attach brackets to sun visor retaining clips

In order to remove the sun visor retaining clip, unscrew the one torx screw holding it in place. Place the inner bracket on the retaining clip as shown in Figure 2. Attach the inner bracket and retaining clip to the headliner as illustrated in Figure 3. Do not completely tighten the screw at this time.



FIGURE 2



FIGURE 3

## Attaching the pivot arm brackets

Attach the outer brackets that are supplied noting the difference between passenger and driver side brackets. Position the driver's side bracket on the driver's side sun visor's pivot arm as shown in Figure 4. Attach the driver's side bracket to the headliner with the inner torx screw as shown in figure 5. Next, move the sun visor over to gain access to install the other two torx screws. Do not tighten the screws at this time. Repeat the same procedure to attach the passenger's side outer bracket.



FIGURE 4



FIGURE 5

## Mounting the SuperVisor™

Before mounting the SuperVisor, apply gasket stripping to the front edge of the lower chassis in order to prevent scratching the windshield. See Figure 6. Once all four brackets and sun visors are attached, the SuperVisor is now ready to be installed. Position the SuperVisor in the center of the windshield as shown in Figure 7.



FIGURE 6



FIGURE 7

## Mounting the SuperVisor™ (continued)

The two center brackets should line up with the holes in the SuperVisor's lower chassis. Using the supplied 1/4"-20 bolts and the internal tooth lock washers, loosely install them as shown in Figure 8.



**FIGURE 8**

Next, if necessary, slightly loosen the three pivot arm bracket retaining screws in order to align the pivot arm bracket's hole with the mating chassis hole on the end of the SuperVisor. Finally, thread the supplied bolts and internal tooth lock washers through the pivot arm bracket's hole into the hole on the end of the chassis, shown in Figure 9. Tighten all visor mounting torx screws. Next using a tape measure and a level, center the SuperVisor from side to side and locate a position on the headliner where the SuperVisor is level. Finally, tighten all four bolts securely. Do not overtighten.

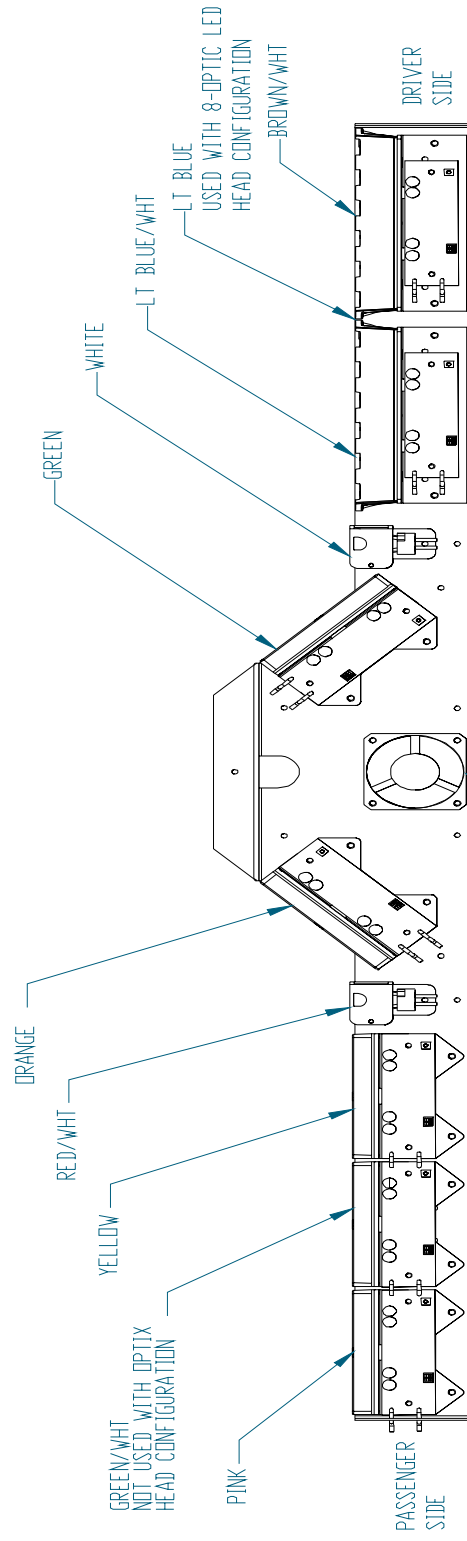

**FIGURE 9**

**Note:** Figure 8 and 9 brackets are excellent hard mounting points for radar guns, video cameras, or etc.

**Caution:** Drilling into the housing of the light bar could damage internal wiring, circuitry, or other internal components.

# Wiring Diagram



BLACK = NEGATIVE GROUND  
 BROWN = NOT USED  
 PURPLE = NOT USED

FUSE SIZE CALCULATION:  
 USE 1.5 AMP FOR EACH LED HEAD  
 USE 6.3 AMP FOR THE MR8 HEADS AND FAN

RED FAN MUST BE WIRED TO OPERATE CONTINUOUSLY WHENEVER THE MR-8 LIGHTS ARE IN OPERATION EITHER FLASHING OR STEADY BURN



# Wiring Instructions



Larger wires and tight connections will provide longer service life for components. For high current wires it is highly recommended that terminal blocks or soldered connections be used with shrink tubing to protect the connections. Do not use insulation displacement connectors (e.g. 3M<sup>®</sup> Scotchlock type connectors). Route wiring using grommets and sealant when passing through compartment walls. Minimize the number of splices to reduce voltage drop. High ambient temperatures (e.g. underhood) will significantly reduce the current carrying capacity of wires, fuses, and circuit breakers. Use "SXL" type wire in engine compartment. All wiring should conform to the minimum wire size and other recommendations of the manufacturer and be protected from moving parts and hot surfaces. Looms, grommets, cable ties, and similar installation hardware should be used to anchor and protect all wiring. Fuses or circuit breakers should be located as close to the power takeoff points as possible and properly sized to protect the wiring and devices. Particular attention should be paid to the location and method of making electrical connections and splices to protect these points from corrosion and loss of conductivity. Ground terminations should only be made to substantial chassis components, preferably directly to the vehicle battery. The user should install a fuse sized to approximately 125% of the maximum Amp capacity in the supply line to protect against short circuits. For example, a 30 Amp fuse should carry a maximum of 24 Amps. **DO NOT USE 1/4" DIAMETER GLASS FUSES AS THEY ARE NOT SUITABLE FOR CONTINUOUS DUTY IN SIZES ABOVE 15 AMPS.** Circuit breakers are very sensitive to high temperatures and will "false trip" when mounted in hot environments or operated close to their capacity.

Route the wiring cable into the passenger compartment as shown in Figure 10. It is advisable to leave an extra loop of cable when installing the light bar to allow for future changes or reinstallations. Connect the black lead to a solid frame ground (earth), preferably, the (-) or ground (earth) side of the battery, and the remaining power wires to the +12V terminal of the battery, power switches, siren or RLS controller. The MR8 takedowns may be installed to a flasher. The fan should be wired to operate continuously whenever the takedowns are in operation, either flashing or steady burn. Each light head is wired independently to allow complete flexibility of control.



**FIGURE 10**

## LED Fusing Considerations

Although the average current draw per module is very low, due to the type of circuit used to power each module, the instantaneous peak current to a module can be significantly higher during low voltage conditions. To avoid prematurely blowing ATO style fuses or tripping breakers it is recommended the following rule-of-thumb be used to size fuses or breakers. This is especially important in light bars with many LED modules running off a single fused source,

### Minimum fuse size calculation:

#### For LED 12 volt electrical current only

1.5 x (number of modules being fused)

Example: 2 intersection modules and 6 directional modules.

Minimum fuse requirement for single fuse -  $1.5 (8) = 12 \text{ A}$

#### For MR8 takedown and fan 12 volt electrical current only

Total wattage (1 MR8's = 35W, fan = 5W) divided 12volts = Amperage

Example: 2 MR8's and 1 fan =  $(75\text{W}/12) = 6.25 \text{ A}$

#### Total 12 volt electrical current

$12\text{A (for LED's)} + 6.25\text{A (for MR8's and fan)} = 18.25 \text{ A}$

## Product Features

LED-X light head options:	Red, Blue, Amber, White; Directional or Wide Optics; Flashing or Steady Burn Control
6 LED Optix light head options:	Red, Blue, Amber, White; Directional or Wide Optics; Flashing or Steady Burn Control
3 LED Optix light head options:	Red, Blue, Amber, White; Directional, Wide or Hybrid Optics; Flashing or Steady Burn Control
33 Optix light head options:	Two 3-LED Heads with one 6-LED Optic Red, Blue, Amber, White; Directional, Wide or Hybrid Optics; Flashing or Steady Burn Control
LC-LED light head options:	Red, Blue, Amber; Flashing or Steady Burn Control

MR8 Specs: 35w Halogen with 13° spot  
Size: 45.50" long x 2.18" tall x 7.95" deep  
Weight: 7.5lb

### WARNING!



This Product contains high intensity LED devices. To prevent eye damage, DO NOT stare into light beam at close range.

## MR8 Takedown Light Assembly

Refer to Figure 13 for lamp replacement. Remove the lamp assembly from the product by disconnecting the two electrical wires and removing the appropriate fastener. Remove the fastener clamping the lamp and then remove the lamp from the mounting bracket. Disconnect the lamp from the ceramic connector and reinstall a new lamp. The lamp lens should be cleaned to remove fingerprints then reinstall the lamp assembly in the light bar and reconnect the electrical wires. Reassemble the components in reverse order.

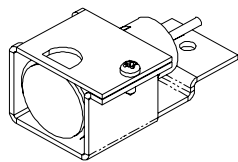

FIGURE 13



### WARNING!

Lamps are extremely hot! Allow to cool completely before attempting to remove. Gloves and eye protection should be worn when handling halogen lamps as they are pressurized and accidental breakage can result in flying glass.

## Directional module Flash Pattern - Table 2

CycleFlash (DEFAULT)  
 NFPA QuadFlash75  
 Steadyburn  
 ModelFlash  
 ActiveFlash  
 FiveFlash70  
 QuadFlash70  
 TripleFlash70  
 DoubleFlash70  
 SingleFlash75

Quad Pop Flash75  
 Triple Pop Flash75  
 SingleFlash375  
 SingleFlash250  
 SingleFlash150  
 FiveFlash150  
 QuadFlash150  
 DoubleFlash150  
 TripleFlash150

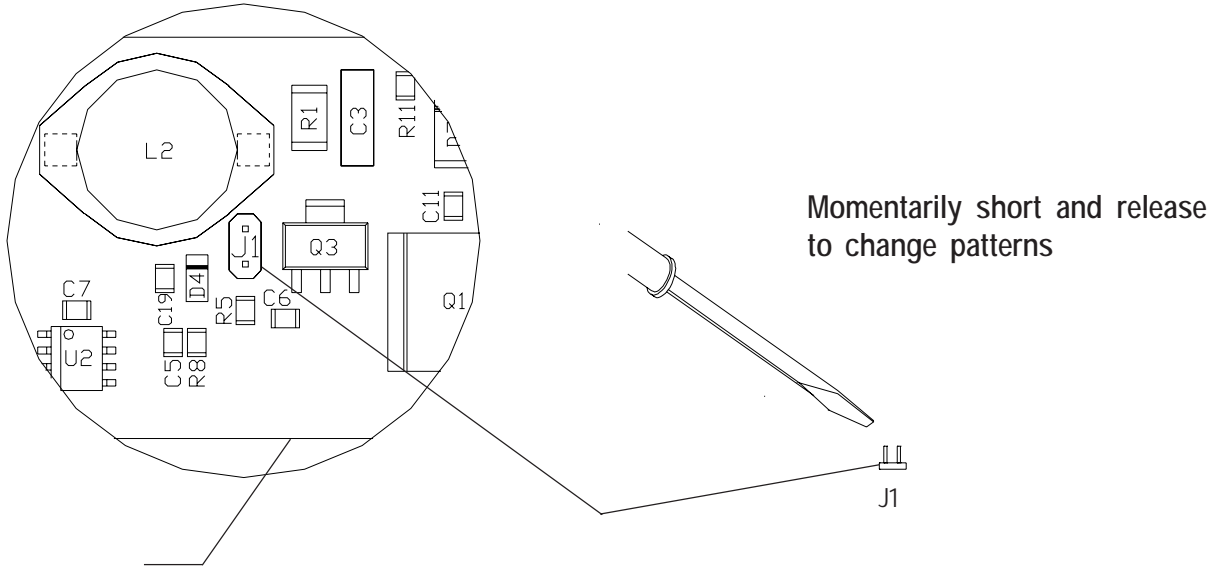

**Flash Pattern Header for OPTIX/LEDX**

## Troubleshooting

All SuperVisors are thoroughly tested prior to shipment. However, should you encounter a problem during installation or during the life of the product, follow the guide below for information on repair and troubleshooting. Additional information may be obtained from the factory technical help line at 314-996-2800.

Follow the guide below for information on repair and troubleshooting.

### TROUBLESHOOTING GUIDE

**Note:** LED modules must be replaced as a module. There are no user serviceable parts.

PROBLEM	QUESTIONS	POSSIBLE CAUSE	SOLUTION
LED module not operating when powered.	N/A	a. Bad power/ground connection. b. Defective module.	a. Fix connection. b. Replace module

# Parts List

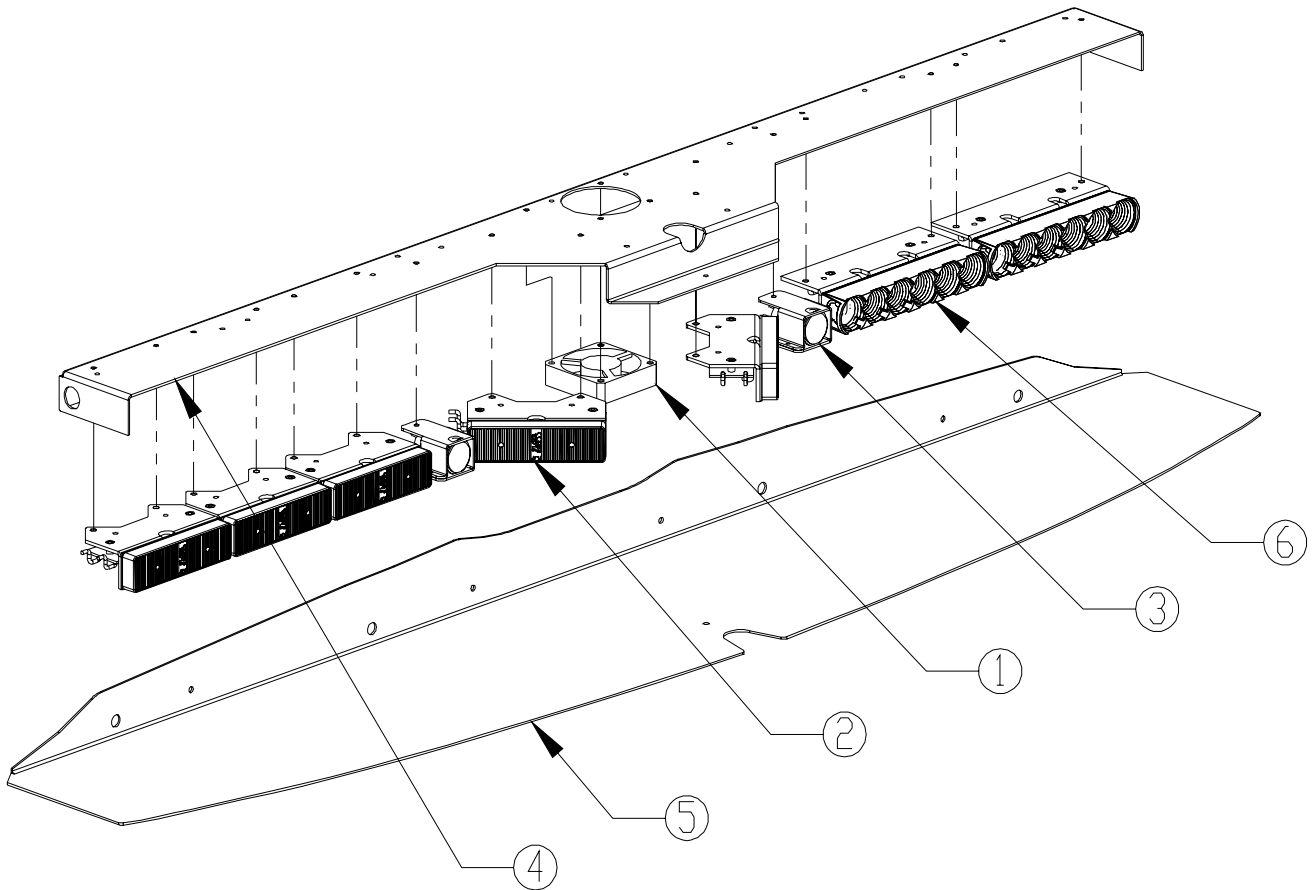

<u>Reference Number</u>	<u>Part Description</u>	<u>Part Number</u>
1	+12V Cooling Fan	T05612
2	*LEDX LED Module	*Contact Code 3, Inc for P/N
3	MR8 lamp	T09600
4	Chassis	T09614
5	Outer Panel	S51410
6	*Optix LED Module	*Contact Code 3, Inc for P/N
Not Shown	Inner Mtg. Brkt. Impala	T09615
Not Shown	Outer Mtg. Brkt. Impala Pass.	T09617
Not Shown	Outer Mtg. Brkt. Impala Dr.	T09616

## Notes

## Notes

## Notes

# WARRANTY

Code 3, Inc.'s emergency devices are tested and found to be operational at the time of manufacture. Provided they are installed and operated in accordance with manufacturer's recommendations, Code 3, Inc. guarantees all parts and components except the lamps to a period of 1 year, LED Lighthead modules to a period of 5 years (unless otherwise expressed) from the date of purchase or delivery, whichever is later. Units demonstrated to be defective within the warranty period will be repaired or replaced at the factory service center at no cost.

Use of lamp or other electrical load of a wattage higher than installed or recommended by the factory, or use of inappropriate or inadequate wiring or circuit protection causes this warranty to become void. Failure or destruction of the product resulting from abuse or unusual use and/or accidents is not covered by this warranty. Code 3, Inc. shall in no way be liable for other damages including consequential, indirect or special damages whether loss is due to negligence or breach of warranty.

**CODE 3, INC. MAKES NO OTHER EXPRESS OR IMPLIED WARRANTY INCLUDING, WITHOUT LIMITATION, WARRANTIES OF FITNESS OR MERCHANTABILITY, WITH RESPECT TO THIS PRODUCT.**

# PRODUCT RETURNS

If a product must be returned for repair or replacement\*, please contact our factory to obtain a Return Goods Authorization Number (RGA number) before you ship the product to Code 3, Inc. Write the RGA number clearly on the package near the mailing label. Be sure you use sufficient packing materials to avoid damage to the product being returned while in transit.

\*Code 3, Inc. reserves the right to repair or replace at its discretion. Code 3, Inc. assumes no responsibility or liability for expenses incurred for the removal and /or reinstallation of products requiring service and/or repair.; nor for the packaging, handling, and shipping; nor for the handling of products returned to sender after the service has been rendered.

**NEED HELP? Call our Technical Assistance HOTLINE - (314) 996-2800**

Code 3®, Inc.  
10986 N. Warson Road  
St. Louis, Missouri 63114-2029—USA  
Ph. (314) 426-2700 Fax (314) 426-1337  
[www.code3pse.com](http://www.code3pse.com)