

INSTALLATION & OPERATION MANUAL

SuperVisor®

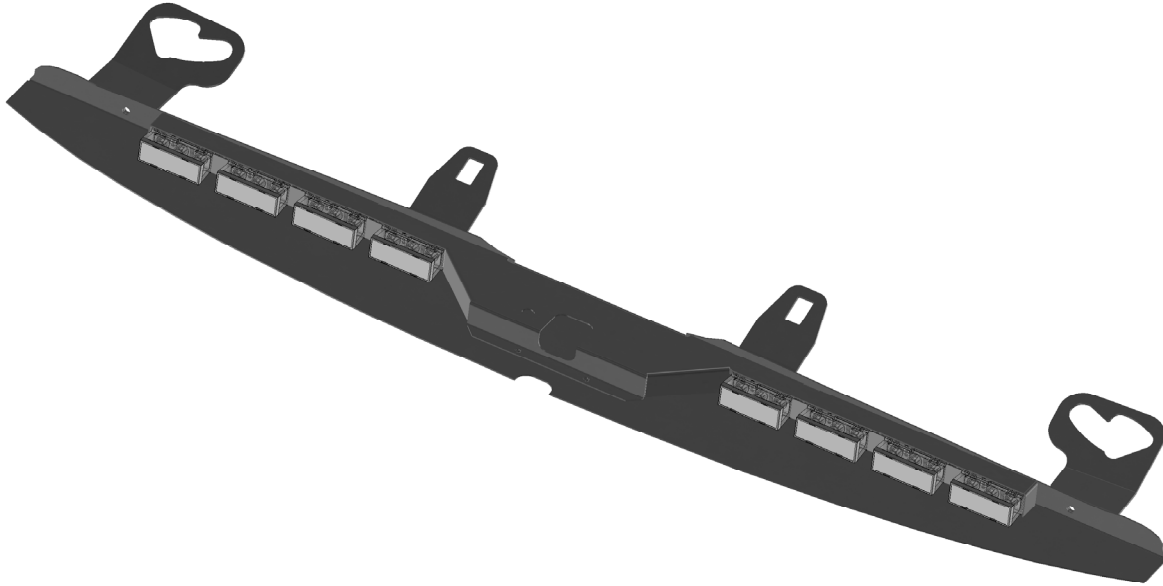

SuperVisor® with Tri-Core® Technology

U.S. Patent Nos. 7,153,015 and 7,300,175, Other Patents Pending

Interior Lighting System

Chevy Tahoe

2009 Model

CONTENTS:

Introduction	2
Unpacking & Pre-Installation	2
Installation & Mounting	3-5
Wiring Instructions - Flash Pattern Selection	5-7
Troubleshooting - Exploded View - Parts List	8
Notes	9-11
Warranty	12

For future reference record your product's serial no. here _____

IMPORTANT:

Read all instructions and warnings before installing and using.

INSTALLER: *This manual must be delivered to the end user of this equipment.*

Introduction

The SuperVisor® with TriCore® Technology is an interior lighting system that fits in the visor area near the top of the windshield. The SuperVisor has room for up to eight TriCore light heads.

Product Features

TriCore® light head options: Red, Blue, Amber, and White-----Flashing or Steady Burn Control
Size: 50.00" long x 1.54" tall x 5.25" deep-----Weight: 7.5 lbs

The use of this or any warning device does not ensure that all drivers can or will observe or react to an emergency warning signal. Never take the right-of-way for granted. It is your responsibility to be sure you can proceed safely before entering an intersection, driving against traffic, responding at a high rate of speed, or walking on or around traffic lanes. The effectiveness of this warning device is highly dependent upon correct mounting and wiring. Read and follow the manufacturer's instructions before installing or using this device. The vehicle operator should insure daily that all features of the device operate correctly. In use, the vehicle operator should insure the projection of the warning signal is not blocked by vehicle components (i.e.: open trunks or compartment doors), people, vehicles, or other obstructions. This equipment is intended for use by authorized personnel only. It is the user's responsibility to understand and obey all laws regarding emergency warning devices. The user should check all applicable city, state and federal laws and regulations. Code 3, Inc., assumes no liability for any loss resulting from the use of this warning device. Proper installation is vital to the performance of this warning device and the safe operation of the emergency vehicle. It is important to recognize that the operator of the emergency vehicle is under psychological and physiological stress caused by the emergency situation. The warning device should be installed in such a manner as to: A) Not reduce the output performance of the system, B) Place the controls within convenient reach of the operator so that he can operate the system without losing eye contact with the roadway. Emergency warning devices often require high electrical voltages and/or currents. Properly protect and use caution around live electrical connections. Grounding or shorting of electrical connections can cause high current arcing, which can cause personal injury and/or severe vehicle damage, including fire. Any electronic device may create or be affected by electromagnetic interference. After installation of any electronic device operate all equipment simultaneously to insure that operation is free of interference. Never power emergency warning equipment from the same circuit or share the same grounding circuit with radio communication equipment. All devices should be mounted in accordance with the manufacturer's instructions and securely fastened to vehicle elements of sufficient strength to withstand the forces applied to the device. Driver and/or passenger air bags (SRS) will affect the way equipment should be mounted. This device should be mounted by permanent installation and within the zones specified by the vehicle manufacturer, if any. Any device mounted in the deployment area of an air bag will damage or reduce the effectiveness of the air bag and may damage or dislodge the device. Installer must be sure that this device, its mounting hardware and electrical supply wiring does not interfere with the air bag or the SRS wiring or sensors. Mounting the unit inside the vehicle by a method other than permanent installation is not recommended as unit may become dislodged during swerving, sudden braking or collision. Failure to follow instructions can result in personal injury. **PROPER INSTALLATION COMBINED WITH OPERATOR TRAINING IN THE PROPER USE OF EMERGENCY WARNING DEVICES IS ESSENTIAL TO INSURE THE SAFETY OF EMERGENCY PERSONNEL AND THE PUBLIC.**



Unpacking & Pre-installation

Carefully remove the SuperVisor and place it on a flat surface, taking care not to scratch the lenses or damage the cable coming out of the top. Examine the unit for transit damage, broken lamps, etc. Report any damage to the carrier and keep the shipping carton.

Standard light bars are built to operate on 12 volt D.C. negative ground (earth) vehicles. If you have an electrical system other than 12 volt D.C. negative ground (earth), and have not ordered a specially wired light bar, contact the factory for instructions.

Test the unit before installation. To test, touch the black wire to the ground (earth) and the other wires to +12 volts D.C., in accordance with the instructions attached to the cable (an automotive battery is preferable for this test). A battery charger may be used, but note that some electronic options may not operate normally when powered by a battery charger. If problems occur at this point, contact the factory.

Note: Before beginning the installation process, be absolutely certain that the Light Bar functions as desired (See page 7 for options)!

WARNING!



Utilizing non-factory supplied screws and/or mounting brackets and/or the improper number of screws may result in loss of warranty coverage on the equipment.

Mounting Hardware - All mounting hardware is packed in a small bag inside the main carton. There are four brackets used to mount the SuperVisor to the vehicle. These are discussed in detail later.

Step 1-Removing Sun Visors

Begin the installation by removing the driver and passenger sun visors. Identify each visor with tape or other marking to indicate the driver from the passenger side unit; they are not always identical. First remove the plastic visor pivot bracket cover by prying the cover apart at the thin slit shown in Figure 1 with a thin instrument like a putty knife. There are small keeper tabs which hold the cover to the pivot bracket (Figure 2 shows the locations of the tabs). You have to pry the slit open and pull the cover down and away from the headliner at the same time. It helps to pull the edge of the cover outward and down in the area of each tab to help release the cover from the pivot bracket. When one of the tabs is released, it is easier to release the cover at the other tab locations (Figure 3 shows the cover removed). Next there are three screws that hold the pivot arm bracket of the sun visor to the headliner. Remove the three screws using a small #15 Torx screwdriver as shown in Figure 4. The screws do not have to be completely removed from the plastic pivot arm bracket to release the pivot arm (see Figure 5). Unplug the visor vanity mirror light wire if the vehicle is so equipped (see Figure 6).



FIGURE 1



FIGURE 2



FIGURE 3



FIGURE 4

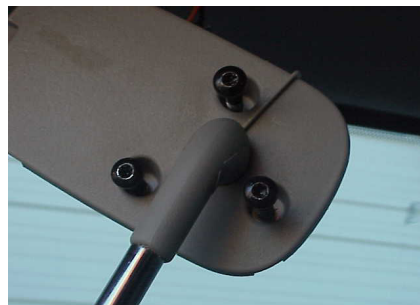

FIGURE 5



FIGURE 6

Step 2 Remove the visor retaining clips

Pry open the small cover on the sun visor retaining clip with a very small flat bladed screwdriver to gain access to the sun visor retaining clip screw (see Figures 7 and 8). Remove the single #15 Torx screw that holds each clip in place as shown in Figure 9.



FIGURE 7



FIGURE 8



FIGURE 9

Step 3 Attach the pivot arm brackets

Attach the outer mounting brackets that are supplied noting the difference between passenger and driver side brackets (see Figure 10 **Note: The Driver side is shown**). Rotate the pivot arm on the Driver's side sun visor and verify the orientation of the outer bracket as shown in Figure 11. Re Plug the wire terminal that goes to the visor mirror vanity light, if the vehicle is so equipped, and carefully tuck the wire and terminal back into the elongated slot in the headliner as you position the Driver's side pivot arm. Attach the three Torx screws as shown in Figure 12. Repeat this operation for the Passenger side pivot arm and outer mounting bracket. Leave the Torx screws slightly loose at this time.



FIGURE 10



FIGURE 11



FIGURE 12

Step 4 Attach brackets to sun visor retaining clips

Place the inner bracket on the retaining clip as shown in Figures 13 and 14. Attach the inner bracket and retaining clip to the headliner with the Torx screw as illustrated in Figure 15. Leave the Torx screws slightly loose at this time.



FIGURE 13



FIGURE 14



FIGURE 15

Step 5 Mounting the SuperVisor®

Once all four sun visor brackets are attached, the SuperVisor is ready to be installed. Tilt the rear view mirror down as far out of the way as possible (see Figure 16). Carefully move the SuperVisor into position above the rear view mirror by tilting one end up as shown in Figure 17 with the front outer tip of the SuperVisor located slightly in front of the corner post of the vehicle, then swing the other end up into position being very careful not to scratch the plastic corner post covers.

Line up the mounting holes in the outer mounting brackets with the threaded holes in the SuperVisor and thread the supplied 1/4"-20 bolts and internal tooth lock washers into the SuperVisor's Outer Panel (see Figure 18). Line up the mounting holes in the inner mounting brackets with the threaded holes in the SuperVisor and loosely thread the supplied 1/4"-20 bolts and internal tooth lock washers into the holes in the SuperVisor's Outer Panel as shown in Figure 19. Carefully tighten the three Torx screws in each of the two outer pivot brackets by tightening each screw a little at a time (see Figure 12). **Note: Tightening the three screws each a little at a time helps prevent cracking the OEM plastic pivot bracket.** Tighten the two Torx screws in the center inner mounting brackets (see Figure 15). Tighten the two 1/4-20 bolts in the Outer Mounting Brackets (see Figure 20). While pushing up firmly on the SuperVisor's Outer Panel to close up the gaps as much as possible between the SuperVisor's Outer Panel and the vehicle's headliner fabric, tighten the two 1/4-20 bolts at the inner mounting brackets (see Figure 21). Replace the plastic visor pivot bracket covers and snap the small inner visor clip covers closed.



FIGURE 16



FIGURE 17



FIGURE 18



FIGURE 19



FIGURE 20



FIGURE 21

The bracket fasteners make excellent hard mounting points for radar guns and video cameras etc.

Caution: Drilling into the housing of the light bar could damage wiring or other internal components.

Cable Routing Instructions

Route the wiring cable into the passenger compartment down the door post as shown in Figure 22 or as otherwise desired. It is advisable to leave an extra loop of cable when installing the light bar to allow for future changes or reinstallations.

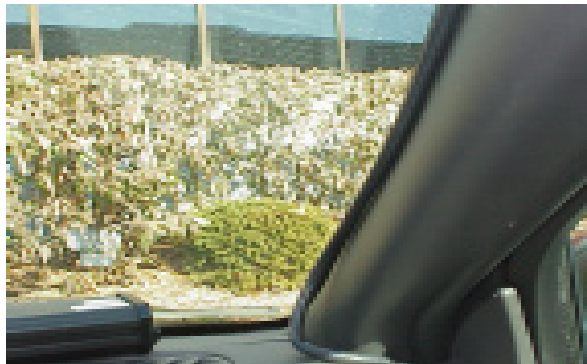

FIGURE 22

Wiring Instructions

Connect the black lead to a solid frame ground (earth), preferably the (-) or ground (earth) side of the battery, and the power wire to the +12V terminal of the battery. Connect the remaining wires as shown on page 6.



Larger wires and tight connections will provide longer service life for components. For high current wires it is highly recommended that terminal blocks or soldered connections be used with shrink tubing to protect the connections. Do not use insulation displacement connectors (e.g. 3M® Scotchlock type connectors). Route wiring using grommets and sealant when passing through compartment walls. Minimize the number of splices to reduce voltage drop. High ambient temperatures (e.g. under hood) will significantly reduce the current carrying capacity of wires, fuses, and circuit breakers. Use "SXL" type wire in engine compartment. All wiring should conform to the minimum wire size and other recommendations of the manufacturer and be protected from moving parts and hot surfaces. Looms, grommets, cable ties, and similar installation hardware should be used to anchor and protect all wiring. Fuses or circuit breakers should be located as close to the power takeoff points as possible and properly sized to protect the wiring and devices. Particular attention should be paid to the location and method of making electrical connections and splices to protect these points from corrosion and loss of conductivity. Ground terminations should only be made to substantial chassis components, preferably directly to the vehicle battery. The user should install a fuse sized to approximately 125% of the maximum Amp capacity in the supply line to protect against short circuits. For example, a 30 Amp fuse should carry a maximum of 24 Amps. **DO NOT USE 1/4" DIAMETER GLASS FUSES AS THEY ARE NOT SUITABLE FOR CONTINUOUS DUTY IN SIZES ABOVE 15 AMPS.** Circuit breakers are very sensitive to high temperatures and will "false trip" when mounted in hot environments or operated close to their capacity.

Wiring Diagram - NO TAKE DOWNS

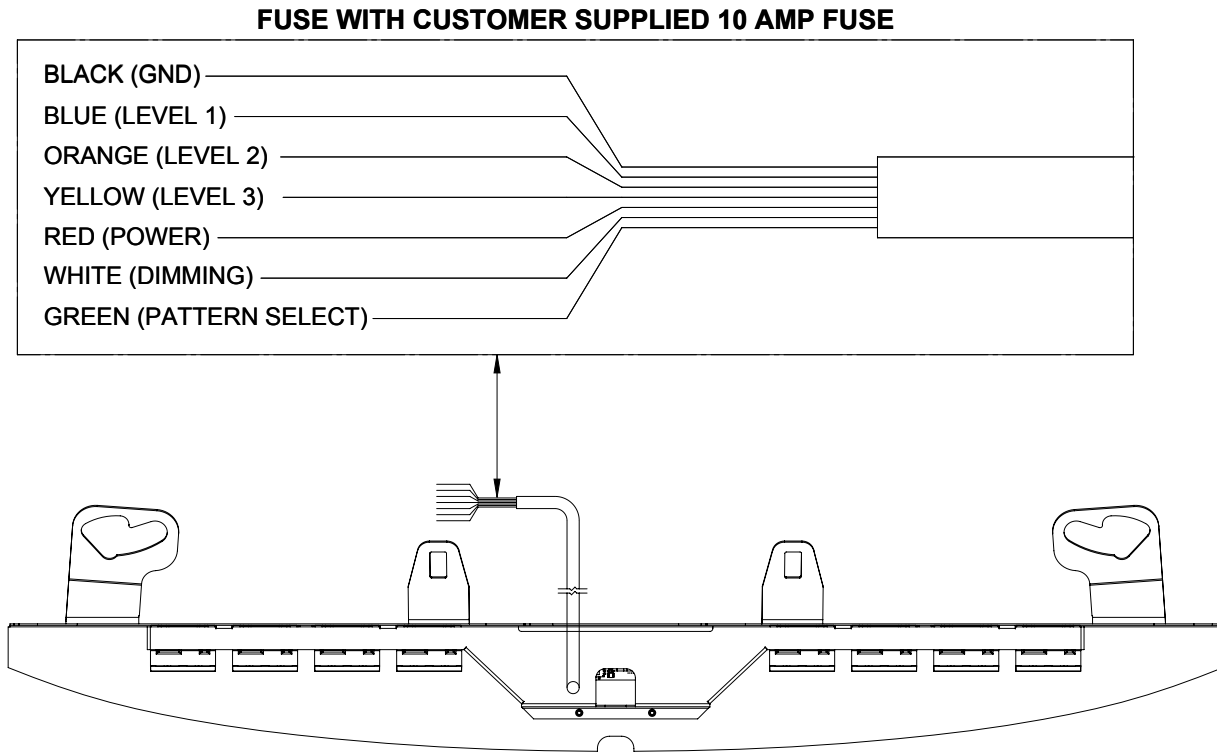

Wiring Diagram - WITH TAKE DOWNS

NOTE: FOR SUPERVISORS WITH TAKE DOWN OPTION CONTROL WIRES ARE AS SHOWN BELOW

THE TAKEDOWN STEADY(YELLOW) WIRE WILL OVERRIDE THE TAKEDOWN FLASH (ORANGE) WIRE.

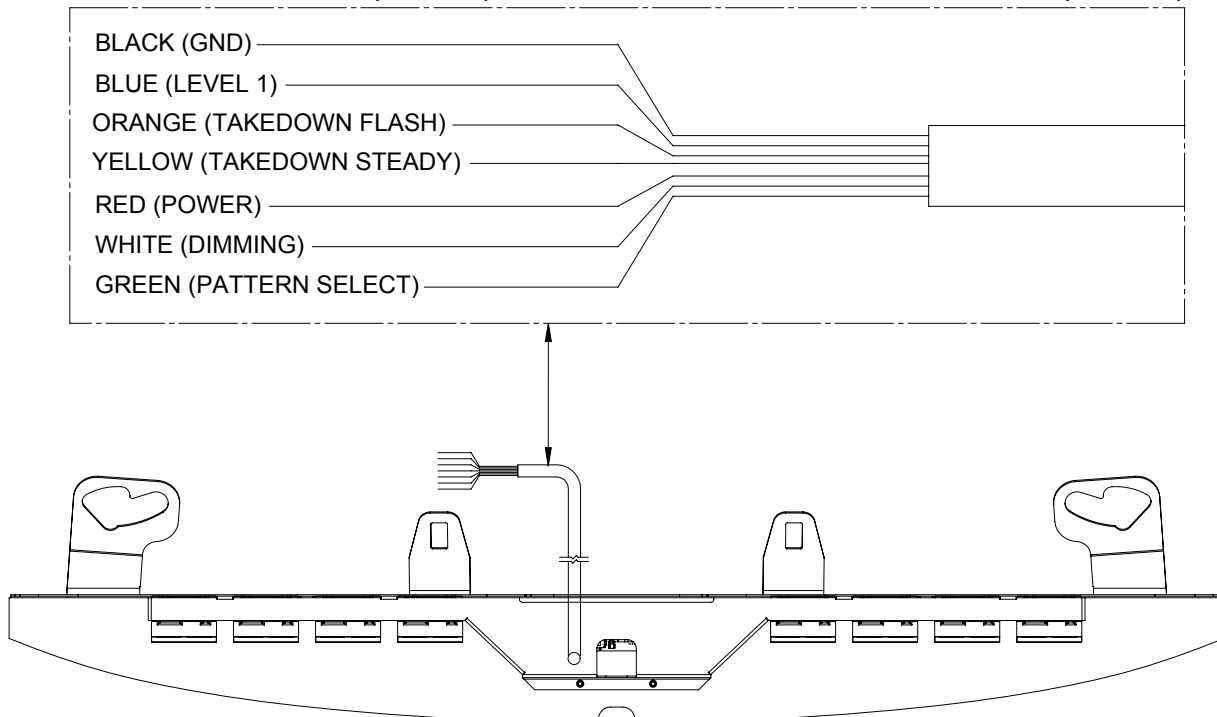

Steady Burn Option

The SuperVisor® can operate Light Head #2 (second Light Head from the driver side) in steady burn mode. To change the #2 Light Head from flashing to steady burn, remove the mounting screws that attach the SuperVisor's Cover to the Outer Panel to gain access to the printed circuit board inside (see the exploded view on page 8). Move the Shunt Option Jumper on the printed circuit board to the "OPTION JP1" position as shown below. The #2 Light Head should now operate in steady burn. Carefully replace the SuperVisor's Cover over the Outer Panel and replace the Cover Mounting Screws.

Note: Be extremely careful to replace the wiring such that you don't pinch a wire when you replace the SuperVisor's Cover. Test the unit to be sure that it works properly.

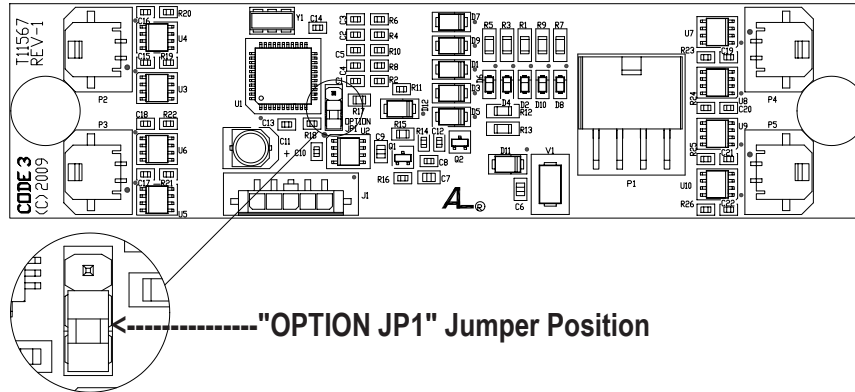

WARNING!  This Product contains high intensity TriCore® devices. To prevent eye damage, DO NOT stare into light beam at close range.

TriCore® Light Head Flash Pattern

To change the flash patterns of the TriCore Light Heads, activate the Light Bar in Level 1 and then momentarily touch the Green (Pattern Select) wire to +power. Repeating this procedure allows the operator to cycle through the numerous flash patterns offered until the desired pattern is achieved.

To reset the flash patterns to the factory default, activate the Light Bar in Level 1 and then hold the Green (Pattern Select) wire to +power for approximately 4 seconds.

TriCore Take Down Flash Pattern

Selecting Flash Patterns: The Take Down Lights can be programmed to flash at different rates.

STEP 1: Power-up the light bar. Select the Take Down Flash Mode (ORANGE) by applying +power. Programming will not work if more than one function is selected at a time.

STEP 2: Observe the flash pattern and determine which pattern is in operation (see Take Down Flash Patterns). This table shows the available flash patterns. Once the flash pattern has been determined, proceed to Step 3. **NOTE: The default flash pattern for Take Down Lights is Medium Single 115FPM.**

STEP 3: Scroll to the next pattern by momentarily holding the GREEN wire to +power for ~one (1) second. The light bar will stop flashing when the wire is connected to +power. Release the wire and the next pattern as listed in Table 5 will begin to flash. The new pattern is automatically stored each time.

Flash Patterns

STANDARD LIGHT HEAD FLASH PATTERNS		TAKE DOWN FLASH PATTERNS	
PATTERN NO	PATTERN DESCRIPTION	PATTERN NUMBER	PATTERN DESCRIPTION
1	FAST ALTERNATING QUAD FLASH 100ms/25ms	1	FAST QUAD 80FPM
2	PICKET FENCE SINGLE FLASH 200ms/25ms	2	SLOW QUAD 60FPM
3	ALTERNATING SINGLE FLASH 200ms/25ms	3	FAST SINGLE 375FPM
4	PICKET FENCE QUAD FLASH 100ms/25ms	4	FACTORY DEFAULT MEDIUM SINGLE 115FPM
5	PICKET FENCE SIX FLASH 75ms/25ms	5	SLOW SINGLE 60FPM
6	SLOW ALTERNATING QUAD FLASH 150ms/50ms	6	FAST DOUBLE 115FPM
7	SLOW ALTERNATING SIX FLASH 125ms/25ms	7	SLOW DOUBLE 60FPM
8	FAST ALTERNATING SIX FLASH 75ms/25ms	8	FAST SIX 80FPM
9	VARIABLE RATE PICKET FENCE, SINGLE FLASH	9	SLOW SIX 60FPM
10	ALTERNATING QUAD FLASH, 80 FPM, NFPA COMPLIANT	10	VARIABLE RATE SINGLE
11	CYCLE FLASH	11	NFPA QUAD 75FPM
12	SIMULTANEOUS QUAD FLASH, 75 FPM, NFPA COMPLIANT	12	CYCLE FLASH

Troubleshooting

All SuperVisors® are thoroughly tested prior to shipment. However, should you encounter a problem during installation or during the life of the product, follow the guide below for information on repair and troubleshooting. Additional information may be obtained from the factory technical help line at 314-996-2800.

Follow the guide below for information on repair and troubleshooting.

TROUBLESHOOTING GUIDE

Note: TriCore® modules must be replaced as a module. There are no user serviceable parts.

PROBLEM	QUESTIONS	POSSIBLE CAUSE	SOLUTION
TriCore® module not operating when powered.	N/A	a. Bad power/ground connection. b. Defective module.	a. Fix connection. b. Replace module

WARNING!



Any Disassembly of any of the TriCore Modules will result in loss of warranty coverage on the equipment.

Parts List

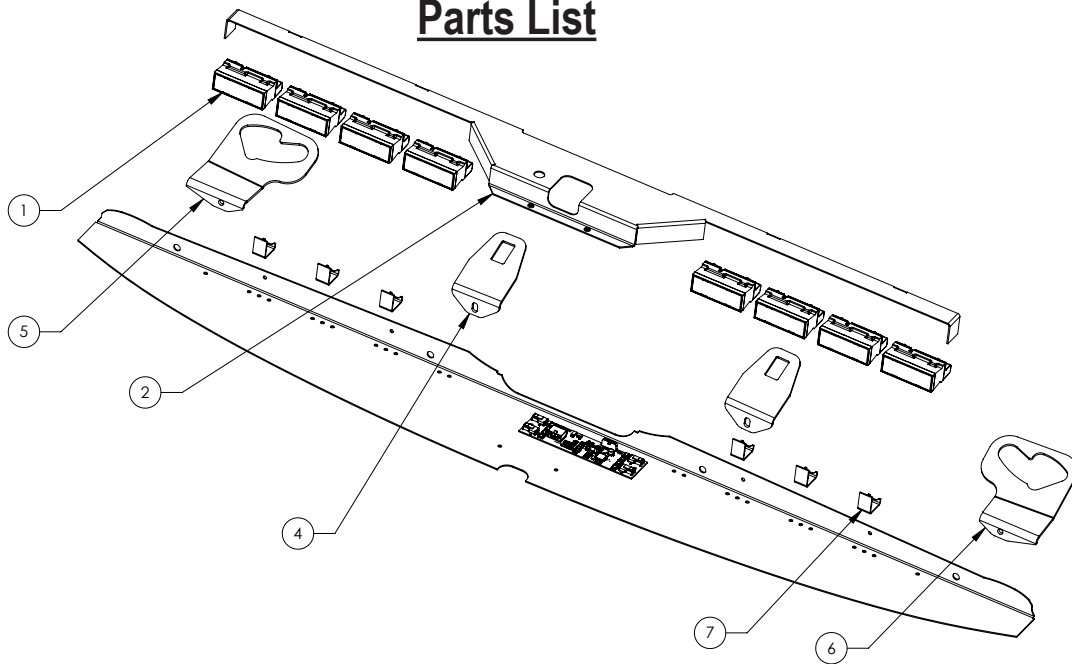

Reference Number	Part Description	Part Number
1	Tri-Core® Module	*Contact Code 3, Inc for P/N
2	Chassis	T56358
3	Outer Panel	T56357
4	Inner Mtg. Brkt. Tahoe	T14719
5	Outer Mtg. Brkt. Tahoe Pass Side	T14718
6	Outer Mtg. Brkt. Tahoe Drivr Side	T14717
7	Blank Bracket	T15056

Notes

Notes

Notes

WARRANTY

This product with TriCore® Technology was tested and found to be operational at the time of manufacture. Provided this product is installed and operated in accordance with the manufacturer's recommendations, Code 3®, Inc. warrants all parts and components (with the exception of all incandescent and halogen bulbs) of the product to be free of defects in material and workmanship for a period of one (1) year and TriCore light heads for a period of five (5) years from the date of purchase. This Warranty excludes normal wear & tear. Units demonstrated to be defective within the warranty period will be repaired or replaced at the factory service center at no cost. Code 3, Inc. will return the repaired product with transportation cost prepaid. Code 3, Inc. assumes no liability for expenses incurred in the packaging, handling, and shipping of the product to the Factory Technical Service Department for repair. For in-warranty product return authorization, questions regarding product warranty coverage or questions regarding out-of-warranty repair quotes, contact the Factory Technical Service Department.

The TriCore light heads are sealed as part of the quality control process. This Warranty is void if, in the judgment of Code 3, Inc. (1) an attempt has been made to break the light head seal or repair the light head, and/or (2) the product has been used with inappropriate or inadequate wiring or circuit protection, and/or (3) the product has failed as a result of abuse or unusual use and/or accidents.

CODE 3, INC. SHALL IN NO WAY BE LIABLE FOR ANY OTHER DAMAGES RELATING TO THE PRODUCT INCLUDING BUT NOT LIMITED TO CONSEQUENTIAL, INCIDENTAL, INDIRECT OR SPECIAL DAMAGES OR LOST PROFITS OR REVENUE; NOR ANY EXPENSES INCURRED IN THE REMOVAL AND/OR RE-INSTALLATION OF PRODUCTS REQUIRING SERVICE AND/OR REPAIR.

EXCEPT AS SET FORTH ABOVE, CODE 3, INC. MAKES NO OTHER EXPRESS OR IMPLIED WARRANTIES WHATSOEVER, INCLUDING, WITHOUT LIMITATION, WARRANTIES OF FITNESS FOR A PARTICULAR PURPOSE OR MERCHANTABILITY, WITH RESPECT TO THIS PRODUCT.

NEED HELP? Call our Technical Assistance HOT LINE - (314) 996-2800

PRODUCT RETURNS

If a product must be returned for repair or replacement*, please contact our factory to obtain a Return Goods Authorization Number (RGA number) before you ship the product to Code 3, Inc. Write the RGA number clearly on the package near the mailing label. Be sure you use sufficient packing materials to avoid damage to the product being returned while in transit.

*Code 3, Inc. reserves the right to repair or replace at its discretion. Code 3, Inc. assumes no responsibility or liability for expenses incurred for the removal and/or reinstallation of products requiring service and/or repair; nor for the packaging, handling, and shipping; nor for the handling of products returned to sender after the service has been rendered.

A PUBLIC SAFETY EQUIPMENT COMPANY

Code 3®, Inc.
10986 N. Warson Road
St. Louis, Missouri 63114-2029—USA
Ph. (314) 426-2700 Fax (314) 426-1337
www.code3pse.com