

# INSTALLATION & OPERATION MANUAL

WingMan™



**CODE 3**<sup>®</sup>  
A PUBLIC SAFETY EQUIPMENT COMPANY

## WingMan™

Interior Lighting System  
FORD CROWN VICTORIA  
UPPER REAR DECK LIGHT BAR

### CONTENTS:

Introduction .....	2
Unpacking & Pre-Installation .....	2
Installation & Mounting .....	3-5
Wiring Diagram & Instructions .....	6-7
LED Flash Pattern Selection & Troubleshooting .....	8-9
Narrowstik Wiring Diagram .....	10
Exploded View & Parts List .....	11
Notes .....	11
Warranty .....	12

For future reference record your product's serial no. here \_\_\_\_\_

**IMPORTANT:**

*Read all instructions and warnings before installing and using.*  
**INSTALLER:** *This manual must be delivered to the end user of this equipment.*

# Introduction

The Crown Vic Upper WingMan™ is an interior LED lighting system that fits in the rear deck area behind the rear seat in the upper portion of the rear window. It delivers a slim powerful warning signal to the rear of the vehicle without obstructing the driver's rear vision.

The WingMan is designed on a modular basis, which means that the light bar can be customized to meet most any requirements. The WingMan has room for up to eight LED lightheads. Each lighthead is individually wired for any flash pattern or combination of flash patterns required.



## WARNING!

The use of this or any warning device does not ensure that all drivers can or will observe or react to an emergency warning signal. Never take the right-of-way for granted. It is your responsibility to be sure you can proceed safely before entering an intersection, driving against traffic, responding at a high rate of speed, or walking on or around traffic lanes.

The effectiveness of this warning device is highly dependent upon correct mounting and wiring. Read and follow the manufacturer's instructions before installing or using this device. The vehicle operator should insure daily that all features of the device operate correctly. In use, the vehicle operator should insure the projection of the warning signal is not blocked by vehicle components (i.e.: open trunks or compartment doors), people, vehicles, or other obstructions.

This equipment is intended for use by authorized personnel only. It is the user's responsibility to understand and obey all laws regarding emergency warning devices. The user should check all applicable city, state and federal laws and regulations.

Code 3, Inc., assumes no liability for any loss resulting from the use of this warning device.

Proper installation is vital to the performance of this warning device and the safe operation of the emergency vehicle. It is important to recognize that the operator of the emergency vehicle is under psychological and physiological stress caused by the emergency situation. The warning device should be installed in such a manner as to: A) Not reduce the output performance of the system, B) Place the controls within convenient reach of the operator so that he can operate the system without losing eye contact with the roadway.

Emergency warning devices often require high electrical voltages and/or currents. Properly protect and use caution around live electrical connections. Grounding or shorting of electrical connections can cause high current arcing, which can cause personal injury and/or severe vehicle damage, including fire.

**PROPER INSTALLATION COMBINED WITH OPERATOR TRAINING IN THE PROPER USE OF EMERGENCY WARNING DEVICES IS ESSENTIAL TO INSURE THE SAFETY OF EMERGENCY PERSONNEL AND THE PUBLIC.**

## Unpacking & Pre-installation

Carefully remove the WingMan™ and place it on a flat surface, taking care not to scratch the lenses or damage the cable coming out of the end. Examine the unit for transit damage, etc. Report any damage to the carrier and keep the shipping carton.

Standard light bars are built to operate on 12 volt D.C. negative ground (earth) vehicles. If you have an electrical system other than 12 volt D.C. negative ground (earth), and have not ordered a specially wired light bar, contact the factory for instructions.

Test the unit before installation. To test, touch the black wire to the ground (earth) and the other wires to +12 volts D.C., in accordance with the instructions attached to the cable (an automotive battery is preferable for this test). Some units may be factory wired for control by a LED flasher or an ArrowStik Controller in which case the cable's wire tag should be consulted. A battery charger may be used, but please note that some electronic options (flashers, stingrays, etc.) may not operate normally when powered by a battery charger. If problems occur at this point, contact the factory.



## WARNING!

Utilizing non-factory supplied screws and/or mounting brackets and/or the improper number of screws may result in loss of warranty coverage on the equipment.

**Mounting Hardware** - All mounting hardware is packed in a bag inside the main carton. There are two brackets used to mount the WingMan™ to the vehicle. These are discussed in detail later.

## Installation Instructions-

**Step 1** Remove the two plastic Headliner retention plugs in the center rear part of the headliner by prying out with a wide flat bladed screwdriver (see figure 1).

**Step 1** Cut out the paper template sheets, align the two halves of the template and tape the template together (see figure 1)



FIGURE 1

**Step 2** Insert the two 3/8-16 x 1"lg sheet metal screws into the Upper WingMan mounting brackets (see figure 2)



FIGURE 2

**Step 3** Position the mounting brackets and thread the self tapping screws into the existing holes in the Crown Vic's sheet metal (see figure 3). Tighten the screws until the bracket crushes into the headliner material slightly (about as deep as the thickness of the brackets) but not so tight that the brackets can't be adjusted to line up with the mounting holes in the WingMan's outer panel.



**FIGURE 3**

**Step 4** Position the Upper WingMan behind the mounting brackets and thread the two 1/4" -20 x 1/2" lg philips head screws and internal tooth lock washers into the mounting holes in the outer panel of the WingMan (see figure 4).



**FIGURE 4**

**Step 5** Push up on the Upper WingMan to get it up against the headliner and tighten the mounting screws with a phillips screwdriver (see figure 5). The cable can then be routed as desired.



FIGURE 5

The bracket fasteners shown in figure 5 should not also be used as mounting points for radar guns, video cameras, etc. Only the WingMan lightbar should be mounted with the brackets.

**Caution:**Drilling into the housing of the light bar could damage wiring or other internal components.

# Wiring Diagram

BLACK = NEGATIVE GROUND  
 YELLOW = NOT USED  
 GREEN/WHT = NOT USED  
 PINK = NOT USED  
 RED = NOT USED  
 RED/WHT = NOT USED

FUZE SIZE CALCULATION  
 USE 1.5 AMP FOR EACH LED HEAD

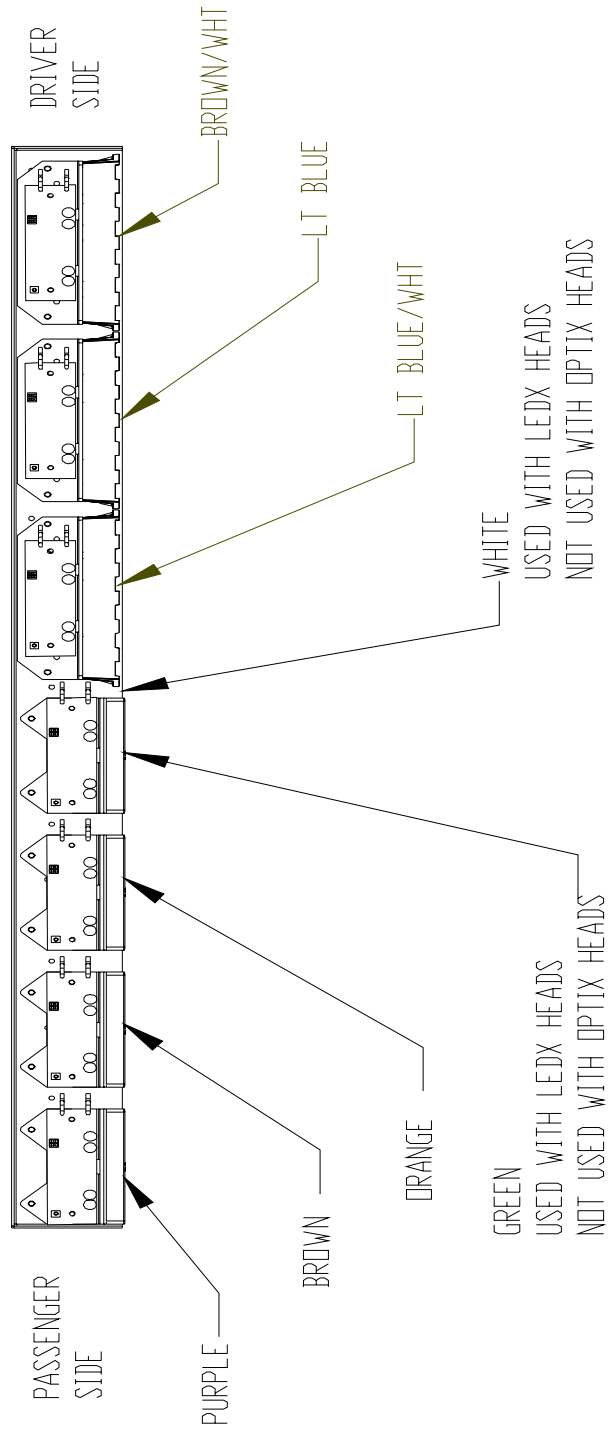

# Wiring Instructions

It is advisable to leave an extra loop of cable when installing the light bar to allow for future changes or reinstallations. Connect the black lead to a solid frame ground (earth), preferably, the (-) or ground (earth) side of the battery, and the remaining power wires to the +12V terminal of the battery, power switches, siren or RLS controller. Each light head is wired independently to allow complete flexibility of control.



## WARNING!

Larger wires and tight connections will provide longer service life for components. For high current wires it is highly recommended that terminal blocks or soldered connections be used with shrink tubing to protect the connections. Do not use insulation displacement connectors (e.g. 3M<sup>®</sup> Scotchlock type connectors). Route wiring using grommets and sealant when passing through compartment walls. Minimize the number of splices to reduce voltage drop. High ambient temperatures (e.g. underhood) will significantly reduce the current carrying capacity of wires, fuses, and circuit breakers. Use "SXL" type wire in engine compartment. All wiring should conform to the minimum wire size and other recommendations of the manufacturer and be protected from moving parts and hot surfaces. Looms, grommets, cable ties, and similar installation hardware should be used to anchor and protect all wiring. Fuses or circuit breakers should be located as close to the power takeoff points as possible and properly sized to protect the wiring and devices. Particular attention should be paid to the location and method of making electrical connections and splices to protect these points from corrosion and loss of conductivity. Ground terminations should only be made to substantial chassis components, preferably directly to the vehicle battery. The user should install a fuse sized to approximately 125% of the maximum Amp capacity in the supply line to protect against short circuits. For example, a 30 Amp fuse should carry a maximum of 24 Amps. **DO NOT USE 1/4" DIAMETER GLASS FUSES AS THEY ARE NOT SUITABLE FOR CONTINUOUS DUTY IN SIZES ABOVE 15 AMPS.** Circuit breakers are very sensitive to high temperatures and will "false trip" when mounted in hot environments or operated close to their capacity.

## LED MODULES

### Operating Specifications for directional module:

Operating Voltage: 10-16 VDC, Reverse Polarity Protection

Current Draw : Flashing Module

Red/Amber - .25A avg @ 12.8 Volts

Blue/White - .4A avg @ 12.8 Volts

Steady Burn Module

Red/Amber - .5A avg @ 12.8 Volts

Blue/White - .8A avg @ 12.8 Volts

Available Colors - Red , Blue, Amber, and White

# LED Light Head Flash Pattern

Place the unit on a clean work surface and remove the outer cover. With the chassis facing up, locate each lighthouse module circuit board. To change the flash patterns of the LED Light Heads, touch both posts of the J1 header simultaneously with an electrically conductive tool such as a screw driver blade (see figure 6 below). Repeating this procedure allows the operator to cycle through the numerous flash patterns offered until the desired pattern is achieved.

Directional module Flash Pattern - Table 2

- |                      |                    |
|----------------------|--------------------|
| CycleFlash (DEFAULT) | Quad Pop Flash75   |
| NFPA QuadFlash75     | Triple Pop Flash75 |
| Steadyburn           | SingleFlash375     |
| ModelFlash           | SingleFlash250     |
| ActiveFlash          | SingleFlash150     |
| FiveFlash70          | FiveFlash150       |
| QuadFlash70          | QuadFlash150       |
| TripleFlash70        | DoubleFlash150     |
| DoubleFlash70        | TripleFlash150     |
| SingleFlash75        |                    |

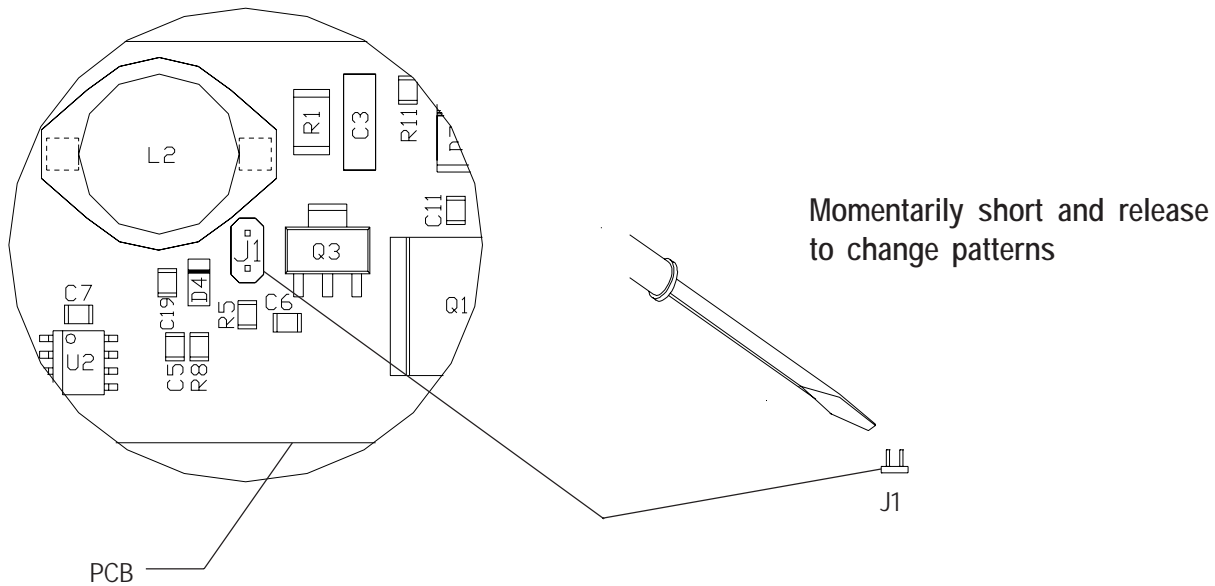

Flash Pattern Header for OPTIX/LEDX

## LED Fusing Considerations

Although the average current draw per module is very low, due to the type of circuit used to power each module, the instantaneous peak current to a module can be significantly higher during low voltage conditions. To avoid prematurely blowing ATO style fuses or tripping breakers it is recommended the following rule-of-thumb be used to size fuses or breakers. This is especially important in light bars with many LED modules running off a single fused source,

### Minimum fuse size calculation:

#### For LED 12 volt electrical current

1.5 x (number of modules being fused)

Example: 2 intersection modules and 6 directional modules.

Minimum fuse requirement for single fuse -  $1.5 (8) = 12 A$

## Product Features

LED lighthouse options: Red, Blue, Amber; Directional or Spreading; Flashing or Steady Burn Control

LED lighthouse types: LED-X, Optix, LCLED

Size: 36.75" long x 2.00" tall x 7.12" deep

Weight: 7.5 lb

## NarrowStik Version

The WingMan can be factory configured as a traffic director and operated using an NarrowStik Control Head. Please refer to the NarrowStik Control Head Manual packaged with the control head for installation, wiring connections, and operation of the Control Head.

## Wiring

Refer to the Narrowstik wiring on page 10 for wire designations. For models with independently flashing red/blue heads located on each end, the Blue and Brown wires will be used to control these heads. The Blue wire is connected to +12V and the Brown to Ground. Refer to the Control Head manual for operation with the Control Head.

**WARNING!**



This Product contains high intensity LED devices. To prevent eye damage, DO NOT stare into light beam at close range.

## Troubleshooting

All WingMan Rear Bars are thoroughly tested prior to shipment. However, should you encounter a problem during installation or during the life of the product, follow the guide below for information on repair and troubleshooting. Additional information may be obtained from the factory technical help line at 314-426-2700 ext. 2131.

### TROUBLESHOOTING GUIDE

**Note:** LED modules must be replaced as a module. There are no user serviceable parts.

PROBLEM	QUESTIONS	POSSIBLE CAUSE	SOLUTION
LED module not operating when powered.	N/A	a. Bad power/ground connection. b. Defective module.	a. Fix connection. b. Replace module

RED = POWER, +12VDC  
 RED/WHT = POWER, +12VDC  
 WHITE WIRE = DIM MODE

LEDX Version

DRIVERS  
SIDE

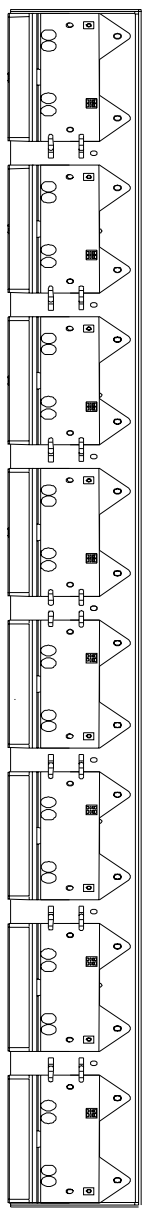

PASSENGERS  
SIDE

BLUE    YELLOW    GREY    GREEN    VIOLET    TAN    DRANGE    BROWN

Optix Version

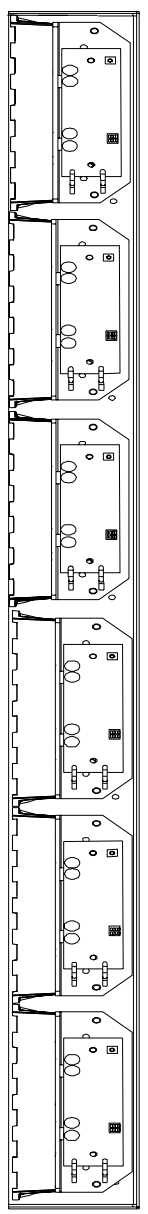

YELLOW    GREY    GREEN    VIOLET    TAN    DRANGE

Narrowstik Wire Designations

# Parts List

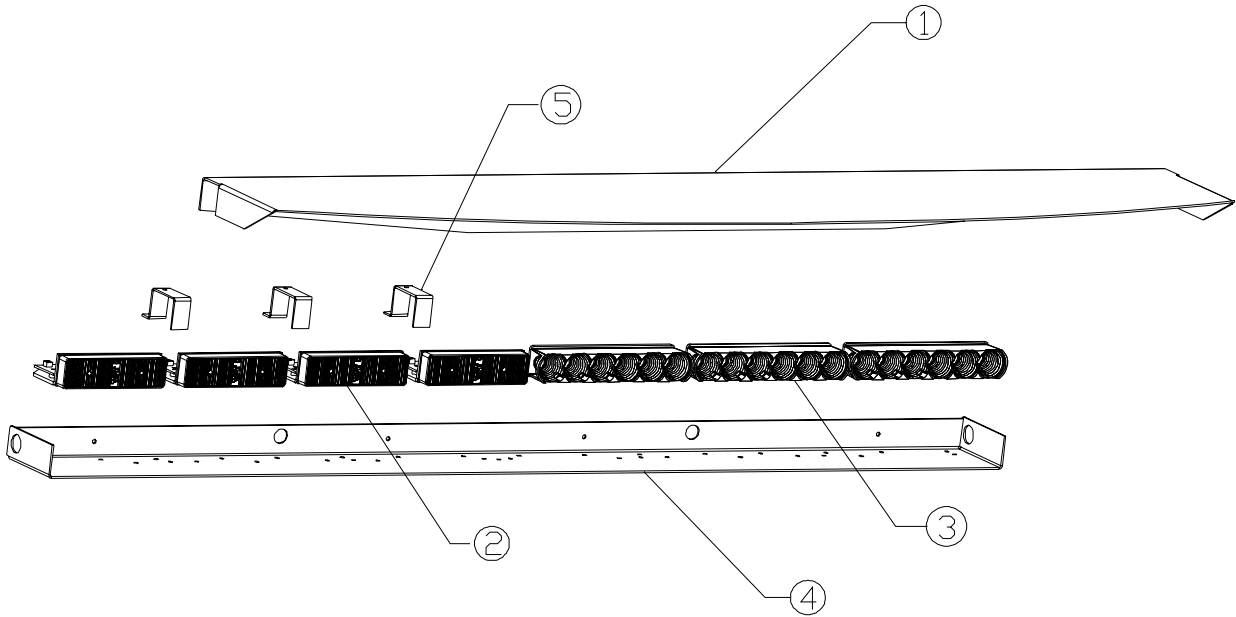

<u>Reference Number</u>	<u>Part Description</u>	<u>Part Number</u>
1	Outer Panel	T09674
2	*LED Module	*Contact Code 3, Inc for P/N
3	*OPTIX Module	*Contact Code 3, Inc for P/N
4	Chassis	T09673
5	Outer Panel Filler Brkt Small LEDX	T09676
6	Mounting Brkt. Not Shown	T09675

## NOTES:

# WARRANTY

Code 3, Inc.'s emergency devices are tested and found to be operational at the time of manufacture. Provided they are installed and operated in accordance with manufacturer's recommendations, Code 3, Inc. guarantees all parts and components except the lamps to a period of 1 year, LED Lighthead modules to a period of 5 years (unless otherwise expressed) from the date of purchase or delivery, whichever is later. Units demonstrated to be defective within the warranty period will be repaired or replaced at the factory service center at no cost.

Use of lamp or other electrical load of a wattage higher than installed or recommended by the factory, or use of inappropriate or inadequate wiring or circuit protection causes this warranty to become void. Failure or destruction of the product resulting from abuse or unusual use and/or accidents is not covered by this warranty. Code 3, Inc. shall in no way be liable for other damages including consequential, indirect or special damages whether loss is due to negligence or breach of warranty.

**CODE 3, INC. MAKES NO OTHER EXPRESS OR IMPLIED WARRANTY INCLUDING, WITHOUT LIMITATION, WARRANTIES OF FITNESS OR MERCHANTABILITY, WITH RESPECT TO THIS PRODUCT.**

# PRODUCT RETURNS

If a product must be returned for repair or replacement\*, please contact our factory to obtain a Return Goods Authorization Number (RGA number) before you ship the product to Code 3, Inc. Write the RGA number clearly on the package near the mailing label. Be sure you use sufficient packing materials to avoid damage to the product being returned while in transit.

\*Code 3, Inc. reserves the right to repair or replace at its discretion. Code 3, Inc. assumes no responsibility or liability for expenses incurred for the removal and /or reinstallation of products requiring service and/or repair.; nor for the packaging, handling, and shipping; nor for the handling of products returned to sender after the service has been rendered.

Code 3<sup>®</sup>, Inc.  
10986 N. Warson Road  
St. Louis, Missouri 63114-2029—USA  
Ph. (314) 426-2700 Fax (314) 426-1337  
[www.code3pse.com](http://www.code3pse.com)