

INSTALLATION & OPERATION MANUAL

WingMan™

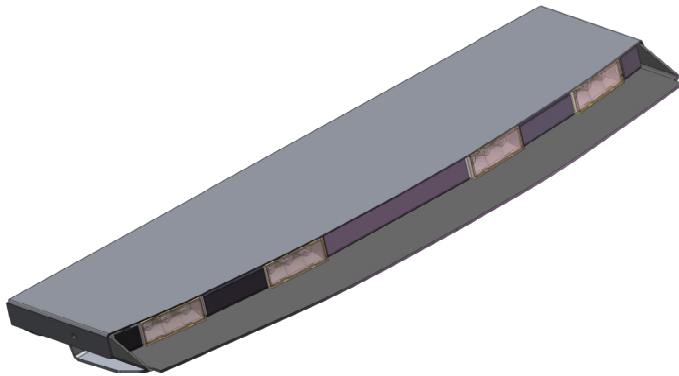

Short Version

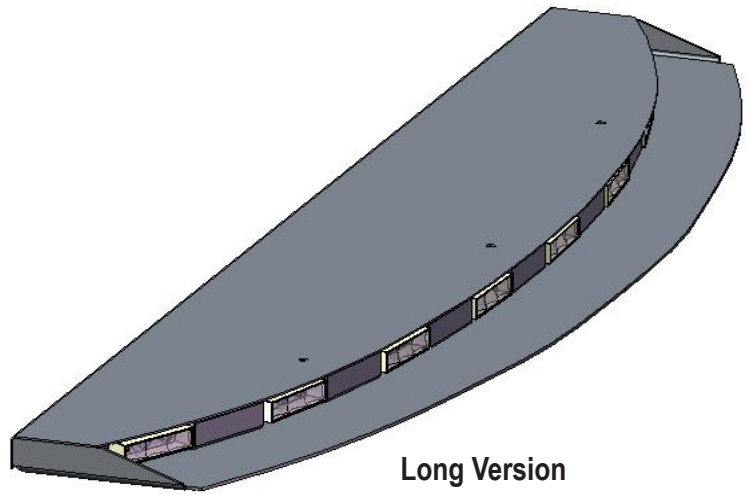

Long Version



WingMan™ with TriCore® Technology

U.S. Patent Nos. 7,153,015 and 7,300,175, Other Patents Pending

Interior Lighting System

DODGE CHARGER

REAR DECK LIGHT BAR

CONTENTS:

Introduction.....	2
Unpacking & Pre-Installation.....	2
Installation & Mounting.....	3-4
Wiring Diagram - Instructions.....	4-5
Flash Pattern Selection.....	6
Troubleshooting - Exploded View & Parts List.....	7
Warranty.....	8

For future reference record your product's serial no. here _____

IMPORTANT:

Read all instructions and warnings before installing and using.

INSTALLER:

This manual must be delivered to the end user of this equipment.

Introduction

The WingMan™ with TriCore® Technology is an interior lighting system that fits in the rear deck area behind the rear seat. The WingMan has room for up to eight TriCore light heads.

Product Features

TriCore light head options: Red, Blue, Amber, and White-----Flashing or Steady Burn Control
Size: 49.875" long x 2.00" tall x 7.25" deep-----Weight: 7.5 lbs

The use of this or any warning device does not ensure that all drivers can or will observe or react to an emergency warning signal. Never take the right-of-way for granted. It is your responsibility to be sure you can proceed safely before entering an intersection, driving against traffic, responding at a high rate of speed, or walking on or around traffic lanes. The effectiveness of this warning device is highly dependent upon correct mounting and wiring. Read and follow the manufacturer's instructions before installing or using this device. The vehicle operator should insure daily that all features of the device operate correctly. In use, the vehicle operator should insure the projection of the warning signal is not blocked by vehicle components (i.e.: open trunks or compartment doors), people, vehicles, or other obstructions. This equipment is intended for use by authorized personnel only. It is the user's responsibility to understand and obey all laws regarding emergency warning devices. The user should check all applicable city, state and federal laws and regulations. Code 3, Inc., assumes no liability for any loss resulting from the use of this warning device. Proper installation is vital to the performance of this warning device and the safe operation of the emergency vehicle. It is important to recognize that the operator of the emergency vehicle is under psychological and physiological stress caused by the emergency situation. The warning device should be installed in such a manner as to: A) Not reduce the output performance of the system, B) Place the controls within convenient reach of the operator so that he can operate the system without losing eye contact with the roadway. Emergency warning devices often require high electrical voltages and/or currents. Properly protect and use caution around live electrical connections. Grounding or shorting of electrical connections can cause high current arcing, which can cause personal injury and/or severe vehicle damage, including fire. Any electronic device may create or be affected by electromagnetic interference. After installation of any electronic device operate all equipment simultaneously to insure that operation is free of interference. Never power emergency warning equipment from the same circuit or share the same grounding circuit with radio communication equipment. All devices should be mounted in accordance with the manufacturer's instructions and securely fastened to vehicle elements of sufficient strength to withstand the forces applied to the device. Driver and/or passenger air bags (SRS) will affect the way equipment should be mounted. This device should be mounted by permanent installation and within the zones specified by the vehicle manufacturer, if any. Any device mounted in the deployment area of an air bag will damage or reduce the effectiveness of the air bag and may damage or dislodge the device. Installer must be sure that this device, its mounting hardware and electrical supply wiring does not interfere with the air bag or the SRS wiring or sensors. Mounting the unit inside the vehicle by a method other than permanent installation is not recommended as unit may become dislodged during swerving, sudden braking or collision. Failure to follow instructions can result in personal injury. **PROPER INSTALLATION COMBINED WITH OPERATOR TRAINING IN THE PROPER USE OF EMERGENCY WARNING DEVICES IS ESSENTIAL TO INSURE THE SAFETY OF EMERGENCY PERSONNEL AND THE PUBLIC.**



WARNING!

Unpacking & Pre-installation

Carefully remove the WingMan and place it on a flat surface, taking care not to scratch the lenses or damage the cable coming out of the top. Examine the unit for transit damage, broken lamps, etc. Report any damage to the carrier and keep the shipping carton.

Standard light bars are built to operate on 12 volt D.C. negative ground (earth) vehicles. If you have an electrical system other than 12 volt D.C. negative ground (earth), and have not ordered a specially wired light bar, contact the factory for instructions.

Test the unit before installation. To test, touch the black wire to the ground (earth) and the other wires to +12 volts D.C., in accordance with the instructions attached to the cable (an automotive battery is preferable for this test). A battery charger may be used, but note that some electronic options may not operate normally when powered by a battery charger. If problems occur at this point, contact the factory.

Note: Before beginning the installation process, be absolutely certain that the Light Bar functions as desired (See page 6 for options)!

WARNING!



Utilizing non-factory supplied screws and/or mounting brackets and/or the improper number of screws may result in loss of warranty coverage on the equipment.

Mounting Hardware - All mounting hardware is included. There are two brackets and two mounting plates used to mount the WingMan™ to the vehicle. These are discussed in detail later.

Installation Instructions

Step 1 Locate and remove the (6) Christmas Tree fasteners (see Figures 1 and 2) holding the fiber inner/upper trunk cover. Remove the fiber inner/upper trunk cover (see Figure 3).



FIGURE 1



FIGURE 2



FIGURE 3

Step 2 From inside and lying face up on the trunk floor, look up at the inner roof of the trunk, locate the holes (see the round and rectangular holes shown in Figure 4). With a steel scale centered and aligned with the holes, mark the center line as shown in Figure 5. When the center line is in the correct location it will look as shown in Figure 6.



FIGURE 4

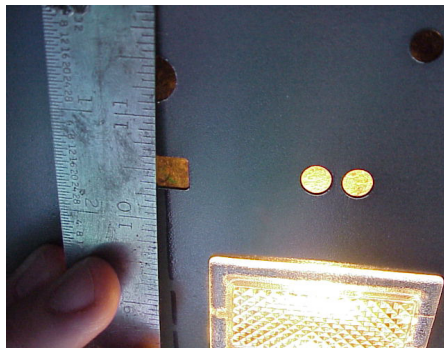

FIGURE 5



FIGURE 6

Step 3 Measure 12 inches over from the center line just marked in **Step 2 (Figure 6 above)** towards the passenger side, make a mark at the center of the bottom of the indented rectangular area, and drill a 3/8" diameter hole through the sheet metal and the rear deck fabric (as shown in Figure 7), then measure 12 inches over from the center line towards the driver side, make a mark in the center of the square indented area, and drill a 3/8" diameter hole through the sheet metal and the rear deck fabric (as shown in Figure 8). The result is two holes that are 24" apart and located in the approximate center of the two recessed areas of the rear deck sheet metal. **Note: Make sure any OEM wiring is out of the way so you don't damage the wiring when drilling the holes!**

Step 4 Enlarge the hole between the vehicle's existing rectangular punched hole and the small plastic fastener as shown in Figure 9 with a 3/8" diameter drill and drill through the rear deck fabric for the WingMan Power Cable. **Note: Again, make sure any OEM wiring is out of the way so you don't damage the wiring when drilling the holes!**



FIGURE 7



FIGURE 8



FIGURE 9

Installation Instructions-Cont.

Step 5 Insert (1) 1/4-20 X 1 3/4" long carriage bolt from the parts bag through the long slot in each of the (2) mounting brackets. Position the mounting brackets with the long slotted end towards the rear of the vehicle and with the stepped up area of the mounting bracket towards the front of the vehicle (as shown in Figure 10). Push the carriage bolts through the holes that you drilled in the rear deck in **Step 3** making sure the brackets are parallel to each other.

Step 6 From inside the trunk, slip a 1/4" fender washer, a 1/4" internal tooth lock washer, and thread a 1/4-20 hex nut from the parts bag onto each of the 1/4-20 X 1 3/4" long carriage bolts. Thread the nut as far up onto the carriage bolt as you can by hand and tighten the nuts as shown in Figure 11. **Note: Make sure to tighten the bolts until the mounting brackets crush fairly deep into the rear deck fabric and are tight. Also make sure the brackets stay parallel to each other as you tighten the nuts!**

Step 7 Feed the WingMan™ Power Cable through the hole you drilled in **Step 4** and into the trunk (see Figure 12).

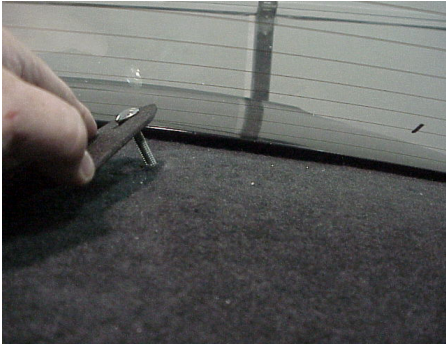

FIGURE 10



FIGURE 11



FIGURE 12

Step 8 Install the WingMan by tipping the rear of the bar down as you locate it in place towards the back of the car and into position over the mounting brackets. You will have to continue feeding the cable through the hole simultaneously while positioning the bar over the mounting brackets.

Step 9 Line up the slots in the outer panel mounting plates with the threaded holes in the mounting brackets and in the WingMan and thread the (4) supplied 1/4-20 x 1/2" bolts and internal tooth lock washers (see Figure 13). Tighten the 1/4-20 x 1/2" bolts with a phillips screwdriver (see Figure 14). **Note: You may have to rotate the two mounting brackets slightly to align them with the mounting plates, the holes in the mounting brackets, and the mounting holes in the WingMan.**

Step 10 Center the WingMan in the rear deck area and push it firmly back against the rear window so that the gasket makes contact with the glass. **Note: You may have to slightly loosen the 1/4-20 hex mounting nuts in the trunk to allow the WingMan to move back into position.**

Note: If the Gasket has wavy areas where it contacts the rear window you can press down firmly all along the rear contour on top of the WingMan as far back as you can reach to allow the gasket to pop back into shape.



FIGURE 13



FIGURE 14

The bracket fasteners shown in Figures 13 and 14 make excellent hard mounting points for radar guns, video cameras, etc. **Caution: Drilling into the housing of the light bar could damage wiring or other internal components.**

Wiring Instructions

It is advisable to leave an extra loop of cable when installing the light bar to allow for future changes or reinstallations. Connect the black lead to a solid frame ground (earth), preferably the (-) or ground (earth) side of the battery, and the power wire to the +12V terminal of the battery. Connect the remaining wires as shown on page 5.



Larger wires and tight connections will provide longer service life for components. For high current wires it is highly recommended that terminal blocks or soldered connections be used with shrink tubing to protect the connections. Do not use insulation displacement connectors (e.g. 3M® Scotchlock type connectors). Route wiring using grommets and sealant when passing through compartment walls. Minimize the number of splices to reduce voltage drop. High ambient temperatures (e.g. under hood) will significantly reduce the current carrying capacity of wires, fuses, and circuit breakers. Use "SXL" type wire in engine compartment. All wiring should conform to the minimum wire size and other recommendations of the manufacturer and be protected from moving parts and hot surfaces. Looms, grommets, cable ties, and similar installation hardware should be used to anchor and protect all wiring. Fuses or circuit breakers should be located as close to the power takeoff points as possible and properly sized to protect the wiring and devices. Particular attention should be paid to the location and method of making electrical connections and splices to protect these points from corrosion and loss of conductivity. Ground terminations should only be made to substantial chassis components, preferably directly to the vehicle battery. The user should install a fuse sized to approximately 125% of the maximum Amp capacity in the supply line to protect against short circuits. For example, a 30 Amp fuse should carry a maximum of 24 Amps. **DO NOT USE 1/4" DIAMETER GLASS FUSES AS THEY ARE NOT SUITABLE FOR CONTINUOUS DUTY IN SIZES ABOVE 15 AMPS.** Circuit breakers are very sensitive to high temperatures and will "false trip" when mounted in hot environments or operated close to their capacity.

Wiring Diagram - STANDARD

FUSE WITH CUSTOMER SUPPLIED 10 AMP FUSE

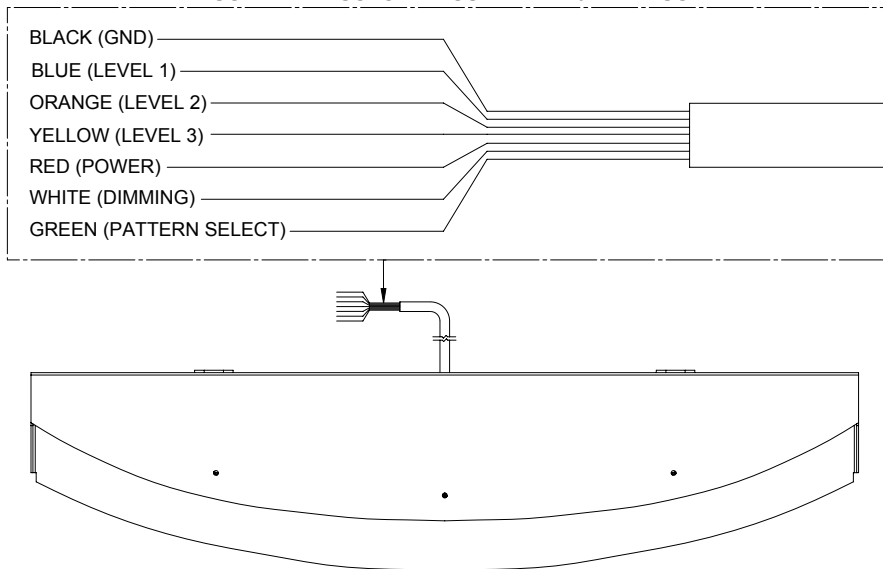

Wiring Diagram - WITH ARROWSTIK®

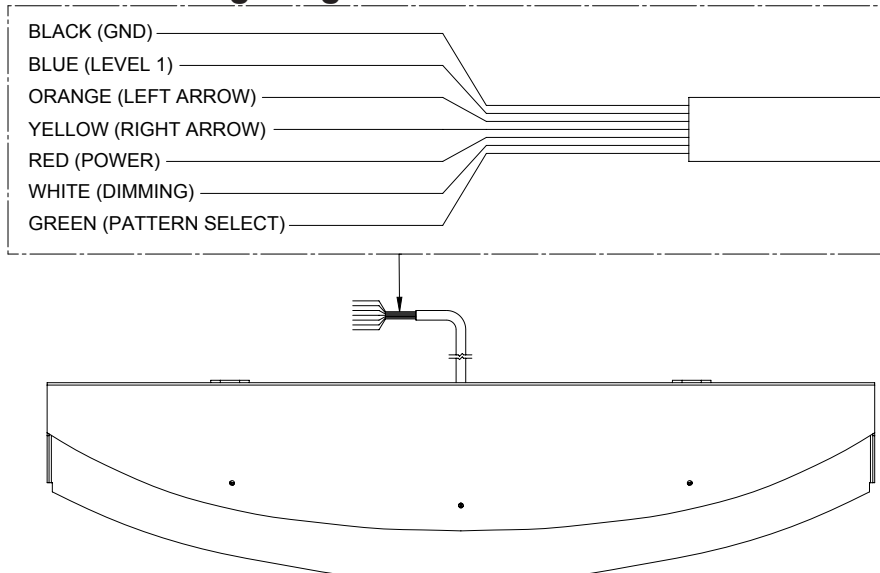

6 HEAD ARROWSTIK® W (2) OUTER LIGHT HDS FLASHING ALTERNATELY

The WingMan™ can be configured as a 6 or 8 head ArrowStik. To change the WingMan from an 8 head ArrowStik to a 6 Light Head configuration with the (2) Outboard Light Heads flashing alternately, remove the mounting screws that attach the WingMan's Cover to the Outer Panel to gain access to the printed circuit board inside (see the exploded view on page 7). Move the Shunt Option Jumper (JP1) on the printed circuit board to the "OPTION JP1" position as shown below. When configured for a 6 head operation the (2) Outboard Light Heads will alternate during any ArrowStik mode. Carefully replace the WingMan's Cover over the Outer Panel and replace the Cover Mounting Screws.

Note: Be extremely careful to replace the wiring such that you don't pinch a wire when you replace the WingMan's Cover. Test the unit to be sure that it works properly.

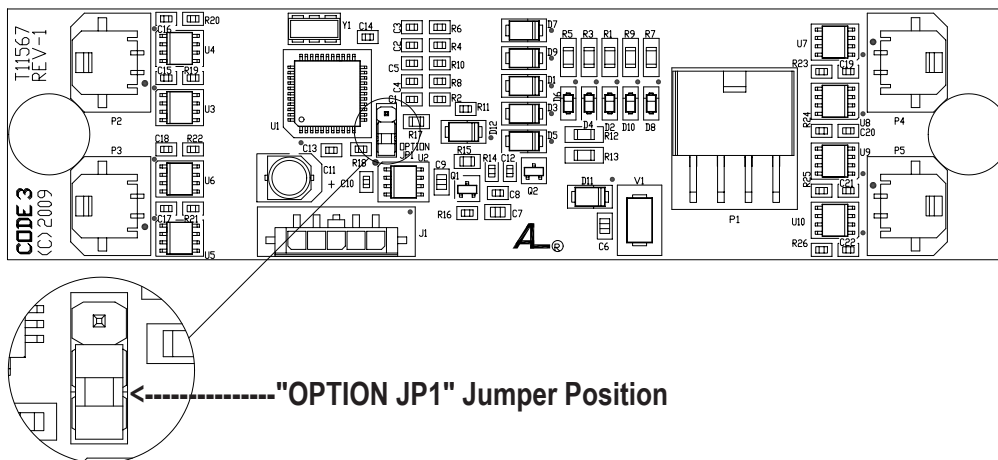

Flash Pattern Changes

WARNING!



This Product contains high intensity TriCore® devices. To prevent eye damage, DO NOT stare into light beam at close range.

TriCore® Light Head Flash Pattern

To change the flash patterns of the TriCore® Light Heads for either Standard or ArrowStik® patterns, activate the Light Bar in Level 1 or any ArrowStik mode and then momentarily touch the Green (Pattern Select) wire to +power. Repeating this procedure allows the operator to cycle through the numerous flash patterns offered until the desired pattern is achieved. Repeat for all modes as needed.

Note: Each ArrowStik mode must be set individually.

To reset the flash patterns to the factory default, activate the Light Bar in Level 1 or any ArrowStik mode and then hold the Green (Pattern Select) wire to +power for approximately 4 seconds.

- Note:**
- 1-Resetting the Standard patterns will reset only the Level 1 flash patterns
 - 2-Resetting the ArrowStik patterns in any ArrowStik mode will reset all ArrowStik flash patterns.

Flash Patterns

STANDARD LIGHT HEAD FLASH PATTERNS		ARROWSTIK FLASH PATTERNS	
PATTERN NO	PATTERN DESCRIPTION	PATTERN NUMBER	PATTERN DESCRIPTION
1	FAST ALTERNATING QUAD FLASH 100ms/25ms	1	Building, Fast Speed
2	PICKET FENCE SINGLE FLASH 200ms/25ms	2	Building, Medium Speed
3	ALTERNATING SINGLE FLASH 200ms/25ms	3	Building, Slow Speed
4	PICKET FENCE QUAD FLASH 100ms/25ms	4	Building, 3 Flash, Fast Speed
5	PICKET FENCE SIX FLASH 75ms/25ms	5	Building, 3 Flash, Medium Speed
6	SLOW ALTERNATING QUAD FLASH 150ms/50ms	6	Building, 3 Flash, Slow Speed
7	SLOW ALTERNATING SIX FLASH 125ms/25ms	7	Traveling Ball, 3 Flash, Fast Speed
8	FAST ALTERNATING SIX FLASH 75ms/25ms	8	Traveling Ball, 3 Flash, Medium Speed
9	VARIABLE RATE PICKET FENCE, SINGLE FLASH	9	Traveling Ball, 3 Flash, Slow Speed
10	ALTERNATING QUAD FLASH, 80 FPM, NFPA COMPLIANT	10	Build/Collapse, Fast Speed
11	CYCLE FLASH	11	Build/Collapse, Medium Speed
12	SIMULTANEOUS QUAD FLASH, 75 FPM, NFPA COMPLIANT	12	Build/Collapse, Slow Speed

Troubleshooting

All WingMan™ Products are thoroughly tested prior to shipment. However, should you encounter a problem during installation or during the life of the product, follow the guide below for information on repair and troubleshooting. Additional information may be obtained from the factory technical help line at 314-996-2800.

Follow the guide below for information on repair and troubleshooting.

TROUBLESHOOTING GUIDE

Note: TriCore® Modules must be replaced as a module. There are no user serviceable parts.

PROBLEM	QUESTIONS	POSSIBLE CAUSE	SOLUTION
TriCore Module not operating when powered.	N/A	a. Bad power/ground connection. b. Defective module.	a. Fix connection. b. Replace module



Any disassembly of any of the TriCore light heads will result in loss of warranty coverage on the equipment.

Parts List

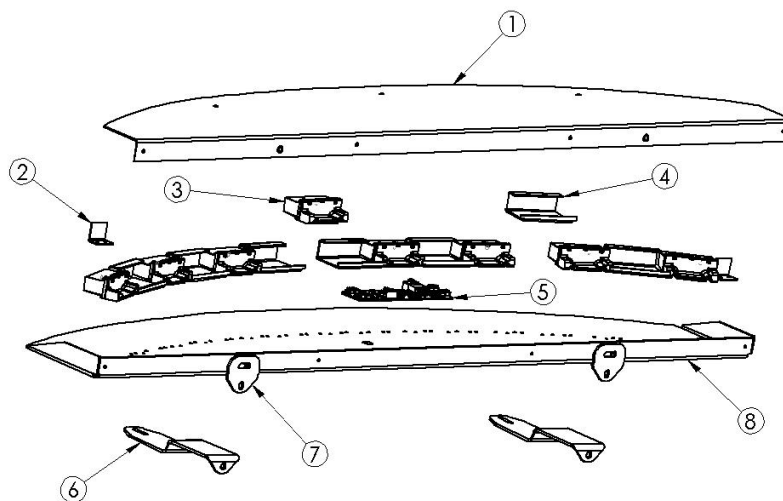

Reference Number	Part Description	Part Number
1	Outer Panel-Long	T13922
1	Outer Panel-Short-Not Shown	T15318
2	1" Blanking Bracket	T16254
3	TriCore® Module	*Contact Code 3, Inc for P/N
4	2.75" Blank Bracket	T56353
4	7" Blank Bracket-Center Short WingMan-Not Shown	T15319
5	Circuit Board Assembly	T11568
6	Mounting Brkt.- Standard Single Level	T13924
7	Mounting Plate	T09652
8	Chassis-Long	T16253
8	Chassis-Short-Not Shown	T15312

WARRANTY

This product with TriCore® Technology was tested and found to be operational at the time of manufacture. Provided this product is installed and operated in accordance with the manufacturer's recommendations, Code 3®, Inc. warrants all parts and components (with the exception of all incandescent and halogen bulbs) of the product to be free of defects in material and workmanship for a period of one (1) year and TriCore light heads for a period of five (5) years from the date of purchase. This Warranty excludes normal wear & tear. Units demonstrated to be defective within the warranty period will be repaired or replaced at the factory service center at no cost. Code 3, Inc. will return the repaired product with transportation cost prepaid. Code 3, Inc. assumes no liability for expenses incurred in the packaging, handling, and shipping of the product to the Factory Technical Service Department for repair. For in-warranty product return authorization, questions regarding product warranty coverage or questions regarding out-of-warranty repair quotes, contact the Factory Technical Service Department.

The TriCore light heads are sealed as part of the quality control process. This Warranty is void if, in the judgment of Code 3, Inc. (1) an attempt has been made to break the light head seal or repair the light head, and/or (2) the product has been used with inappropriate or inadequate wiring or circuit protection, and/or (3) the product has failed as a result of abuse or unusual use and/or accidents.

CODE 3, INC. SHALL IN NO WAY BE LIABLE FOR ANY OTHER DAMAGES RELATING TO THE PRODUCT INCLUDING BUT NOT LIMITED TO CONSEQUENTIAL, INCIDENTAL, INDIRECT OR SPECIAL DAMAGES OR LOST PROFITS OR REVENUE; NOR ANY EXPENSES INCURRED IN THE REMOVAL AND/OR RE-INSTALLATION OF PRODUCTS REQUIRING SERVICE AND/OR REPAIR.

EXCEPT AS SET FORTH ABOVE, CODE 3, INC. MAKES NO OTHER EXPRESS OR IMPLIED WARRANTIES WHATSOEVER, INCLUDING, WITHOUT LIMITATION, WARRANTIES OF FITNESS FOR A PARTICULAR PURPOSE OR MERCHANTABILITY, WITH RESPECT TO THIS PRODUCT.

NEED HELP? Call our Technical Assistance HOT LINE - (314) 996-2800

PRODUCT RETURNS

If a product must be returned for repair or replacement*, please contact our factory to obtain a Return Goods Authorization Number (RGA number) before you ship the product to Code 3, Inc. Write the RGA number clearly on the package near the mailing label. Be sure you use sufficient packing materials to avoid damage to the product being returned while in transit.

*Code 3, Inc. reserves the right to repair or replace at its discretion. Code 3, Inc. assumes no responsibility or liability for expenses incurred for the removal and/or reinstallation of products requiring service and/or repair.; nor for the packaging, handling, and shipping; nor for the handling of products returned to sender after the service has been rendered.

CODE 3[®]
A PUBLIC SAFETY EQUIPMENT COMPANY

Code 3®, Inc.
10986 N. Warson Road
St. Louis, Missouri 63114-2029—USA
Ph. (314) 426-2700 Fax (314) 426-1337
www.code3pse.com