

INSTALLATION SHEET FOR XP9501

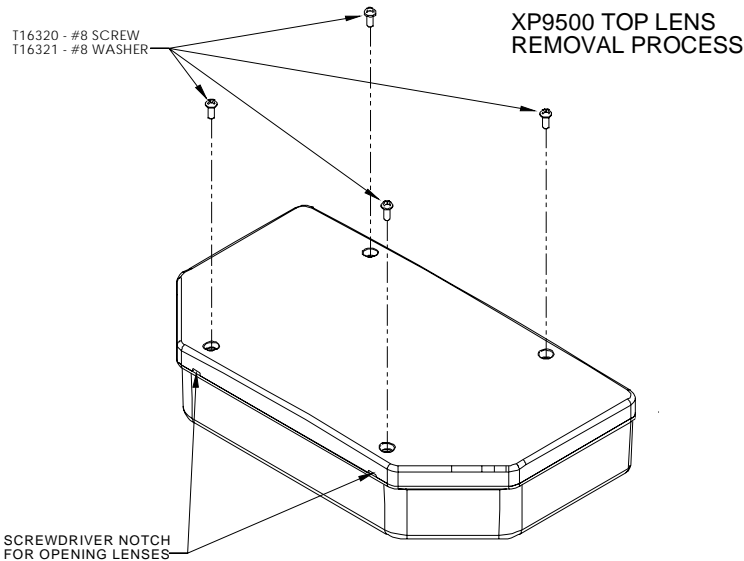

The XP9501 is shipped with the mounting foot attached to keep the assembly stable during shipment and to eliminate shipping damage. Remove the lens cover as shown below. Set fasteners aside.



Parts List/Data

T51001	Lower Lens
T51011	Upper Lens
S24194	Mounting Foot

call factory for lighthead information

Dimensions

Beacon only: 12.5"W x 7"D x 2.7"H
Beacon w/ foot: 12.5"W x 7"D x 3.9"H

Next, remove the five screws attaching the beacon to the mounting foot. Set these fasteners aside. Separate the beacon from the mounting foot.

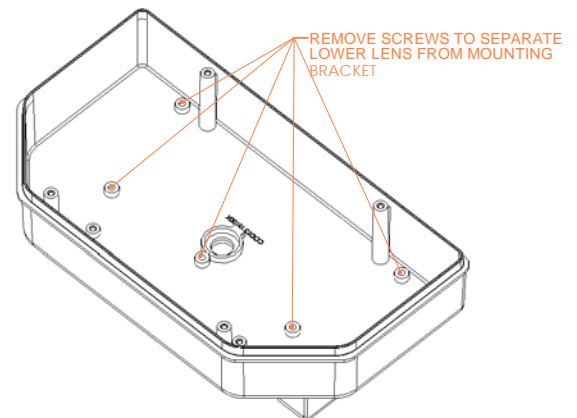

Place the mounting foot where it is to be assembled to the vehicle and mark the locations. The holes are large enough for 1/4" fasteners (not included). After the mounting foot is installed, route the cable through the hole in the foot and reassemble the beacon to the foot. Assemble the lens cover to the top to complete the assembly.

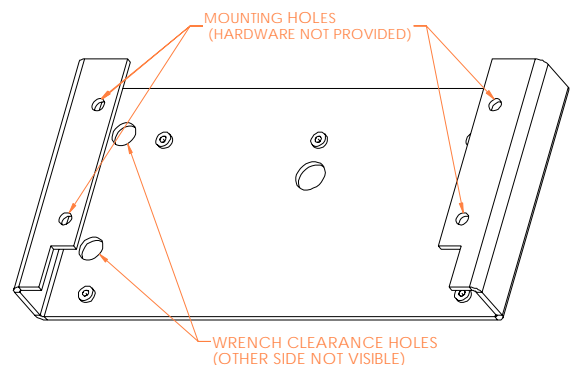

LED MODULES

Flash patterns can be changed by shorting the 2-pin header, J1 on the green PCB as shown below, momentarily, then releasing. The table below shows the available patterns and the order when stepping through patterns. The module can be reset to "Cycle flash" by shorting the header for greater than 5 seconds and releasing.

CycleFlash (DEFAULT)
 NFPA QuadFlash75
 Steadyburn
 ModelFlash
 ActiveFlash
 FiveFlash70
 QuadFlash70
 TripleFlash70
 DoubleFlash70

Quad Pop Flash75
 Triple Pop Flash75
 SingleFlash375
 SingleFlash250
 SingleFlash150
 FiveFlash150
 QuadFlash150
 DoubleFlash150
 TripleFlash150

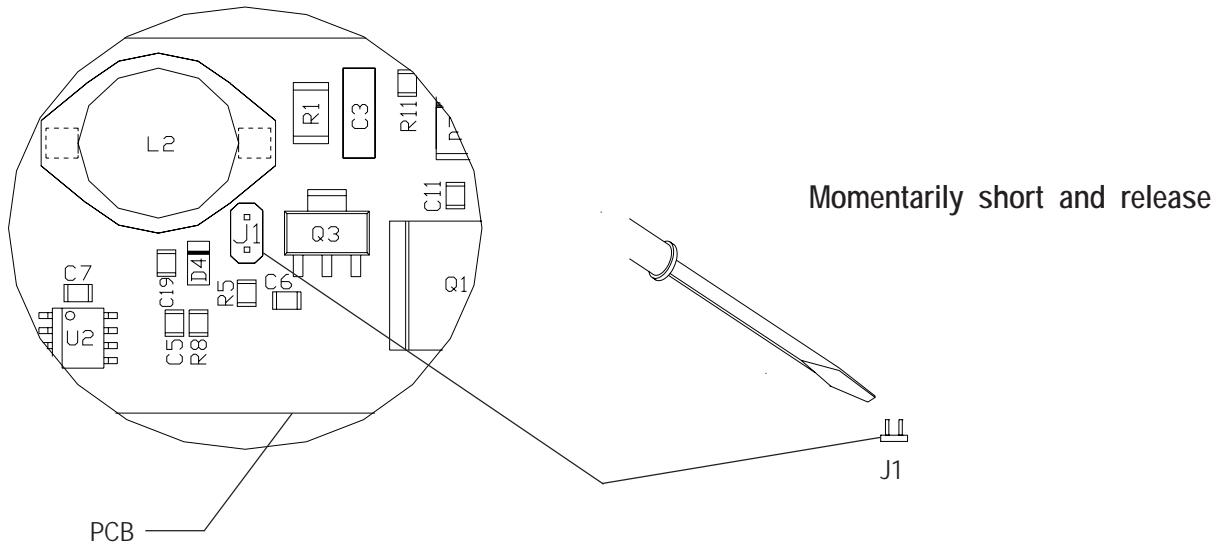

WARRANTY

This product was tested and found to be operational at the time of manufacture. Provided this product is installed and operated in accordance with the manufacturer's recommendations, Code 3®, Inc. guarantees all parts and components, except the halogen lamps, for a period of 1 year, LED lighthouse modules to a period of 5 years (unless otherwise expressed) from the date of purchase or delivery, whichever is later. Units demonstrated to be defective within the warranty period will be repaired or replaced at the factory service center at no cost.

Code 3 shall in no way be liable for other damages including consequential, indirect or special damages whether loss is due to negligence or breach of warranty.

CODE 3 MAKES NO OTHER EXPRESS OR IMPLIED WARRANTY INCLUDING, WITHOUT LIMITATION, WARRANTIES OF FITNESS OR MERCHANTABILITY, WITH RESPECT TO THIS PRODUCT.

PRODUCT RETURNS

In order to provide you with faster service, if you are going to return a product for repair or replacement*, please contact our factory to obtain a Return Goods Authorization Number (RGA number) before you ship the product to Code 3. Write the RGA number clearly on the package near the mailing label. Be sure you use sufficient packing materials to avoid damage to the product being returned while in transit.

*Code 3 reserves the right to repair or replace product at its discretion. Code 3 assumes no responsibility or liability for expenses incurred for the removal and/or reinstallation of products requiring service and/or repair.

CODE 3
 A PUBLIC SAFETY EQUIPMENT COMPANY

Code 3® is a registered trademark of Code 3, Inc.

Revision 0, 11/2007 - Instruction Book Part No. T16345
 ©2004 Code 3, Inc. Printed in USA

Code 3®, Inc.
 10986 N. Warson Road
 St. Louis, Missouri 63114-2029—USA
 Ph. (314) 426-2700 Fax (314) 426-1337

www.code3pse.com