

INSTALLATION & OPERATION MANUAL

8 OUTPUT
PROGRAMMABLE
CONTROLLER

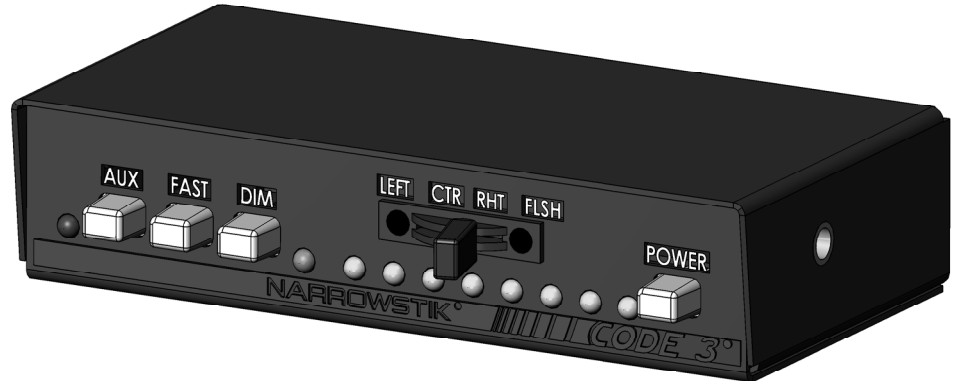

Code 3, Inc., a subsidiary of
Public Safety Equipment, Inc.

CODE 3[®]
INC.
PUBLIC SAFETY EQUIPMENT, INC.

8 OUTPUT PROGRAMMABLE LED NARROWSTIK™ TRICORE® NARROWSTIK™ CONTROLLER

Contents:

Introduction (with warnings)	2
Unpacking & Pre-installation	2
Operation	2-5
Installation	5
Wiring Instruction	5-7
Programming	8-11
Signal Options-Trouble Shooting Guide	12
Notes	13-15
Warranty	16

IMPORTANT:

Read all instructions and warnings before installing and using.

INSTALLER: *This manual must be delivered to the end user of this equipment.*

Introduction

The controller features eight independent outputs and four operating modes (Left, Center-out, Right, Flash) and is specifically designed to operate a stand-alone TriCore® Narrowstik™, LED Narrowstik™, internal lightbar LED Narrowstik™ or Large LED Narrowstik™ as well as LC-Stick versions. The controller features a fast override mode, auxiliary device control, external flash enable, backlighting and a low-intensity (DIM) mode. The low-intensity (DIM) Mode has been designed to work with the new TriCore NarrowStik and with all older NarrowStik models. In addition, the controller has a programming input that gives the end user the ability to program each slide switch position from a group of available traffic directing signals in the Left, Center and Right positions as well as traffic warning patterns in the Flash position (see "Programming" on page 8). **Note: This controller is designed to operate stand-alone LED NarrowStik products. This control head is NOT designed to operate halogen or incandescent ArrowStik products. Attempting to operate the products with this controller could damage the controller outputs.**



The use of this or any warning device does not ensure that all drivers can or will observe or react to an emergency warning signal. Never take the right-of-way for granted. It is your responsibility to be sure you can proceed safely before entering an intersection, driving against traffic, responding at a high rate of speed, or walking on or around traffic lanes.

The effectiveness of this warning device is highly dependent upon correct mounting and wiring. Read and follow the manufacturer's instructions before installing or using this device. The vehicle operator should insure daily that all features of the device operate correctly. In use, the vehicle operator should insure the projection of the warning signal is not blocked by vehicle components (i.e.: open trunks or compartment doors), people, vehicles, or other obstructions.

This equipment is intended for use by authorized personnel only. It is the user's responsibility to understand and obey all laws regarding emergency warning devices. The user should check all applicable city, state and federal laws and regulations.

Code 3, Inc., assumes no liability for any loss resulting from the use of this warning device.

Proper installation is vital to the performance of this warning device and the safe operation of the emergency vehicle. It is important to recognize that the operator of the emergency vehicle is under psychological and physiological stress caused by the emergency situation. The warning device should be installed in such a manner as to: A) Not reduce the output performance of the system, B) Place the controls within convenient reach of the operator so that he can operate the system without losing eye contact with the roadway.

Emergency warning devices often require high electrical voltages and/or currents. Properly protect and use caution around live electrical connections. Grounding or shorting of electrical connections can cause high current arcing, which can cause personal injury and/or severe vehicle damage, including fire.

PROPER INSTALLATION COMBINED WITH OPERATOR TRAINING IN THE PROPER USE OF EMERGENCY WARNING DEVICES IS ESSENTIAL TO INSURE THE SAFETY OF EMERGENCY PERSONNEL AND THE PUBLIC.

Unpacking & Pre-installation

After unpacking the items, carefully inspect the unit and its associated parts for any damage that may have been caused in transit. Report any damage to the carrier immediately.

Installation & Mounting

The product is shipped fully assembled and ready to be installed. Mounting fasteners and brackets have been enclosed in the parts bag. If problems arise during installation, questions can be directed to the Technical Hotline number given on the last page of this manual. This control head is intended to control one Code 3® Narrowstik™.

Control Head Operating Specifications

Electrical

Operating Temperature Range: -40 C to +85 C (-40 F to +185 F)

Operating Voltage Range: 10 to 16 Vdc. Power input has reverse voltage and transient protection.

Operating Current Requirements: 250mA max

Control Output Current Rating: Switch 3 Amps max per output, 50% duty cycle. Connect to LED Narrowstik® modules only.

Mechanical

Depth: 3 1/2 inches not including connector

Width: 6 1/2 inches

Height: 1 1/2 inches

Weight: 1.2 lbs.

Operation

The following sections explain the operation of the control buttons and slide switch as well as the function of the input and output terminals on the 14-position plug and miniature slide switches located on the rear of the unit.

FRONT PANEL CONTROLS

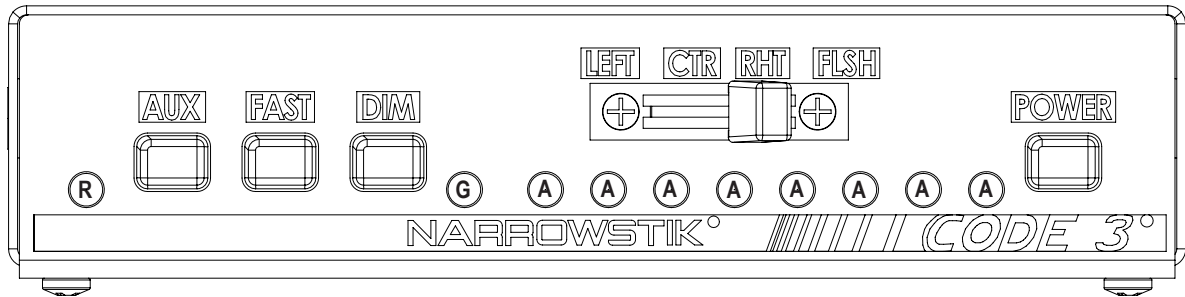

Figure 1 - Front Panel View

Output Indicator LEDs

The eight front panel amber LEDs indicated with an "A" in figure 1, indicate the activity on the outputs for each selection. For example, when in LFT mode the LEDs will cycle ON / OFF from right to left.

AUX

This auxiliary device control was designed specifically to operate customer provided LED modules or other devices not part of the NarrowStik Product. The "AUX" function is independent of the state of the control head ON/OFF POWER button. When the auxiliary input is active, it is indicated by the red LED marked with an "R".

FAST

With any of the directional modes selected (LFT,CTR,RHT) pushing in the button marked FAST will cause the selected directional mode to operate at a faster rate, with the same intensity. The Fast Mode Override has no effect when in the FLASH position.

DIM

Pushing in the button marked DIM will place +12V on the DIM output terminal and white wire, if connected, causing the Narrowstik™ to DIM. In addition, pushing the DIM button will pulse the eight outputs causing the TriCore NarrowStik to DIM. This feature is set using the miniature slide switch on the rear of the unit (See DIM Control Slide Switch on page 6). This is for use when 100% intensity is not desired, or when reduced current draw is desired. DIM operation is indicated by the green LED marked with a "G" in figure 1.

Note: Dimming capabilities are not available with LC-Stick versions.



The Dim setting reduces the light output of emergency warning lights reducing the effectiveness of them especially in brightly lit areas. Failure to use adequate light for the circumstances can cause motorists to fail to see the emergency vehicle and lead to serious personal injury or death. Never use the DIM setting in a brightly lit area. Use of the DIM setting may cause emergency lights to not comply with applicable emergency warning light standards. Use caution when using the DIM setting to assure that motorists can clearly see the emergency vehicle.

LFT, CTR, RHT

With the slide switch in any of these positions the Narrowstik™ will provide a traffic directing signal with either a right-to-left (LFT), a Center-Out (CTR), or a left-to-right (RHT) sequence. The factory default programming is for a building signal starting with either the left most module, the right most module or the two center modules. The control head can be reprogrammed with various traffic directing options for each switch position such as a Building with 3 Flash, Traveling Ball with 3 Flash or a Build/Collapse signal. Refer to the Programming section for more details.

FLSH

With the slide switch in this position the Narrowstik™ will provide a traffic warning signal. The factory default pattern (Flash) alternates the inner most modules with the outer modules. The control head can be reprogrammed with several warning patterns such as Cycle Flash, Sweep Flash, Variable Rate Flash, or multiple rates of Picket Fence and Alternating Patterns. Refer to the programming section for more details.

POWER

The POWER button turns the control head ON/OFF and is a push-on / push-off switch. When the POWER button is activated the control head will perform the currently selected traffic directing or warning pattern. The control head can be operated with the POWER switch in the OFF position by use of the External Flash input. See the External Flash Input section for details.

REAR PANEL CONNECTIONS

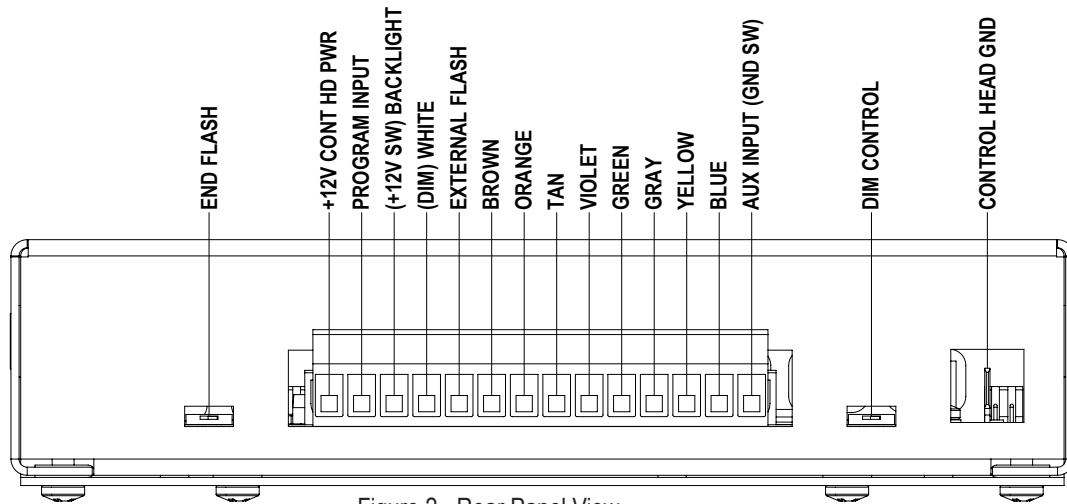

Figure 2 - Rear Panel View

Control Head Power Input

This input provides +12V POWER to the control head. This input will draw approximately 250 mA maximum when the control head is active and the DIM mode is selected. This input is reverse polarity and transient protected.

Program Input

This input is used for programming the control head. With POWER on the control head, pulling this input terminal to GND momentarily until the indicator LEDs (and Narrowstik™ if connected) go out, and then releasing, will step through the available traffic directing signal options for the particular slide switch position currently selected. Holding this input to GND for 5 seconds or longer will reset the control head to the factory default settings. Refer to the Programming section for further details.

Backlighting Input

This input provides power for the backlighting. It is recommended that this input be connected to an IGNITION switched source of +12V or equivalent to prevent battery drain. This input will draw approximately 150 mA @ 12.8V.

Dimming Control Output

This output terminal provides +12V when the DIM button is activated. With the White wire from the 11-wire Narrowstik™ cable connected to this terminal the Narrowstik will run in a reduced intensity (DIM) mode until the DIM switch is turned off. This output is a solid state internally protected output and is designed to operate the Dimming feature only. This output will provide +12V in either position of the DIM Control Slide Switch.

External Flash Control Input

This input will allow remote activation of the FLSH function when the control head POWER switch is off by applying +12V to the designated External Flash input terminal. The active pattern will be the same as that programmed for the FLSH switch position. Turning on the control head, by pushing in the POWER button, activates the currently selected slide switch mode if other than FLSH is selected. This input draws approximately 250 mA maximum when activated and with the DIM mode active.

DIM Control Slide Switch

This switch will enable or disable the PWM feature of this unit. When set in the PWM position, the unit will pulse the eight outputs whenever the DIM push button on the front of the unit is on. The pulsed outputs will cause the TriCore NarrowStik to operate in a reduced intensity (DIM) mode until the DIM switch is turned off. Only use the PWM setting of this switch with the TriCore NarrowStik. Use the STEADY setting for all other NarrowStik Products. Improperly setting this switch will affect the performance of the warning light system. The DIM CONTROL miniature slide switch can be accessed through an opening in the rear of the unit. To adjust this switch use the tip of a pen or small screwdriver to gently slide the actuator to the desired position (see BOTTOM Label).

Note: The DIM CONTROL miniature slide switch has no affect on the Dimming Control Output.

End Flash Slide Switch

This switch will enable or disable the End Flash feature of this unit. When set in the End Flash position, the unit will alternate flash outputs 1 and 8 at a rate of 250ms each whenever LFT, CTR, or RHT is selected with the slide switch on the front of the unit. The END FLASH miniature slide switch can be accessed through an opening in the rear of the unit. To adjust this switch use the tip of a pen or small screwdriver to gently slide the actuator to the desired position (see BOTTOM Label).

Note: The END FLASH feature can only be enabled when the unit is programmed for 5 or 6 head arrow patterns.

LED Module Control Outputs (Brown, Orange, Tan, Violet, Green, Grey, Yellow, Blue)

These eight outputs provide independent control of each LED module in the NarrowStik™. They provide a low-side (GND) signal to each LED module. Connect the designated color from the NarrowStik cable to these terminals.

NOTE: These outputs are designed for LED modules only. DO NOT connect a halogen or incandescent ArrowStik™ to these outputs. Damage may occur to the control outputs.

AUX Input

This input was designed to provide a low-side (GND) signal to an external LED load of up to 3A (two LED modules). This input consists of a fully protected, solid-state FET, with a 3 Amp maximum current capacity. If overloaded, this input will shut down until the overload is removed. To drive higher current loads, this input can be used to control a relay if desired by connecting the low side of the relay coil to this terminal. Pushing in the "AUX" button located on the front panel activates the auxiliary input. The "AUX" function is independent of the state of the control head POWER switch. **NOTE: The "AUX" output will operate with the control head "POWER" button in the ON / OFF position, however, +12V must be applied to the control head Power Input terminal to operate.**

Control Head Ground (GND)

The ground connection is a 1/4" PC mount male quickslide. A 1/4" fully insulated female quickslide is included in the parts bag for connection to a 16 gauge wire or larger. If desired, any 1/4" female quickslide capable of a 16 gauge wire or larger can be used.

Control Head Installation and Wiring

Installation & Mounting

The following procedure outlines mounting of the control head using the enclosed mounting strap and hardware.

1. Position the mounting strap in the selected location. Mark the locations for the mounting hardware (user supplied).
2. Drill the mounting holes in the areas marked.
3. Using the mounting hardware (user supplied), secure the strap to the mounting location.
4. With the bail strap in place, position the control head into the bail until the mounting holes, located in the control head cover, align with the slots in the bail.
5. Using the washers and bolts (supplied), secure the control head into the bail.

Wiring Instructions

Control Head Wiring

The view below, shows the terminal designations for the 14-position plug located on the rear of the unit. Figure 3 on page 6 shows the wiring label located on the bottom of the control head. Connect the wires from the NarrowStik cable and user supplied auxiliary function wires as shown in the wiring diagram. Recommended wire size and fusing is also shown in the diagram. The control head GND will be connected using the 1/4" quickslide included with the unit. Refer to the Operation section, page 3, for details on individual wire functions.

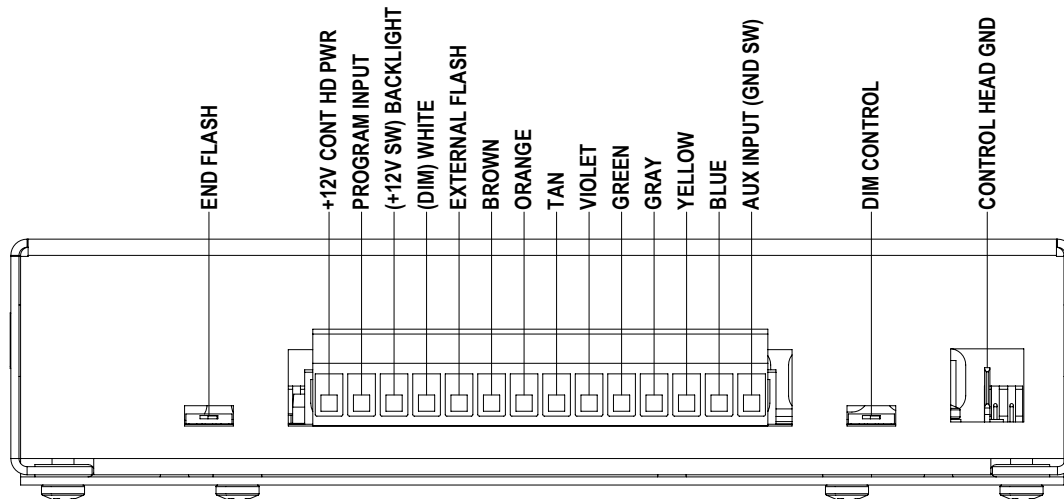

Rear Panel View

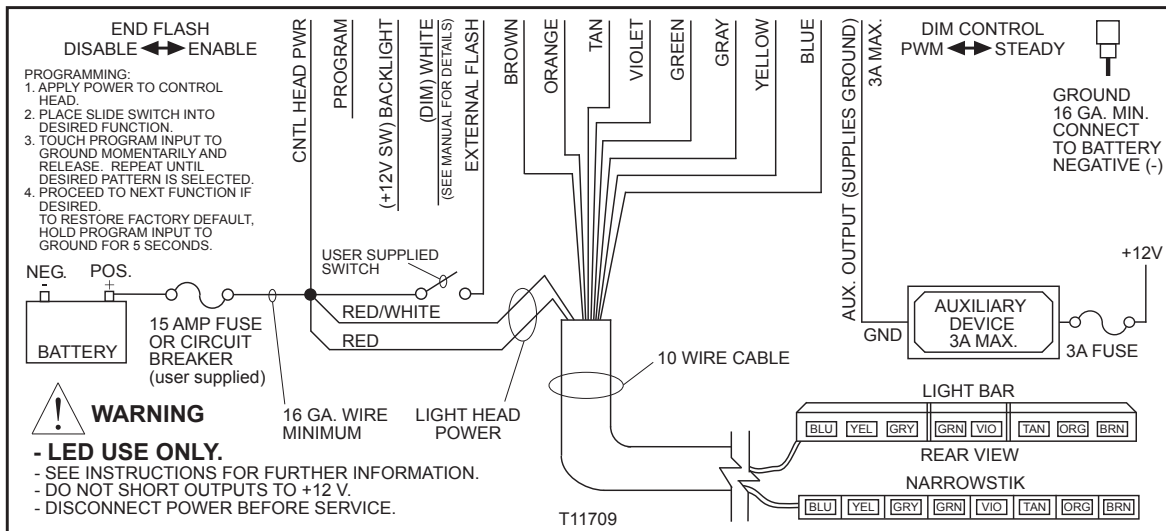

Bottom View (wiring label)

Figure 3- Rear panel connections and wiring label located on bottom of the control head.



WARNING!

Larger wires and tight connections will provide longer service life for components. For high current wires it is highly recommended that terminal blocks or soldered connections be used with shrink tubing to protect the connections. Do not use insulation displacement connectors (e.g. 3M® Scotchlock type connectors). Route wiring using grommets and sealant when passing through compartment walls. Minimize the number of splices to reduce voltage drop. High ambient temperatures (e.g. underhood) will significantly reduce the current carrying capacity of wires, fuses, and circuit breakers. Use "SXL" type wire in engine compartment. All wiring should conform to the minimum wire size and other recommendations of the manufacturer and be protected from moving parts and hot surfaces. Looms, grommets, cable ties, and similar installation hardware should be used to anchor and protect all wiring. Fuses or circuit breakers should be located as close to the power takeoff points as possible and properly sized to protect the wiring and devices. Particular attention should be paid to the location and method of making electrical connections and splices to protect these points from corrosion and loss of conductivity. Ground terminations should only be made to substantial chassis components, preferably directly to the vehicle battery. The user should install a fuse sized to approximately 125% of the maximum Amp capacity in the supply line to protect against short circuits. For example, a 30 Amp fuse should carry a maximum of 24 Amps. **DO NOT USE 1/4" DIAMETER GLASS FUSES AS THEY ARE NOT SUITABLE FOR CONTINUOUS DUTY IN SIZES ABOVE 15 AMPS.** Circuit breakers are very sensitive to high temperatures and will "false trip" when mounted in hot environments or operated close to their capacity.

Narrowstik™ / WingMan™ / LC-Stik / Large LED Narrowstik™ / Lightbar Wire Designations

The manual for the Narrowstik (and other LED models) contains detailed information related to wiring and mounting of the Narrowstik itself. Refer to figure 4, on page 7, for additional information on the function of each wire in the 10-wire and 11-wire cable and Narrowstik.

Special Wiring Instructions

Front facing wiring of the Narrowstik™

The standard wiring method is for a rear-facing, driver side cable exit system as shown in figure 4. If it is desired to mount the device as a front-facing, or passenger side cable exit, system the LED control wires will have to be reversed as indicated. The connector shown in figure 4 DOES NOT have the wires reversed. The connector shown has standard rear facing cable exit wiring.

Wiring for Narrowstik Models with outboard flashing modules:

If you want the modules in the outboard positions to alternate during any arrow pattern (LFT, CTR, RHT), set the End Flash slide switch to the ENABLE position and program the unit for 5 or 6 head arrow patterns. There are no changes to how the NarrowStik is wired to the control head.

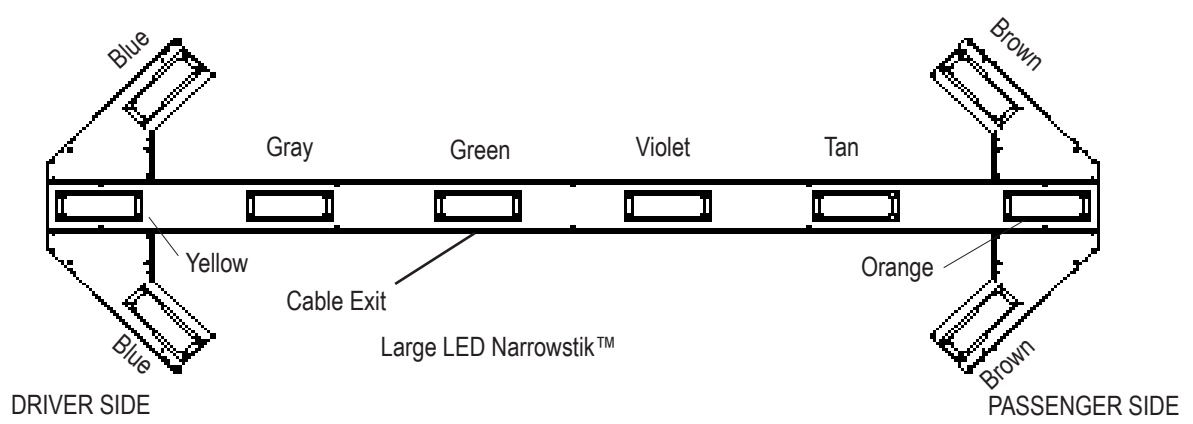
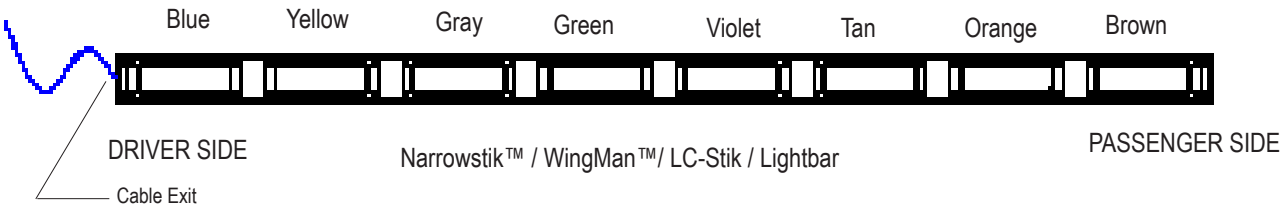

10-Wire Cable Wire Designations	
Red, Red / White	LED module Power +12V
Brown	INDIVIDUAL LED MODULE CONTROL WIRES
Orange	
Tan	
Violet	
Green	
Gray	
Yellow	
Blue	

11-Wire Cable Wire Designations	
Red, Red / White	LED module Power +12V
White	DIM Control wire
Brown	INDIVIDUAL LED MODULE CONTROL WIRES
Orange	
Tan	
Violet	
Green	
Gray	
Yellow	
Blue	

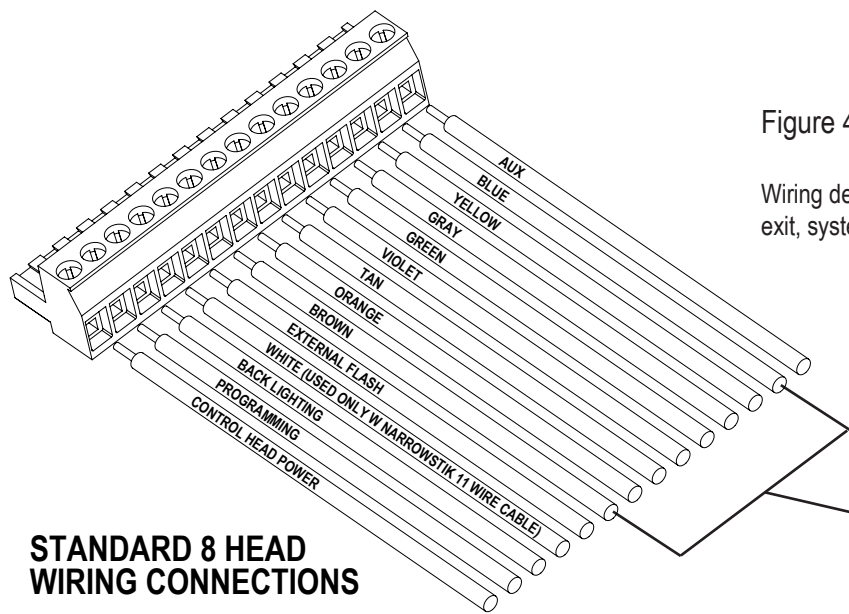

Figure 4
Wiring designations for a Rear Facing, Driver Side Cable exit, system.

Note: For a passenger side cable exit, or front facing system the LED control wires will need to be reversed. Wires are not shown reversed.

STANDARD 8 HEAD WIRING CONNECTIONS

Control Head Programming

Introduction

The 8 Output LED Narrowstik™ controller was designed to offer independent 8 output control along with user programmability to allow selection from a variety of traffic directing signals and traffic warning options. This allows the greatest flexibility when controlling any one of the various Narrowstik™ configurations available. The end user can match the desired signal to a particular Narrowstik™ configuration whether it be an 8, 6 or 5 head configuration. The controller can also be setup to replace a current 5 output controller for those users that have a 7 wire Narrowstik™ system. Most controllers will come from the factory with the factory default pattern configuration installed. The default configuration will be for an 8 head system with all building patterns (Building 8 HD). If it is desired to change any pattern in any of the slide switch positions (LFT, CTR, RHT or FLSH) or if you have other than an 8 head system (6 or 5 head) and you want to optimize the patterns for your particular configuration then follow the programming procedure outlined below.

Programming

As mentioned previously, most control heads will come from the factory set in the default configuration which is the Building 8HD (output) configuration. See Table 1, page 12. The current configuration can be checked by observing the operation of the front panel indicator LED's with the control head powered. Figure 6, Page 11, shows how to use the indicator LEDs on the front panel to determine if the control head is in an 8, 6 or 5 head configuration.

Note: It will be important to view the front panel indicator LEDs during the programming procedure while stepping through the signal options. Review figure 6, on page 11, completely before proceeding. Signals are available for 8, 6 or 5 head configurations.

Procedure

The following procedure will assume that you are programming a control head shipped for use with a Narrowsik or light bar. For programming a control head shipped for use with a Large LED Narrowstik™ (S23179), the procedure will be the same but the available patterns are different (see Table 2, Page 12).

Refer to the traffic directing signal options in Table 1, page 12, for the following procedure.

STEP 1

The programming input, located on the rear panel 14-position plug (see rear panel view on page 4 or 5), is activated by pulling this terminal to GND. You will need to either temporarily connect a wire to this terminal or find another means to supply **GND** to this terminal during the programming process.

STEP 2

Power-up the control head and place the front panel slide switch in the position that you wish to program (LFT,CTR,RHT,FLSH). At this point you can observe the front panel LED indicators. Using figure 6 on page 11 and Table 1 on page 12, determine what pattern and configuration the control head is currently in, (if not in the factory default).

Alternatively, if desired, you can hold the programming terminal to GND until the front panel indicator LEDs go out (and the Narrowstik if connected) and HOLD for 5 seconds, or longer, and then release to put the unit in the factory default configuration. All eight indicator LEDs (and the NarrowStik if connected) will flash 3 times to indicate that the unit is in the factory default configuration. Resetting the unit to the factory default while operating any arrow (LFT, CTR, RHT) pattern will reset all arrow patterns. Resetting the unit to the factory default while operating the FLSH pattern will only reset the traffic warning pattern.

Once the pattern / configuration has been determined, or you have reset the unit to the factory default, proceed to Step 3.

STEP 3

Refer to Table 1, on Page 12. This table shows the available patterns for each slide switch position and their order in program memory. Notice that for the LFT, CTR and RHT positions there are four (4) pattern choices; Building, Building with 3 Flash, Traveling with 3 Flash, and Build/Collapse and three (3) configurations; 8, 6, or 5HD. There are a total of twelve possible selections (1-12) and then you return to the top selection, Building 8 HD. Starting from the first pattern in Table 1 you can step through each pattern, (1-4) for an 8HD, (5-8) for a 5HD and (9-12) for a 6 HD configuration, by momentarily holding the programming input terminal to GND for 1-2 sec, until the indicator LEDs (and Narrowstik if connected) are OFF, and then releasing. This will step the control head to the next pattern in Table 1 for the selected slide switch position. The new pattern is automatically stored each time.

Note: Remember to HOLD the programming terminal to GND until you are sure the indicator LEDs, and Narrowstik™ (if connected), are OFF before releasing the GND from the programming terminal.

STEP 3 Cont:

When the FLSH function is selected the same procedure applies as above, but you will notice in Table 1, that the patterns are not grouped by whether it is an 8, 6 or 5 head configuration. These are traffic warning patterns and work equally well for any configuration of LED modules. There are a total of nineteen (1-19) traffic warning patterns available. When you have programmed in the desired pattern for the selected function proceed to Step 4.

Note: The pattern selected for the FLSH position will also be the active pattern when the External Flash input is activated.

STEP 4

Move the slide switch to another position and repeat the previous steps until all of the functions are programmed as desired.

Programming a Large LED Narrowstik™ Control Head

The control head shipped for use with the Large LED Narrowstik (S23179) is equipped with a different program due to the fact that these units are shipped in one configuration (10 head). All of the programming steps outlined above are still correct but there will be only an 8 HD (output) configuration. See Table 2, page 12 for pattern details.

Retrofitting the 8 output Narrowstik™ Controller to an existing 7-wire Narrowstik System

To retrofit the 8 output controller to an existing 7-wire Narrowstik system simply connect the five control wires (Brown, Orange, Violet, Yellow and Blue) into the terminals on the 8 Output Controller with the same color designations (see figure 5 PGs 9 & 10). Then reprogram the controller for 5 output / HD operation with the desired pattern. Consult the factory for retrofitting to a 7-wire Large LED Narrowstik.

Figure 5

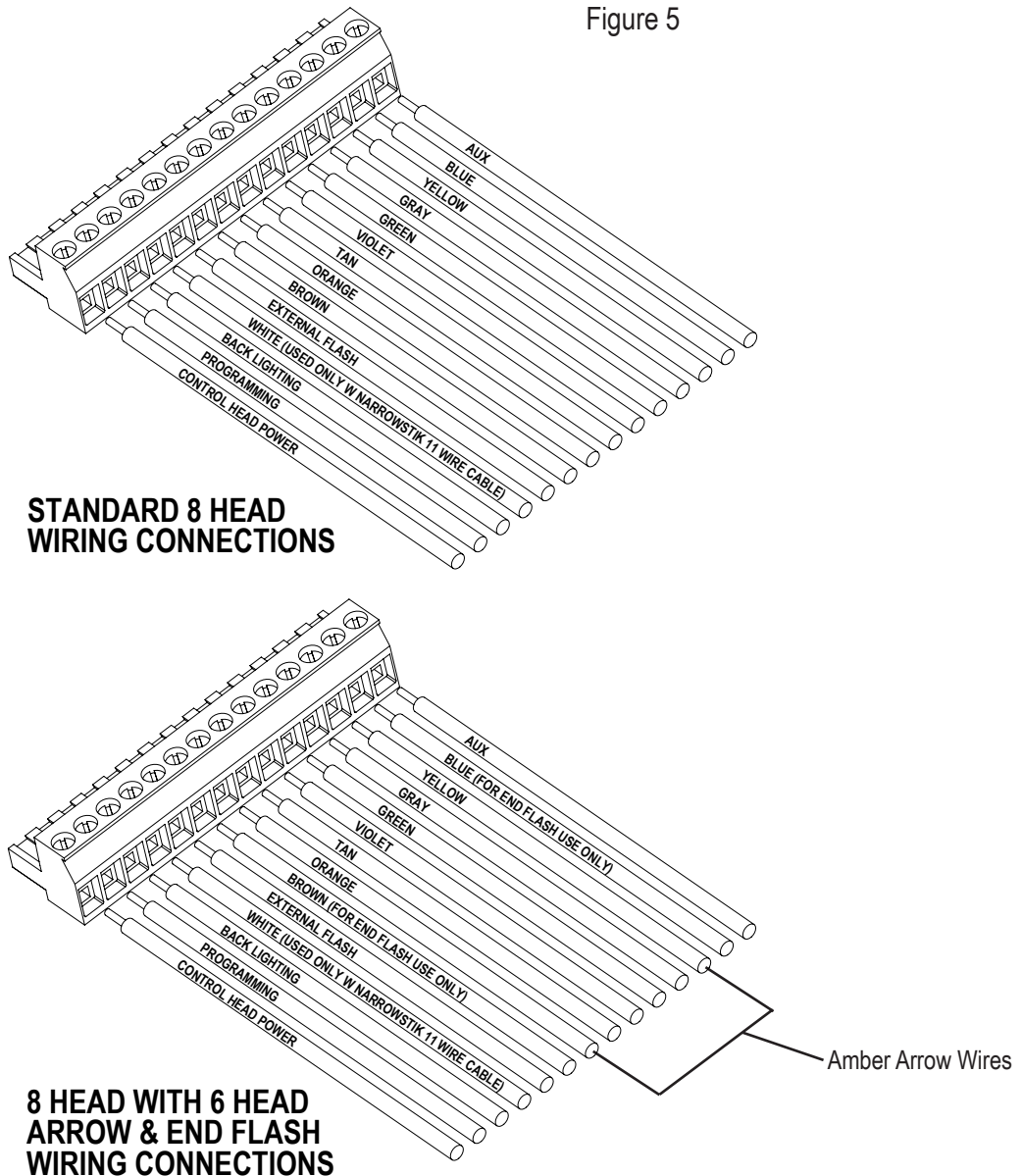
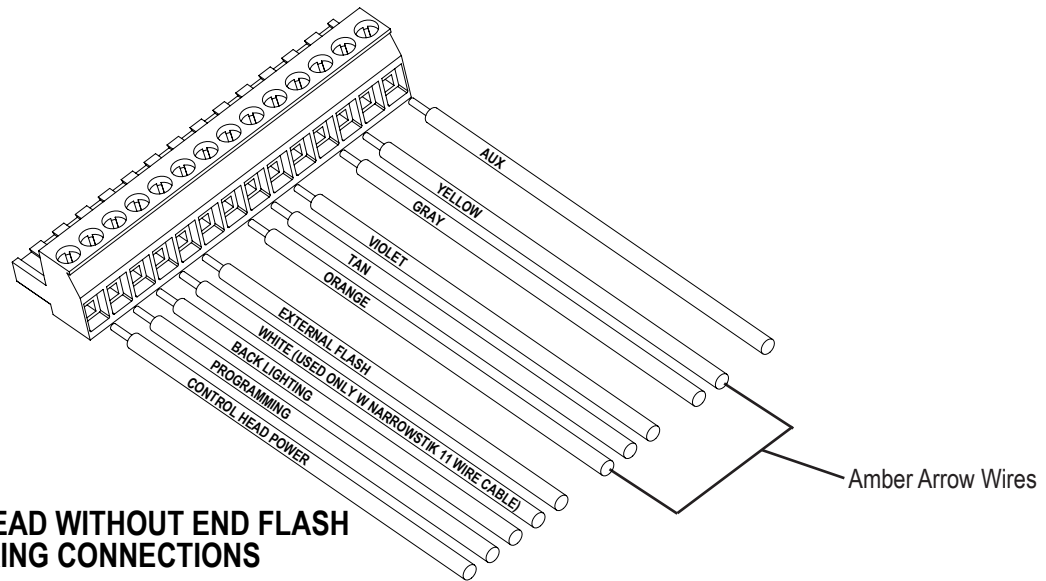
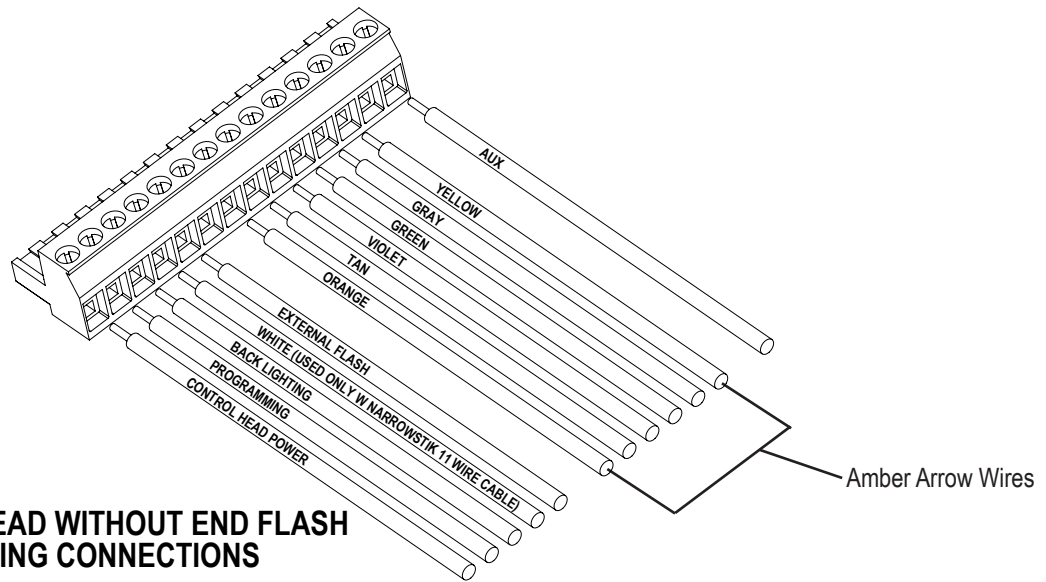
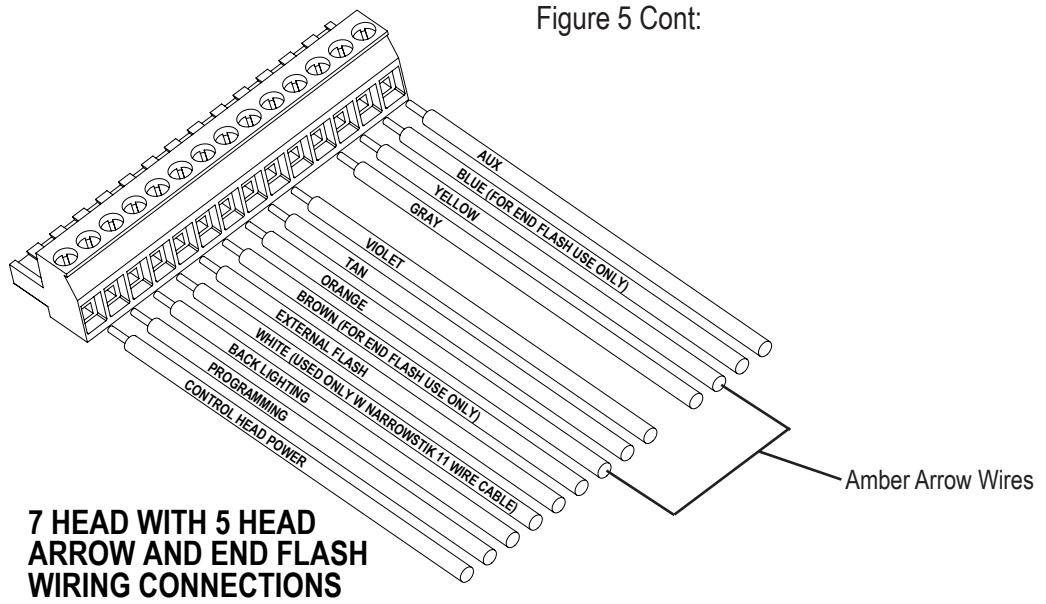
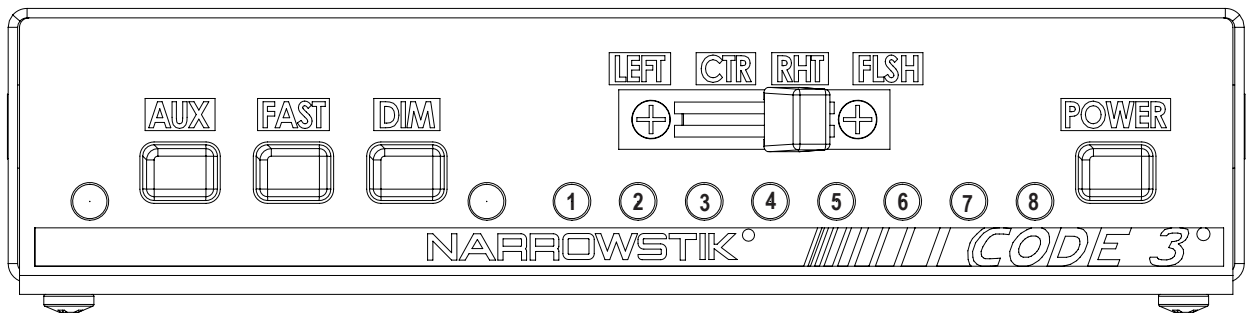

Figure 5 Cont:





8 Output / Head Operation

8 Output / Head operation can be determined by observing the Front Panel LED indicators when powered. All indicator LEDs will function independently as designated by 1, 2, 3, 4, 5, 6, 7, 8.

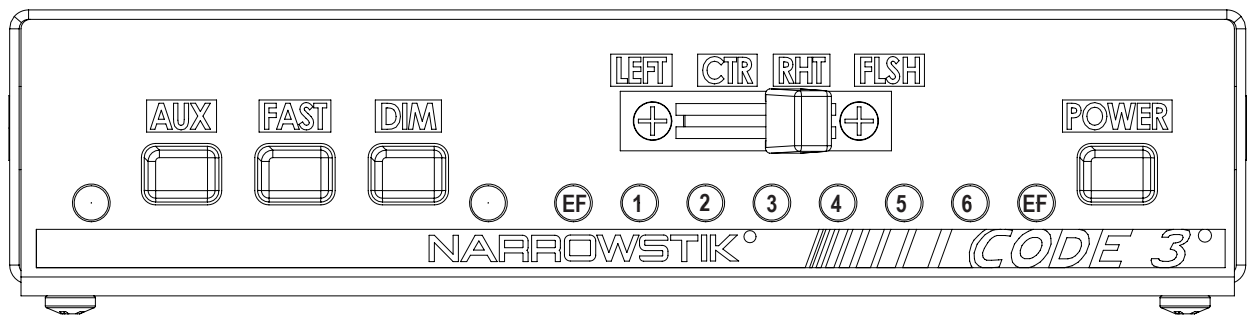

6 Output / Head Operation

6 Output / Head operation can be determined by observing the Front Panel LED indicators when powered. All indicator LEDs designated by the same number will function together 1, 2, 3, 4, 5, 6. The two indicator LEDs designated by EF are reserved for use in systems where the outboard positions will alternate during any arrow (LFT, CTR, RHT) pattern (see End Flash slide switch on page 4)

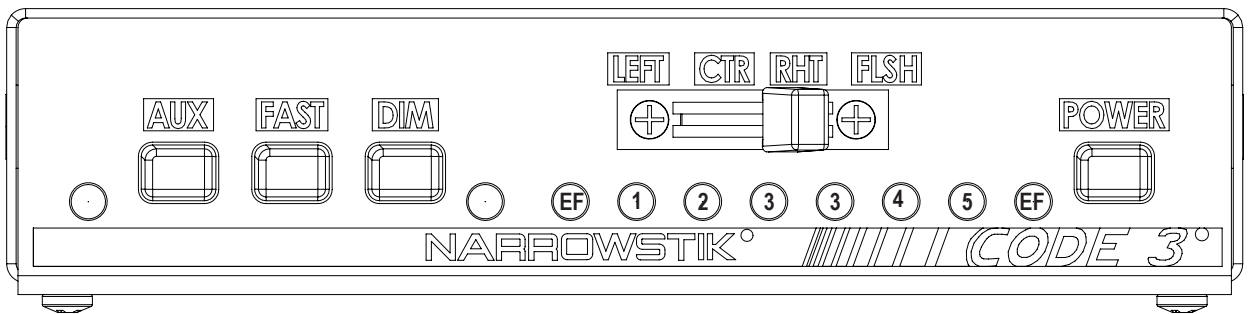

5 Output / Head Operation

5 Output / Head operation can be determined by observing the Front Panel LED indicators when powered. All indicator LEDs designated by the same number will function together 1, 2, 3-3, 4, 5. The two indicator LEDs designated by EF are reserved for use in systems where the outboard positions will alternate during any arrow (LFT, CTR, RHT) pattern (see End Flash Slide Switch on page 4)

Figure 6
Front Panel indicator LED operation for 8, 6 or 5 head operation

Traffic Directing / Traffic Warning Pattern Options

WARNING!



This Product contains high intensity TriCore devices. To prevent eye damage, DO NOT stare into light beam at close range.

Slide Switch Position	LEFT (LFT)	CENTER-OUT (CTR)	RIGHT (RHT)	FLASH (FLSH)
(Factory Default) 1. 2. 3. 4.	Building 8HD Building 8HD, 3 Flash Traveling Ball 8HD, 3 Flash Build/Collapse 8HD	Building 8HD Building 8HD, 3 Flash Traveling Ball 8HD, 3 Flash Build/Collapse 8HD	Building 8HD Building 8HD, 3 Flash Traveling Ball 8HD, 3 Flash Build/Collapse 8HD	Single Flash In/Out Slow Single Flash In/Out Fast Single Flash Simultaneous Slow Single Flash Simultaneous Fast
5. 6. 7. 8.	Building 5HD Building 5HD, 3 Flash Traveling Ball 5HD, 3 Flash Build/Collapse 5HD	Building 5HD Building 5HD, 3 Flash Traveling Ball 5HD, 3 Flash Build/Collapse 5HD	Building 5HD Building 5HD, 3 Flash Traveling Ball 5HD, 3 Flash Build/Collapse 5HD	Quad Flash Picket Fence Fast Quad Flash Alternating Fast Quad Flash Picket Fence Slow Quad Flash Alternating Slow
9. 10. 11. 12.	Building 6HD Building 6HD, 3 Flash Traveling Ball 6HD, 3 Flash Build/Collapse 6HD	Building 6HD Building 6HD, 3 Flash Traveling Ball 6HD, 3 Flash Build/Collapse 6HD	Building 6HD Building 6HD, 3 Flash Traveling Ball 6HD, 3 Flash Build/Collapse 6HD	Single Flash Picket Fence Fast Single Flash Alternating Fast Single Flash Picket Fence Slow Single Flash Alternating Slow
13. 14. 15. 16. 17. 18. 19.				Six Flash Picket Fence Fast Six Flash Alternating Fast Six Flash Picket Fence Slow Six Flash Alternating Slow Variable Rate Picket Fence Cycle Flash (multiple patterns) Sweep Flash

Table 1 - Signal options for LED Narrowstik™ / LC-Stik / Lightbars

Slide Switch Position	LEFT (LFT)	CENTER-OUT (CTR)	RIGHT (RHT)	FLASH (FLSH)
(Factory Default) 1. 2. 3. 4.	Building 8HD Sequencing 8HD Bouncing Ball 8HD All Flash 8HD	Building 8HD Sequencing 8HD Bouncing Ball 8HD All Flash 8HD	Building 8HD Sequencing 8HD Bouncing Ball 8HD All Flash 8HD	Flash Fastflash Sweepflash

Table 2 - Signal options for Large LED Narrowstik™ (S23179) version.

Trouble Shooting Guide

PROBLEM	CAUSE	REMEDY
NarrowStik™ does not function when turned on.	Plug in rear of control box is loose or disconnected. Faulty ground (earth) connection. Faulty power connection. Control box is damaged.	Reconnect plug. Verify ground (earth) connection. Verify +12Vdc connections. Check connections. If problem still exists, call Technical Hotline.
One or more lighthead do not light and LED's on control box function correctly.	Failed lighthead. Bad wiring connection.	Replace Lighthead Verify connections.
One or more lighthead do not light and LED's on control head do not function.	Control box is damaged.	Return control head to PSE or call Technical Hotline.
LED's on control box illuminate continuously.	Control box is damaged.	Return control head to PSE or call Technical Hotline.

Notes:

Notes:

Notes:

WARRANTY

This product with TriCore® Technology was tested and found to be operational at the time of manufacture. Provided this product is installed and operated in accordance with the manufacturer's recommendations, Code 3®, Inc. warrants all parts and components (with the exception of all incandescent and halogen bulbs) of the product to be free of defects in material and workmanship for a period of one (1) year and TriCore® light heads for a period of five (5) years from the date of purchase. This Warranty excludes normal wear & tear. Units demonstrated to be defective within the warranty period will be repaired or replaced at the factory service center at no cost. Code 3, Inc. will return the repaired product with transportation cost prepaid. Code 3, Inc. assumes no liability for expenses incurred in the packaging, handling, and shipping of the product to the Factory Technical Service Department for repair. For in-warranty product return authorization, questions regarding product warranty coverage or questions regarding out-of-warranty repair quotes, contact the Factory Technical Service Department.

The TriCore® light heads are sealed as part of the quality control process. This Warranty is void if, in the judgment of Code 3, Inc. (1) an attempt has been made to break the light head seal or repair the light head, and/or (2) the product has been used with inappropriate or inadequate wiring or circuit protection, and/or (3) the product has failed as a result of abuse or unusual use and/or accidents.

CODE 3, INC. SHALL IN NO WAY BE LIABLE FOR ANY OTHER DAMAGES RELATING TO THE PRODUCT INCLUDING BUT NOT LIMITED TO CONSEQUENTIAL, INCIDENTAL, INDIRECT OR SPECIAL DAMAGES OR LOST PROFITS OR REVENUE; NOR ANY EXPENSES INCURRED IN THE REMOVAL AND/OR RE-INSTALLATION OF PRODUCTS REQUIRING SERVICE AND/OR REPAIR.

EXCEPT AS SET FORTH ABOVE, CODE 3, INC. MAKES NO OTHER EXPRESS OR IMPLIED WARRANTIES WHATSOEVER, INCLUDING, WITHOUT LIMITATION, WARRANTIES OF FITNESS FOR A PARTICULAR PURPOSE OR MERCHANTABILITY, WITH RESPECT TO THIS PRODUCT.

PRODUCT RETURNS

If a product must be returned for repair or replacement*, please contact our factory to obtain a Return Goods Authorization Number (RGA number) before you ship the product to Code 3®, Inc. Write the RGA number clearly on the package near the mailing label. Be sure you use sufficient packing materials to avoid damage to the product being returned while in transit.

*Code 3®, Inc. reserves the right to repair or replace at its discretion. Code 3®, Inc. assumes no responsibility or liability for expenses incurred for the removal and /or reinstallation of products requiring service and/or repair.; nor for the packaging, handling, and shipping; nor for the handling of products returned to sender after the service has been rendered.

For Technical Support / Service, please call 314-996-2800.

Code 3®, Inc., a subsidiary of
Public Safety Equipment, Inc.

CODE 3[®]
PUBLIC SAFETY EQUIPMENT, INC.

Code 3, Inc.
10986 N. Warson Road
St. Louis, Missouri 63114-2029—USA
www.code3pse.com