

# INSTALLATION & OPERATION MANUAL



5000 SERIES  
LIGHT BAR

**CODE 3**<sup>®</sup>  
PUBLIC SAFETY EQUIPMENT, INC.

**XL5000**<sup>™</sup>

LIGHT BAR

## Contents:

Introduction .....	2
Unpacking & Pre-Installation .....	2
Siren Speakers .....	2
Mounting Light Bar .....	3
Wiring Instructions .....	3
Maintenance .....	4
Options .....	6
Warranty .....	8

**IMPORTANT:** *Read all instructions and warnings before installing and using.*  
**INSTALLER:** *This manual must be delivered to the end user of this equipment.*

# Introduction

The XL 5000™ lightbars provide a highly visible warning light that meets or exceeds all SAE specifications. The bars have a strong extruded aluminum frame and shock resistant polycarbonate lenses. The bars are of a modular design that allows them to be customized to meet any requirement.



**WARNING!**

The use of this or any warning device does not insure that all drivers can or will observe or react to an emergency warning signal. Never take the right-of-way for granted. It is your responsibility to be sure you can proceed safely before entering an intersection, driving against traffic, responding at a high rate of speed, or walking on or around traffic lanes. The effectiveness of this warning device is highly dependent upon correct mounting and wiring. Read and follow the manufacturer's instructions before installing or using this device. The vehicle operator should insure daily that all features of the device operate correctly. In use, the vehicle operator should insure the projection of the warning signal is not blocked by vehicle components (i.e.: open trunks or compartment doors), people, vehicles, or other obstructions.

This equipment is intended for use by authorized personnel only. It is the user's responsibility to understand and obey all laws regarding emergency warning devices. The user should check all applicable city, state and federal laws and regulations.

Public Safety Equipment, Inc., assumes no liability for any loss resulting from the use of this warning device.

Proper installation is vital to the performance of this warning device and the safe operation of the emergency vehicle. It is important to recognize that the operator of the emergency vehicle is under psychological and physiological stress caused by the emergency situation. The warning device should be installed in such a manner as to: A) Not reduce the output performance of the system, B) Place the controls within convenient reach of the operator so that he can operate the system without losing eye contact with the roadway.

Emergency warning devices often require high electrical voltages and/or currents. Properly protect and use caution around live electrical connections. Grounding or shorting of electrical connections can cause high current arcing, which can cause personal injury and/or severe vehicle damage, including fire.

**PROPER INSTALLATION COMBINED WITH OPERATOR TRAINING IN THE PROPER USE OF EMERGENCY WARNING DEVICES IS ESSENTIAL TO INSURE THE SAFETY OF EMERGENCY PERSONNEL AND THE PUBLIC.**

## Unpacking & Pre-installation

Carefully remove the light bar from the shipping carton and place on a flat surface, taking care not to damage the wire cable coming out of the bottom. Examine the unit for transit damage, cracked lenses, dented speaker cover, etc. If convenient, you may wish to bench test the unit before installing. Before applying voltage to the bar, be sure you have read and understand the wiring instructions attached to the cable. Standard light bars operate on 12 volt D.C. negative ground (earth) systems only. If you have a positive ground (earth) vehicle, or any other type of system, and have not ordered a specially wired bar, contact the factory for instructions.

## Siren Speakers

It is generally easier to install siren speakers before mounting the bar on the vehicle. No. 8 sheet metal screws will easily break through the metallic tape and thread into the prepunched holes in the frame. To install a speaker, remove the hex head screws that secure the center cover to the frame and remove it to reveal a prewired terminal block. The center area is 1/8" aluminum and may be drilled almost anywhere, if other than a Code 3 speaker is used. Before drilling, however, we suggest turning the light bar over and removing the wire track cover plate from the bottom of the frame by removing the retaining screws. With the wires exposed, drill carefully to avoid damaging the wires. After mounting the speaker and connecting the leads to the terminal block, reinstall the wire track cover. Replace the center cover.

When using two siren speakers, follow speaker manufacturer's instructions for correct phasing of speakers.



**WARNING!**  
**SIREN PRODUCTS:**

Sirens are an integral part of an effective audio/visual emergency warning system. However, sirens are only short range secondary warning devices. The use of a siren does not insure that all drivers can or will observe or react to an emergency warning signal, particularly at long distances or when either vehicle is traveling at a high rate of speed. Sirens should only be used in a combination with effective warning lights and never relied upon as a sole warning signal. Never take the right of way for granted. It is your responsibility to be sure you can proceed safely before entering an intersection, driving against traffic, or responding at a high rate of speed.

The effectiveness of this warning device is highly dependent upon correct mounting and wiring. Read and follow the manufacturer's instructions before installing or using this device. The vehicle operator should check the equipment daily to insure that all features of the device operate correctly.

To be effective, sirens must produce high sound levels that potentially can inflict hearing damage. Installers should be warned to wear hearing protection, clear bystanders from the area and do not to operate the siren indoors during testing. Vehicle operators and occupants should assess their exposure to siren noise and determine what steps, such as consultation with professionals or us of hearing protection should be implemented to protect their hearing.

This equipment is intended for use by authorized personnel only. It is the user's responsibility to understand and obey all laws regarding emergency warning devices. The user should check all applicable city, state and federal laws and regulations.

Public Safety Equipment, Inc., assumes no liability for any loss resulting from the use of this warning device.

Proper installation is vital to the performance of this warning device and the safe operation of the emergency vehicle. It is important to recognize that the operator of the emergency vehicle is under psychological and physiological stress caused by the emergency situation. The siren system should be installed in such a manner as to: A) Not reduce the acoustical performance of the system, B) Limit as much as practical the noise level in the passenger compartment of the vehicle. C) Place the controls within convenient reach of the operator so that he can operate the system without losing eye contact with the roadway.

Emergency warning devices often require high electrical voltages and/or currents. Properly protect and use caution around live electrical connections. Grounding or shorting of electrical connections can cause high current arcing, which can cause personal injury and/or severe vehicle damage, including fire.

**PROPER INSTALLATION COMBINED WITH OPERATOR TRAINING IN THE PROPER USE OF EMERGENCY WARNING DEVICES IS ESSENTIAL TO INSURE THE SAFETY OF EMERGENCY PERSONNEL AND THE PUBLIC.**

## Mounting Light Bar

### Mounting

To mount lightbar refer to instructions included with the mounting kit.

### Remounting

When moving the light bar from one vehicle to another, we suggest that new 5/16" mounting bolts and rubber feet be used. These are standard hardware items that can usually be found at any hardware store, or they can be ordered from the factory. The special hooks are stainless steel and should be saved and reused.

**NOTE!** If different holes must be used to mount the brackets, tape over the usual holes with duct tape on the inside to prevent dirt and water from entering the light bar.

## Wiring Instruction

Run at least a #10 AWG wire to the battery or to the stud on the battery side of the starter solenoid or alternator. Be sure to calculate light bar's power draw and provide proper protection for short circuits. Below is a quick chart and equation for calculating light bar load.

35 Watt Lamp = 3 Amp Load  
50 Watt Lamp = 4 Amp Load  
100 Watt Lamp = 8 Amp Load  
Motors and Electronics Boxes = Negligible Load

Total watts in light bar divided by 13 volts equals amperage draw or:

Watts / 13 Volts = Amp Draw

If the light bar has a speaker section, the blue wires go to the siren amplifier and are to be connected in accordance with the siren manufacturer's instructions. Test the unit for proper operation.

Route the wiring cable into the engine or passenger compartment, taking care to use grommets and to apply sealant around openings to keep water out. It is advisable to leave an extra loop of cable when installing the light bar to allow for future changes or reinstallations. Connect the black lead to a solid frame ground (earth), preferably, the (-) or ground (earth) side of the battery and bring the other wires to the control head or switches. Connect the wires to the control head or switch (as directed by the wiring instructions on the cable). **Caution - Operating a siren with a live speaker can inflict hearing damage--always use hearing protection.**



Larger wires and tight connections will provide longer service life for components. For high current wires it is highly recommended that terminal blocks or soldered connections be used with shrink tubing to protect the connections. Do not use insulation displacement connectors (e.g. 3M® Scotchlock type connectors). Route wiring using grommets and sealant when passing through compartment walls. Minimize the number of splices to reduce voltage drop. High ambient temperatures (e.g. under hood) will significantly reduce the current carrying capacity of wires, fuses, and circuit breakers. Use "SXL" type wire in engine compartment. All wiring should conform to the minimum wire size and other recommendations of the manufacturer and be protected from moving parts and hot surfaces. Looms, grommets, cable ties, and similar installation hardware should be used to anchor and protect all wiring.

Fuses or circuit breakers should be located as close to the power takeoff points as possible and properly sized to protect the wiring and devices.

Particular attention should be paid to the location and method of making electrical connections and splices to protect these points from corrosion and loss of conductivity. Ground terminations should only be made to substantial chassis components, preferably directly to the vehicle battery.

The user should install a fuse sized to approximately 125% of the maximum Amp capacity in the supply line to protect against short circuits. For example, a 30 Amp fuse should carry a maximum of 24 Amps. **DO NOT USE 1/4" DIAMETER GLASS FUSES AS THEY ARE NOT SUITABLE FOR CONTINUOUS DUTY IN SIZES ABOVE 15 AMPS.** Circuit breakers are very sensitive to high temperatures and will "false trip" when mounted in hot environments or operated close to their capacity.

## Maintenance

### Lens Removal

Force 4™ XL 5000™ series light bars are assembled with 1/4" Hex Head Screws. A 1/4" Socket or Nut Driver is ideal, but a phillips screwdriver may be used.

## Force 4™ XL™ Light Bars

Remove the hex head screws along the lower front and rear edge of the speaker cover. Remove the speaker cover by carefully pulling slightly forward and upward from the front lower edge, then lift it off to the rear, taking care not to drag the cover on the lenses. Remove all of the screws from the lower front and rear edge of the lenses and carefully lift them off. NOTE: If ambulance clips have been installed at the rear of the lenses, only the front screws need to be taken off. Then lift the lens up and over the clips.

## Force 4™ XL™ Beacons

Remove all screws securing the lens and lift off.

## Reassembly - All Products

When reassembling, check the lens perimeter gasket and replace if damaged. To reassemble, reverse the previous procedures. It should be noted that a slight downward pressure on the lens may be required during assembly. All screws should be **hand tight**. Excessive torque is not needed and may strip hole.

## Lamp Replacement

Remove the lens as outlined above. Next inspect the bulb and compare to Figure 1 to determine bulb type. It may be necessary to remove any rotating or cylindrical filters to make access easier.



**WARNING!**

Lamps are extremely hot! Allow to cool completely before attempting to remove. Gloves and eye protection should be worn when handling halogen lamps as they are pressurized and accidental breakage can result in flying glass.

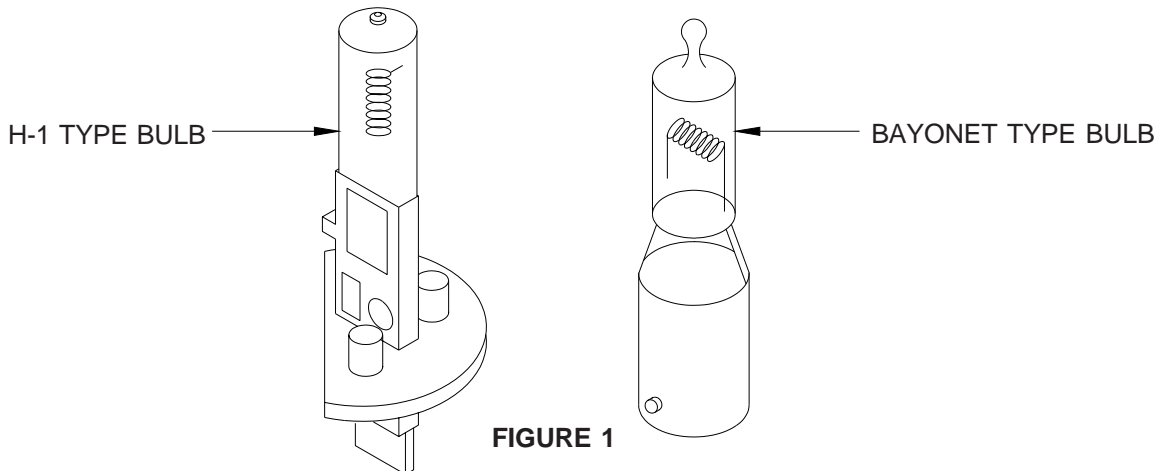

**H-1:** First grasp bulb at base and turn until retaining clip is accessible. Using a blade screwdriver, remove the retaining clip and pull bulb straight up. Grasp the power lead with long nose pliers and remove the bulb. Replace with new bulb, insuring that the power lead is fully inserted into the bulb. Insert into the rotator and insure the retaining clip is fully inserted.

**S-795 (Bayonet Style):** Push down and turn to remove bulb. Install new bulb the same way.

**DO NOT LUBRICATE:** The bearings used in rotating lights are permanently lubricated with a high-performance synthetic oil that is not compatible with many lubricants. Mixing lubricants may result in a gummy mixture that will freeze in cold weather.

# Options

Many options are available for the XL™ Light Bar. This section is designed to describe the function of, and maintenance for, the various options.

**Stingray:** The Sting Ray is a modified rotating lamp which produces a patented three-mode signal that (1) oscillates to the rear, (2) rotates conventionally, and (3) oscillates to the front. Lamp and reflector maintenance is the same as for a typical rotating lamp.

**Alley Lights:** Located at each end of the light bar, to provide light to the side of the vehicle. This smaller unit is held in a metal bracket that is attached to the frame with 2 screws.

**High Speed Rotating Lamps:** A rotating lamp that produces twice as many flashes as conventional assembly. The only significant differences between this unit and a normal assembly are that a black worm and worm gear are used. Maintenance is the same as for a typical rotating lamp.

**Stop/Turn/Tail Lights:** Located in the light bar facing rear, one on the passenger side, these lights provide stop, turn, and tail signals to following traffic when connected to the vehicle lighting system. Bulbs used are an 1157 bayonet type.

**D.O.T. Lights:** A set of three marker lights as required by the Department of Transportation for truck application. Bulbs are wedge base '194' type.

**Flasher:** The table below shows the different models and their functions.

<b>FLASHER TYPE</b>					
<b>FEATURES</b>	<b>360RS</b>	<b>360RD</b>	<b>360RDK</b>	<b>700</b>	<b>710/711</b>
100W (2 lights), Alternating Flash	X			X	
200W (4 lights), Alternating flash, rear only or front & rear		X	X		
200W (4 lights), Alternating flash, rear only, front & rear, or steady burn front/rear flash			X		
200W Heavy duty Alternating flash				X	X
200W Heavy duty Programmed flash					X

**NOTES:**

# WARRANTY

This product was tested and found to be operational at the time of manufacture. Provided this product is installed and operated in accordance with the manufacturer's recommendations, Public Safety Equipment guarantees all parts and components except the lamps for a period of 1 year from the date of purchase or delivery, whichever is later. Units demonstrated to be defective within the warranty period will be repaired or replaced at the factory service center at no cost.

Use of a lamp or other electrical load of a wattage higher than installed or recommended by the factory, or use of inappropriate or inadequate wiring or circuit protection causes this warranty to become void. Failure or destruction of the product resulting from abuse or unusual use and/or accidents is not covered by this warranty.

PSE shall in no way be liable for other damages including consequential, indirect or special damages whether loss is due to negligence or breach of warranty.

**PSE MAKES NO OTHER EXPRESS OR IMPLIED WARRANTY INCLUDING, WITHOUT LIMITATION, WARRANTIES OF FITNESS OR MERCHANTABILITY, WITH RESPECT TO THIS PRODUCT.**

# PRODUCT RETURNS

In order to provide you with faster service, if you are going to return a product for repair or replacement\*, please contact our factory to obtain a Return Goods Authorization Number (RGA number) before you ship the product to PSE. Write the RGA number clearly on the package near the mailing label. Be sure you use sufficient packing materials to avoid damage to the product being returned while in transit.

\*PSE reserves the right to repair or replace product at its discretion. PSE assumes no responsibility or liability for expenses incurred for the removal and/or reinstallation of products requiring service and/or repair.

Code 3, Inc.  
10986 N. Warson Road  
St. Louis, Missouri 63114-2029—USA  
Ph. (314) 426-2700 Fax (314) 426-1337  
[www.code3pse.com](http://www.code3pse.com)